



# SERVICE PARTS LIST

BULLETIN NO.  
54-04-1825

SPECIFY CATALOG NO. AND SERIAL NO. WHEN ORDERING PARTS			REVISED BULLETIN
<b>6 Bay M18 Battery Charger</b>			
CATALOG NO.	48-59-1806	SERIAL NUMBER	E50A
			WIRING INSTRUCTION

**EXAMPLE:**

00	0
----	---

Component Parts (Small #)  
Are Included When Ordering  
The Assembly (Large #).

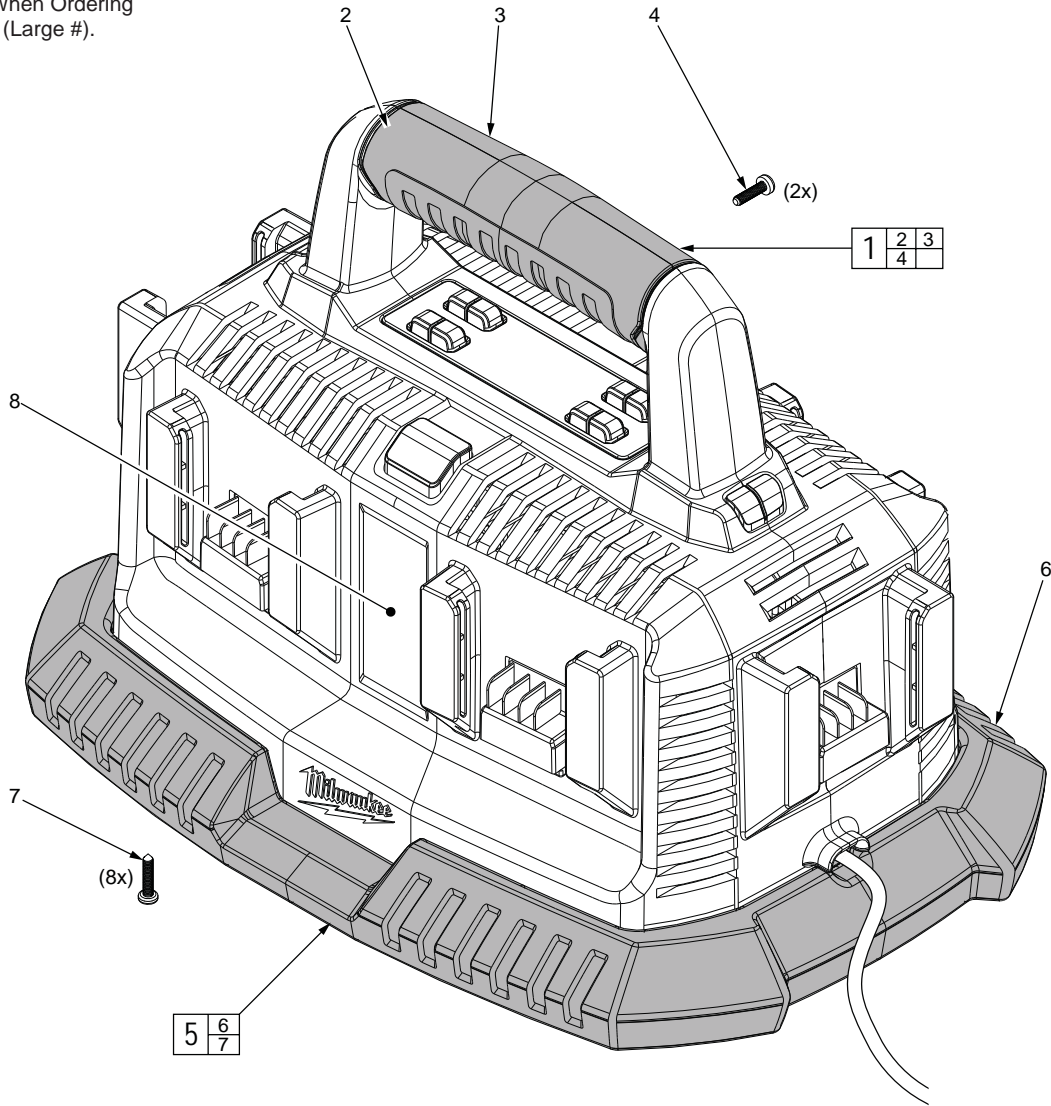

FIG.	PART NO.	DESCRIPTION OF PART	NO. REQ.
1	31-44-2730	Handle Grip Kit	(1)
2	-----	Front Grip Halve	(1)
3	-----	Rear Grip Halve	(1)
4	-----	Screw - For Grip	(2)
5	31-06-0250	Base Kit	(1)
6	-----	Base	(1)
7	-----	Screw - For Base	(8)
8	12-20-1806	Service Nameplate	(1)
9	10-20-1806	Warning Label (Not Shown)	(1)

**FIG. NOTES**

8,9 A clean, dry surface is essential for proper performance for any adhesive system. The area intended for application of any adhesive label or nameplate must be prepared by cleaning with isopropyl alcohol. The solvent is to be applied with a clean, lint free applicator and the surface allowed to dry before applying the label or nameplate.