



SERVICE PARTS

BULLETIN NO.
54-49-8400

SPECIFY CATALOG NO. AND SERIAL NO. WHEN ORDERING PARTS		REVISED BULLETIN	DATE
PACKOUT™ Rolling Tool Box Assembly			Feb. 2020
CATALOG NO. 48-22-8426	SERIAL NUMBER	WIRING INSTRUCTION	

48-22-8426 Includes:

48-22-8425	PACKOUT™ Large Tool Box Assembly	Page 3
48-22-8424	PACKOUT™ Medium Tool Box Assembly	Page 3
48-22-8430	PACKOUT™ Organizer Assembly	Page 4
48-22-8435	PACKOUT™ Compact Organizer Assembly	Page 4
48-22-8310	PACKOUT™ Small 10" Storage Tote	Page 5
48-22-8315	PACKOUT™ Medium 15" Storage Tote	Page 5
48-22-8320	PACKOUT™ Large 20" Storage Tote	Page 5

EXAMPLE:
Component Parts (Small #) Are Included When Ordering The Assembly (Large #).

FIG.	PART NO.	DESCRIPTION OF PART	NO. REQ.
1	43-62-8400T	Retractable Handle Grip Service Kit	(1)
2	-----	Screw	(2)
3	43-62-8400	Retractable Handle Service Assembly	(1)
4	-----	Screw	(2)
5	43-62-8426	Side Handle Service Kit (Contains 2 Side Handles and 4 Pins)	(1)
6	-----	Pin	(4)
7	45-94-8426	Wheel Service Kit (Contains 2 Wheels and 2 Locking Hex Nuts)	(1)
8	-----	Locking Hex Nut	(2)
9	44-20-8400	Latch Service Assembly (Set of 2)	(1)
10	31-01-8400	Storage Tray	(1)
11	43-44-8400	Lid Gasket (Not Shown)	(1)
12	42-12-8426	Axle Service Kit (Contains 1 Axle and 2 Locking Hex Nuts)	(1)

***See page 6 thru 11 for Additional Storage Products:**

48-22-8431	PACKOUT™ S-Organizer Assembly	Page 6
48-22-8436	PACKOUT™ S-Organizer Compact Assembly	Page 6
48-22-8450	PACKOUT™ Tool Box Assembly	Page 7
48-22-8321	PACKOUT™ Medium 15" Tool Bag	Page 8
48-22-8322	PACKOUT™ Large 20" Tool Bag	Page 8
48-22-8300	PACKOUT™ Tech Bag	Page 9
48-22-8301	PACKOUT™ Jobsite Backpack	Page 9
48-22-8302	PACKOUT™ Jobsite Cooler	Page 9
48-22-8410	PACKOUT™ Flat Dolly	Page 10
48-22-8422	PACKOUT™ Compact Toolbox	Page 11
48-22-8460	PACKOUT™ Compact Cooler	Page 11

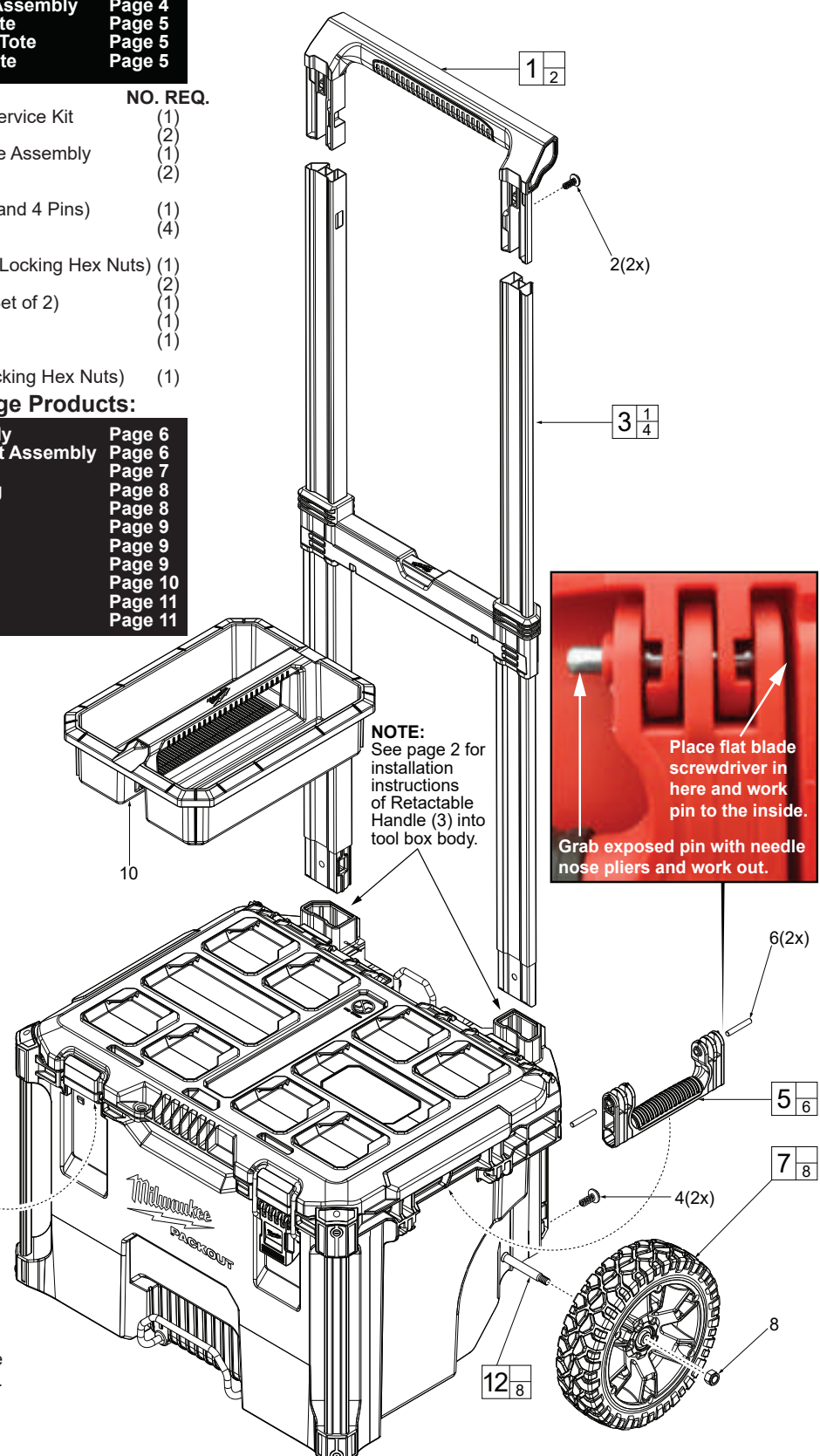

As an aid to removing a damaged Latch Assembly (9), use two large flat blade screwdrivers. Push blades between parts as shown. Twist both screwdrivers at same time to force the blades into opening and work the latch assembly over the two locking tabs.

To install a new latch assembly, position entire latch assembly over locking tabs with the two top lugs partially inserted in 'catch cavity' of main housing. Engage latch bar onto lid and gently press latch lever to slide assembly over two locking tabs and into place.

This removal and installation process will be the same where other service latches are offered in this system.

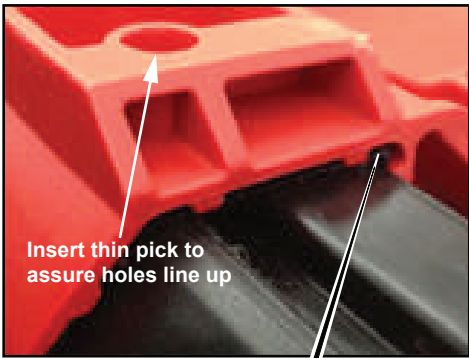

As an aid to installation, collapse the Retractable Handle Assembly (3).

Properly orient the assembly and insert both sides into tool box channels.

Holes of Retractable Handle Assembly (3) must line up with holes on the back of tool box body prior to securing with screws (4).

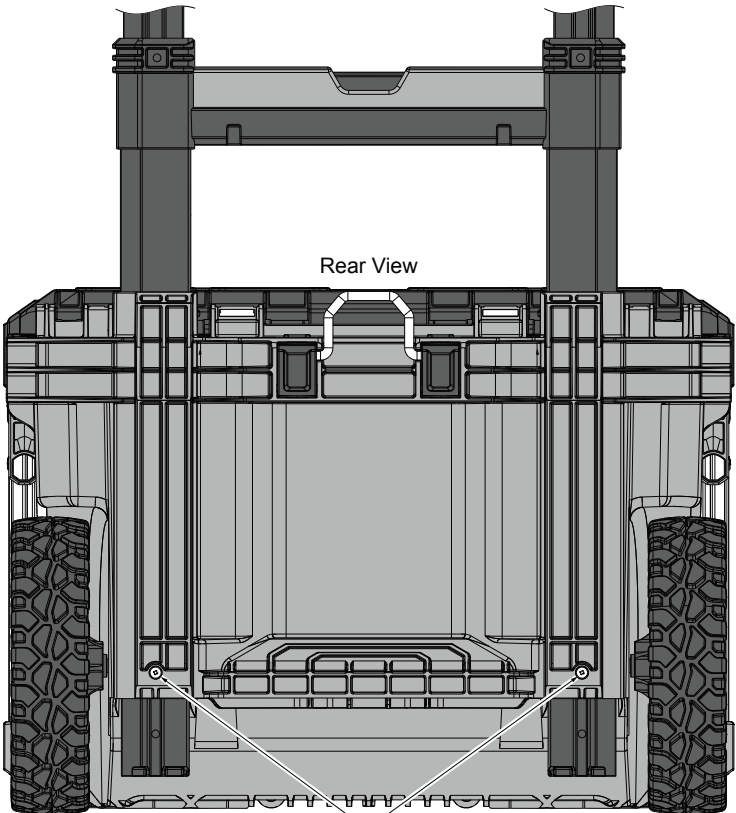

48-22-8425 PACKOUT™ (Large) Tool Box

FIG.	PART NO.	DESCRIPTION OF PART	NO. REQ.
1	43-62-8425	Top Handle Service Kit	(1)
2	-----	Pin	(2)
3	43-62-8424	Side Handle Service Kit	(1)
4	-----	Pin	(2)
5	44-20-8400	Latch Service Assembly (Set of 2)	(1)
6	31-01-8400	Storage Tray	(1)
7	43-44-8400	Lid Gasket (Not Shown)	(1)

Pins to be installed from the inside of the handle.

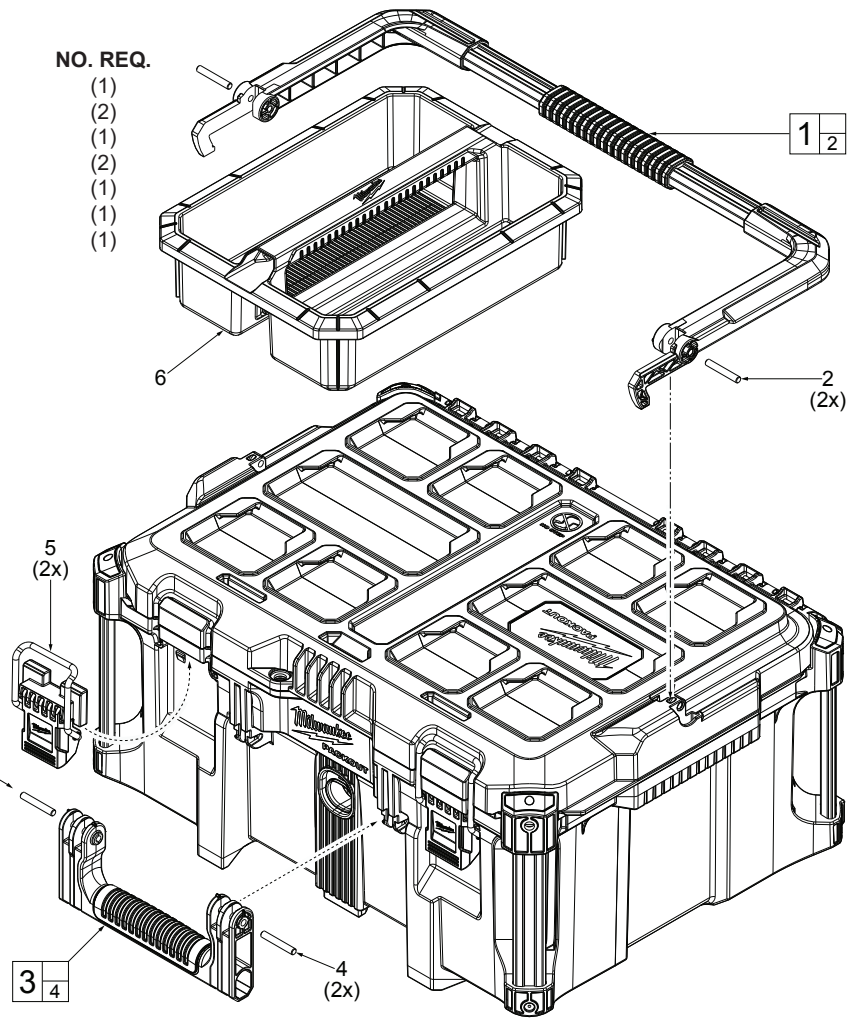

48-22-8424 PACKOUT™ (Medium) Tool Box

FIG.	PART NO.	DESCRIPTION OF PART	NO. REQ.
3	43-62-8424	Side Handle Service Kit	(1)
4	-----	Pin	(2)
5	44-20-8400	Latch Service Assembly (Set of 2)	(1)
7	43-44-8400	Lid Gasket (Not Shown)	(1)
8	31-01-8424	Storage Bin Kit (Set of 4)	(1)
8a	-----	Deep Bin with Two Dividers	(2)
8b	-----	Shallow Bin	(1)
8c	-----	Shallow Bin with Cover	(1)

Pins to be installed from the inside of the handle.

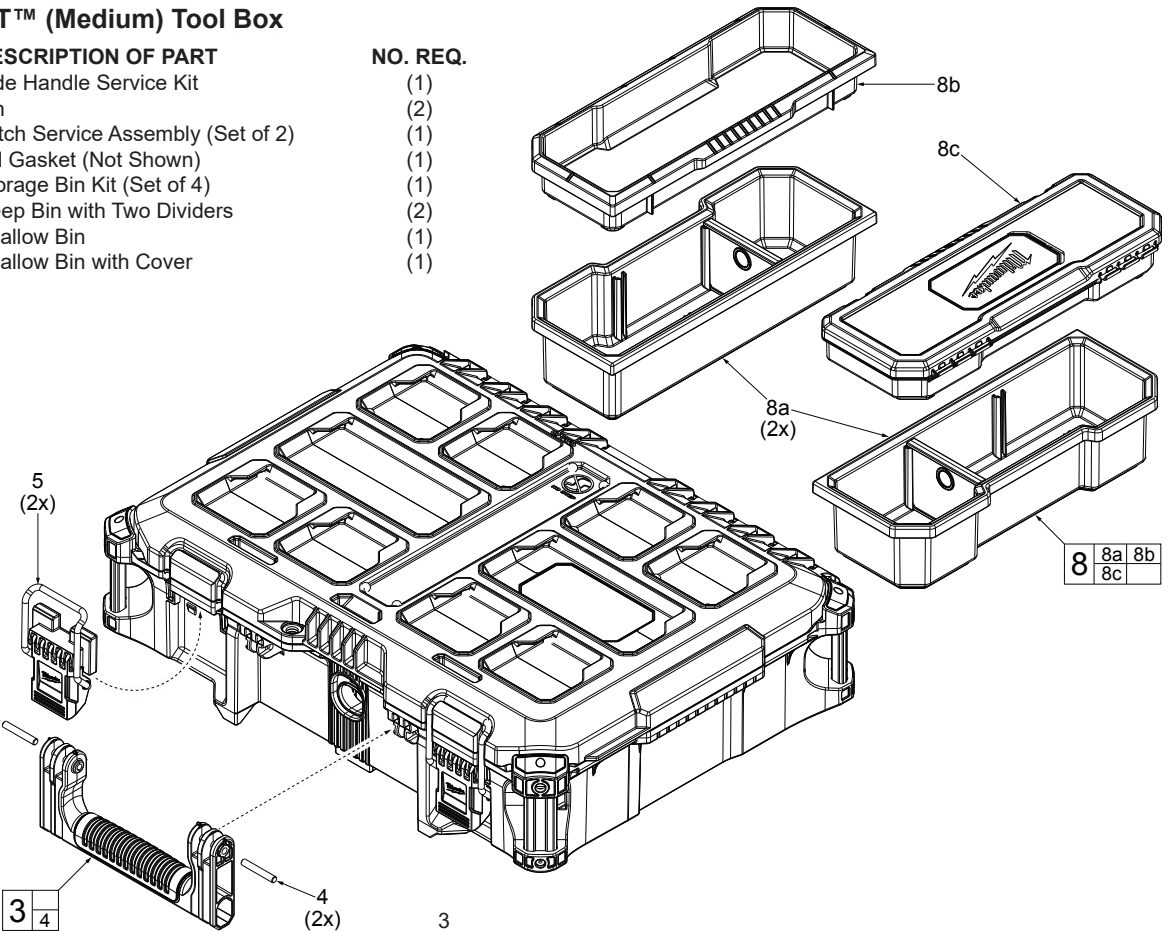

48-22-8430 PACKOUT™ Organizer

FIG.	PART NO.	DESCRIPTION OF PART	NO. REQ.
3	43-62-8430	Side Handle Service Kit	(1)
4	-----	Pin	(2)
5	44-20-8430	Latch Service Assembly (Set of 2)	(1)
7	43-44-8430	Lid Gasket (Not Shown)	(1)
9	31-01-0501	5 Bin Kit (Set of 1)	(2)
9a	-----	Large Bin	(1)
9b	-----	Small Bin	(4)

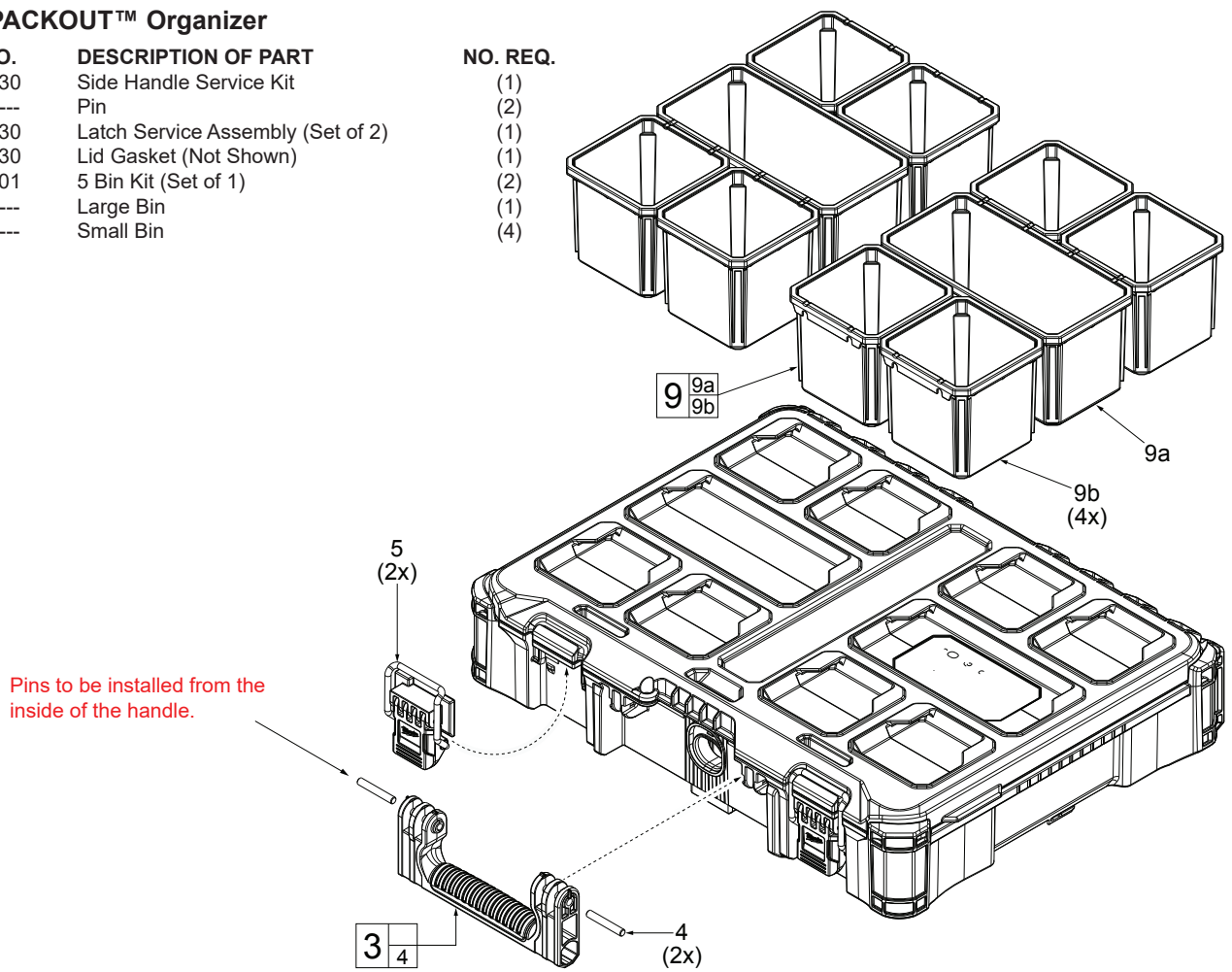

48-22-8435 PACKOUT™ Compact Organizer

FIG.	PART NO.	DESCRIPTION OF PART	NO. REQ.
3	43-62-8435	Side Handle Service Kit	(1)
4	-----	Pin	(2)
7	43-44-8435	Lid Gasket (Not Shown)	(1)
9	31-01-0501	5 Bin Kit	(1)
9a	-----	Large Bin	(1)
9b	-----	Small Bin	(4)

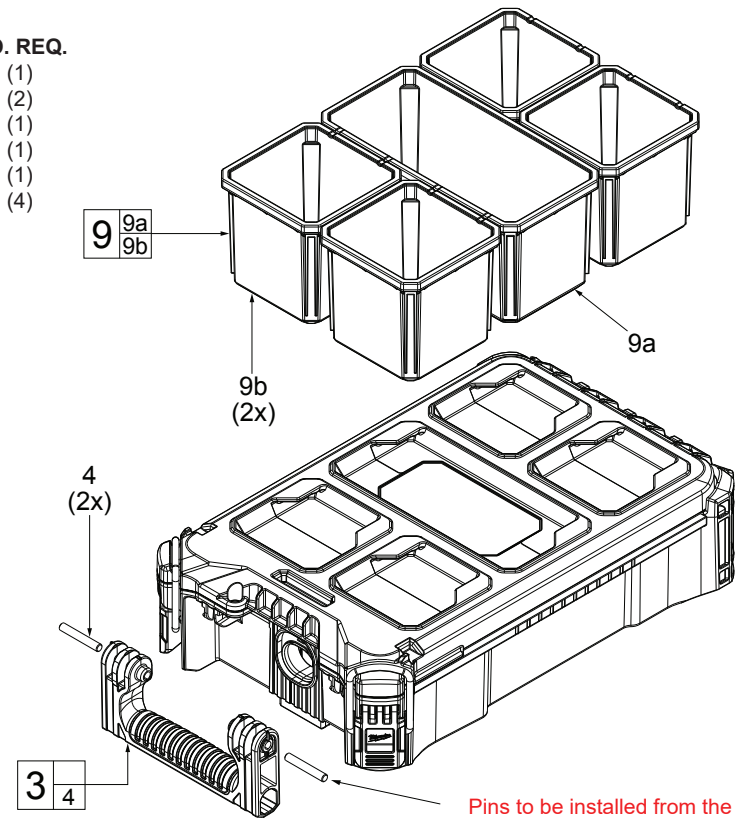

- 48-22-8310 10" PACKOUT™(Small) Storage Tote
- 48-22-8315 15" PACKOUT™ (Medium) Storage Tote
- 48-22-8320 20" PACKOUT™ (Large) Storage Tote



FIG.	PART NO.	DESCRIPTION OF PART	NO. REQ.
1	45-56-8300	Shoulder Strap (For all three tote models)	(1)
2	44-20-8300	Locker Kit (For all three tote models)	(1)
	or		
3	44-20-0305	Locker Kit (For all three tote models)	(1)



SEE DIAGRAMS BELOW TO DETERMINE LOCKER SERVICE PART NEEDED.



To remove a damaged locker system, flip tote upside down and approach tote from the bottom of base. Insert a large flat blade screwdriver in middle of locking carriage as shown. Lightly pry carriage upward out of base opening. Remove and discard old locking carriage and spring.

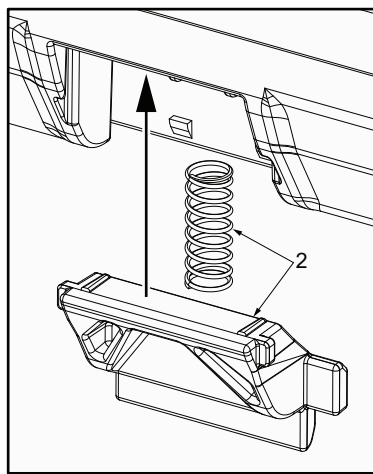

No. 44-20-8300
Locker Kit
For early production PACKOUT™ Storage Totes

To install a Locker Kit (2), align spring as shown and guide the tabs of locking carriage in channels of tote base. Push locking carriage upward to snap into place.



To remove a damaged locker system, flip tote over on the side and approach tote from the bottom of base. Insert a large flat blade screwdriver in middle of locking carriage as shown. Lightly pry carriage upward out of base opening. Remove and discard old locking carriage.

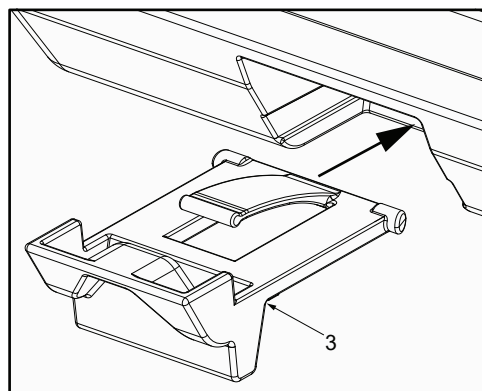

No. 44-20-0305
Locker
For later production PACKOUT™ Storage Totes

To install a new Locker (3), guide the tabs of locking carriage in channels of tote base. Push locking carriage forward to snap into place.

48-22-8431 PACKOUT™ S-Organizer Assembly

FIG.	PART NO.	DESCRIPTION OF PART	NO. REQ.
1	44-20-8431	LP Organizer Latch (Set of 2)	(1)
2	31-01-0502	5 PC Bin S-Organizer with 6 Dividers	(2)
3	43-44-8430	Lid Gasket (Not Shown)	(1)
4	31-01-0503	Spare Divider Kit, 6 pcs.	(0)

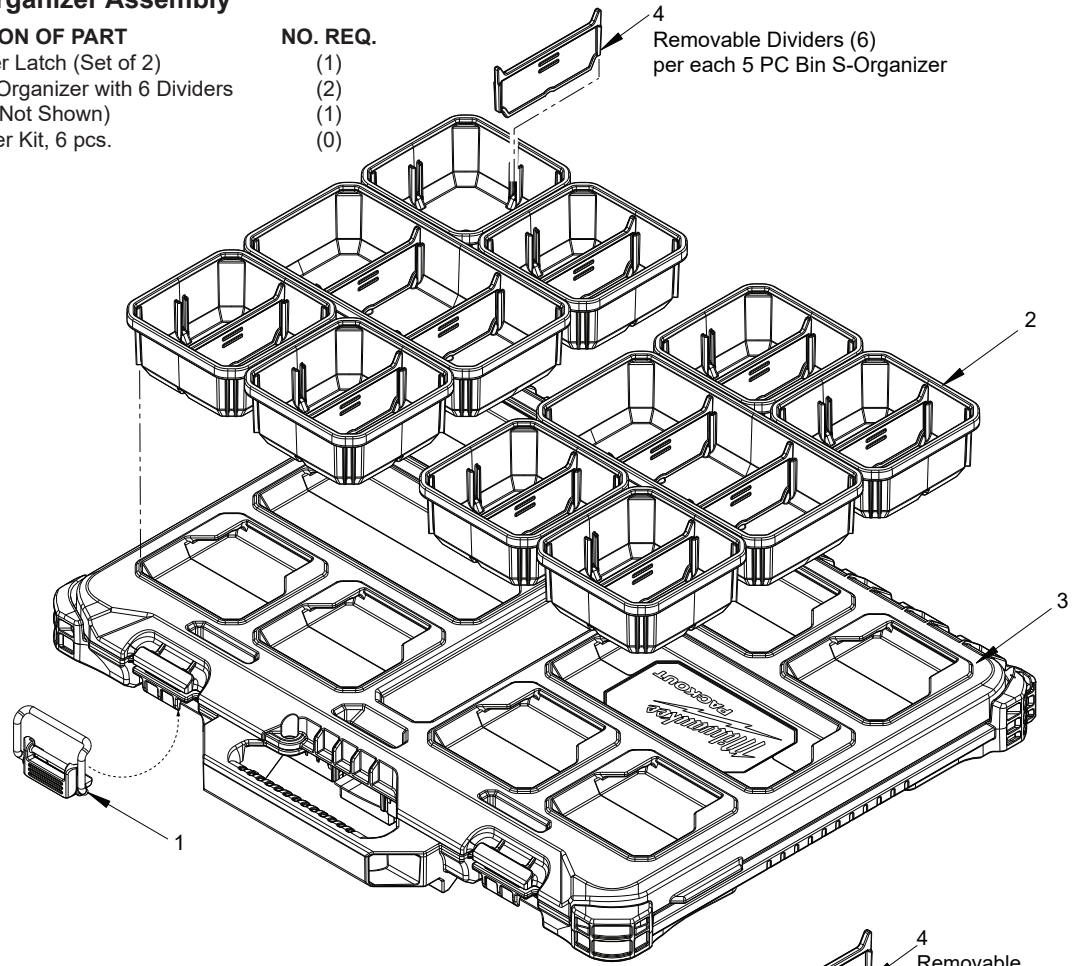

48-22-8436 PACKOUT™ S-Organizer Compact Assembly

FIG.	PART NO.	DESCRIPTION OF PART	NO. REQ.
1	44-20-8436	LP Compact Org Latch (Set of 2)	(1)
2	31-01-0502	5 PC Bin S-Organizer with 6 Dividers	(1)
3	43-44-8435	Lid Gasket (Not Shown)	(1)
4	31-01-0503	Spare Divider Kit, 6 pcs.	(0)

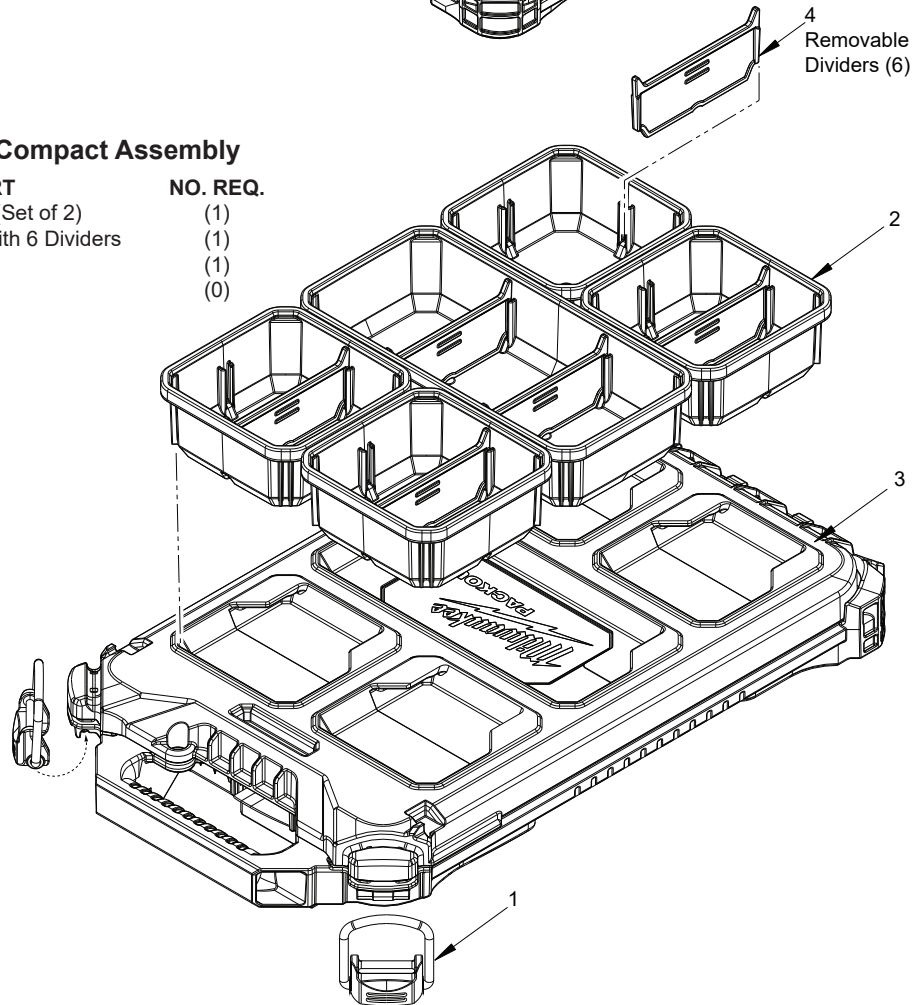

48-22-8450 PACKOUT™ Tool Box Kit with Foam Dividers

FIG.	PART NO.	DESCRIPTION OF PART	NO. REQ.
1	43-62-8450	Kit Box Mono Block Handle with 2 Pins	(1)
2	44-20-8430	Latch Service Assembly (Set of 2)	(2)
3	43-44-8400	Lid Gasket (Not Shown)	(1)
4	48-22-8455	Foam Insert for PACKOUT™ Kit Box (Set of 2)	(1)

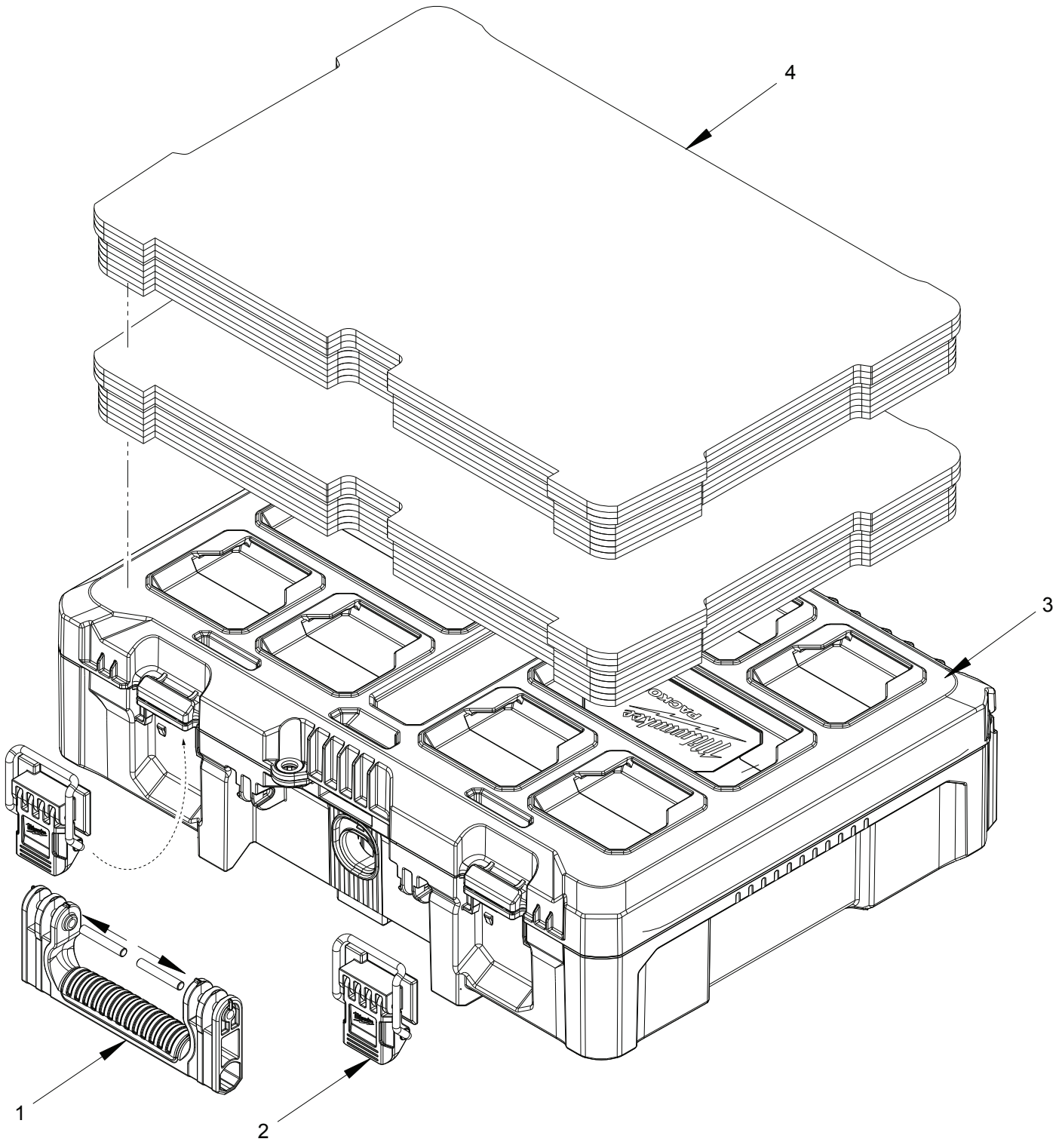

48-22-8321 15" PACKOUT™ (Medium) Tool Bag*

SPECIAL NOTE: There are two locker designs for the 15" model. An early version of the 48-22-8321 had a different locker system. The design used in the 20" model was incorporated in later production of the 15" model. See page two.



Locker located on side

48-22-8322 20" PACKOUT™ (Large) Tool Bag*



Locker located in front

***48-22-8321 15" PACKOUT™ (Medium) Tool Bag**

***48-22-8322 20" PACKOUT™ (Large) Tool Bag**

FIG.	PART NO.	DESCRIPTION OF PART	NO. REQ.
1	45-56-8300	Shoulder Strap (For both tote models)	(1)
2	44-20-8300	Locker Kit (For early versions of 48-22-8321) See page two	(1)
3	44-20-0305	Locker (For 48-22-8322 and later versions of 48-22-8321) See page 5	(1)

SEE PAGE 5 FOR INSTRUCTIONS ON REMOVING SELECTION AND INSTALLING BOTH LOCKER SYSTEMS



48-22-8300 PACKOUT™ Tech Bag



48-22-8301 PACKOUT™ Jobsite Backpack



48-22-8302 PACKOUT™ Jobsite Cooler



FIG.	PART NO.	DESCRIPTION OF PART	NO. REQ.
1	45-56-8300	Shoulder Strap (For Cooler & Tech Bag)	(1)
2	44-20-0305	Locker System	(1)

SEE PAGE 5 FOR INSTRUCTIONS ON REMOVING AND INSTALLING BOTH LOCKER SYSTEMS



48-22-8410 PACKOUT™ Flat Dolly

Locking Casters (1) are to be assembled to the front of the PACKOUT™ Dolly Body (3). Front of the dolly body is determined by the logo plate.

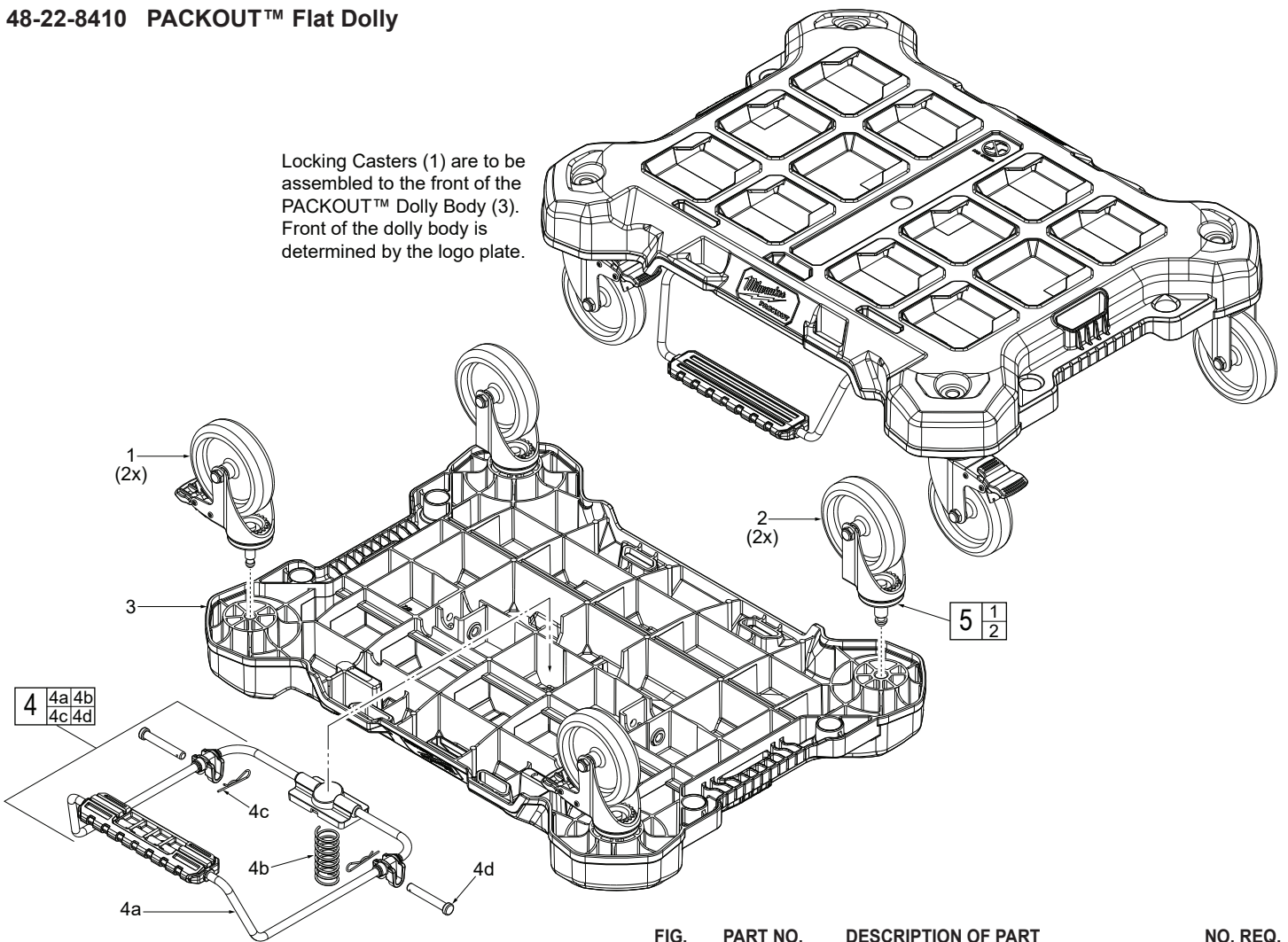
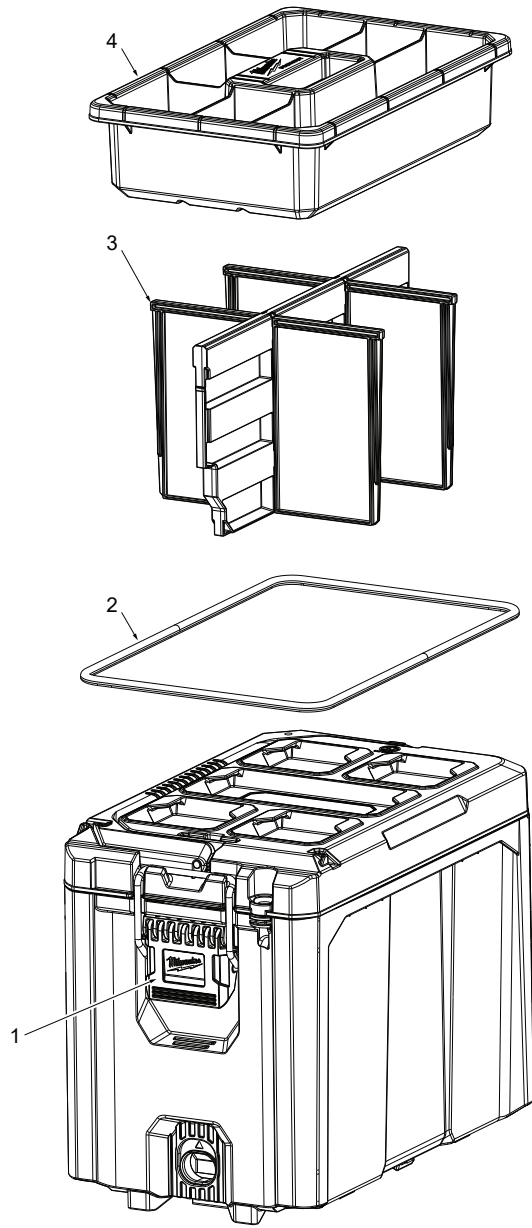
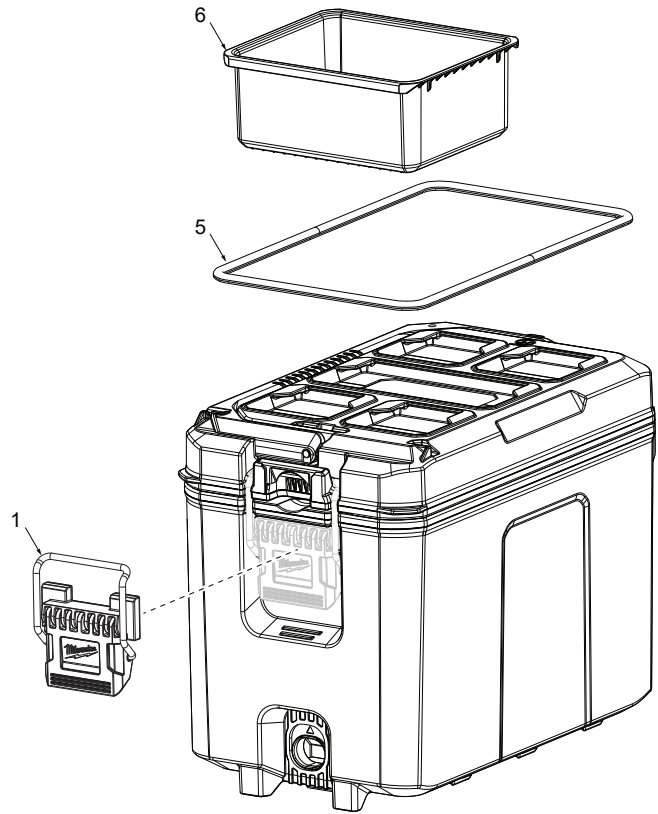

FIG.	PART NO.	DESCRIPTION OF PART	NO. REQ.
1	-----	Locking Swivel Caster	(2)
2	-----	Swivel Caster	(2)
3	-----	Dolly Base	(1)
4	14-04-8410	Dolly Foot Brake Kit	(1)
4a	-----	Dolly Foot Brake	(1)
4b	-----	Spring	(1)
4c	-----	Cotter Pin	(2)
4d	-----	Retaining Pin	(2)
5	45-94-8410	Swivel Caster Kit (Set of 4)	(1)



Note: Tray, Dividers and Gasket illustrated outside of PACKOUT, is to be assembled on the inside.



Note:
Procedure for removal and installation of the 44-20-8422 Latch (1).

- Removal:**
1. Undo latch from PACKOUT lid.
 2. Insert a flathead screwdriver in-between latch assembly and PACKOUT base to pry over the tabs. (Fig.1)
 3. Pull metal latch down to remove.

- Installation:**
1. Insert Latch Assembly into channel.
 2. Attach the metal latch to the lid. (Fig.2)
 3. Close latch to secure Latch Assembly in place inside the channel.

Fig.1

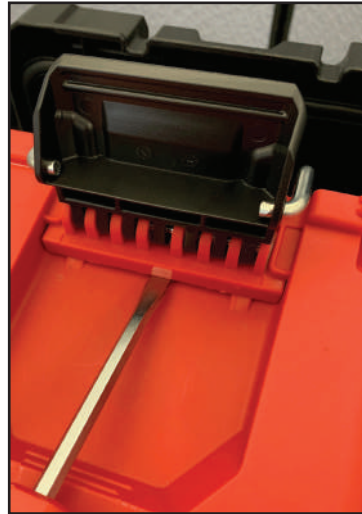

Fig. 2



48-22-8422 PACKOUT™ Compact Toolbox

FIG.	PART NO.	DESCRIPTION OF PART	NO. REQ.
1	44-20-8422	Latch Assembly	(1)
2	43-44-8422	Gasket	(1)
3	31-01-8423	Dividers	(1)
4	31-01-8422	Tray	(1)

48-22-8460 PACKOUT™ Compact Cooler

FIG.	PART NO.	DESCRIPTION OF PART	NO. REQ.
1	44-20-8422	Latch Assembly	(1)
5	31-01-8460	Tray	(1)
6	43-44-8460	Gasket	(1)