

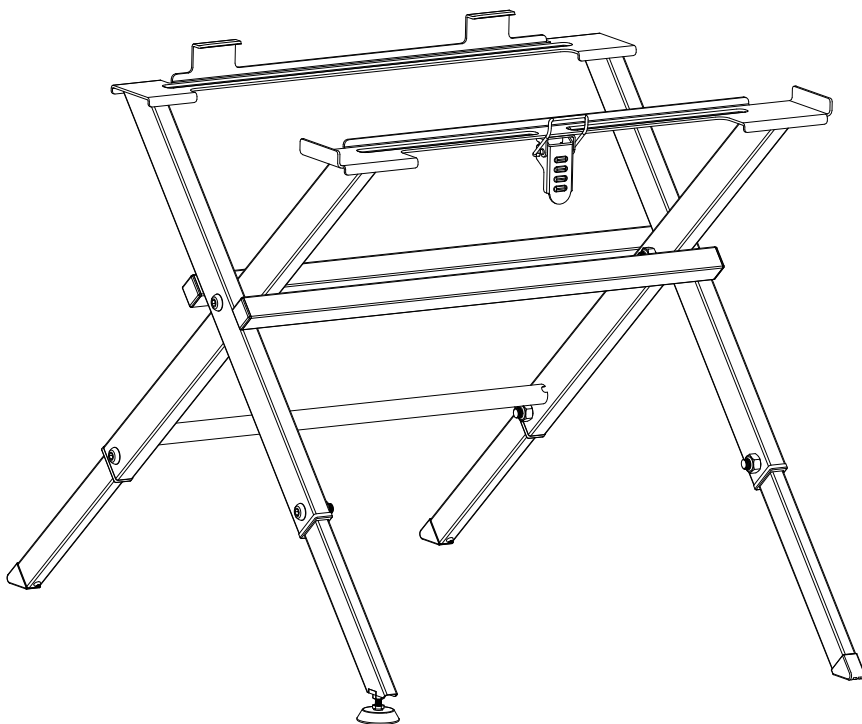

OPERATOR'S MANUAL



Cat. No.
48-08-0561

FOLDING TABLE SAW STAND



WARNING To reduce the risk of injury, user must read and understand operator's manual.

SPECIFIC SAFETY RULES TABLE SAW STAND

WARNING Read all safety warnings and all instructions provided with the table saw stand and the table saw to be mounted. Failure to follow the warnings and instructions may result in electric shock, fire and/or serious injury. Save all warnings and instructions for future reference.

- **Disconnect the battery pack from the table saw before making any adjustments or changing accessories.** Accidental starting of the power tool is a cause of some accidents.
- **Properly assemble the table saw stand before mounting the tool.** Proper assembly is important to prevent risk of collapse.
- **Securely fasten the table saw to the table saw stand before use.** Table saw shifting on the table saw stand can cause loss of control.
- **Place the table saw stand on a solid, flat and level surface.** If the table saw stand can shift or rock, the table saw or workpiece cannot be safely controlled.
- **Do not overload the table saw stand or use as ladder or scaffolding.** Overloading or standing on the table saw stand causes the stand to be “top-heavy” and likely to tip over.
- **Use only with MILWAUKEE Table Saws 2736-20, and mount securely, according to these instructions.** Improperly installed Table Saws can cause injury or property damage.
- **Avoid dangerous environments.** Use your tool stand on flat, level, dry, and hard surfaces only.
- **Keep work area clean and well lit.** Cluttered, dark work areas invite accidents.
- **The table saw stand weight limit is 180 lb (82 kg).** If more than 180 lbs is placed on the table saw stand it may be damaged and may cause personal injury.
- **Maintain control.** Keep proper footing and balance at all times.
- **Maintain table saw stand carefully.** Keep table saw stand dry, clean and free from oil and grease. Follow instructions for changing accessories. Periodically inspect table saw stand for damage and wear.
- **Maintain labels.** These carry important information. If unreadable or missing, contact a MILWAUKEE service facility for a free replacement.
- **Keep bystanders away.** Children and bystanders should be kept at a safe distance from the work area to avoid distracting the operator.
- **To reduce the risk of injury, always wear eye protection.**
- **Fingers can be pinched between the legs of the table saw stand. To reduce the risk of injury, keep your fingers out of the areas where the legs will fold.**
- **Always use common sense and be cautious when using tools.** It is not possible to anticipate every situation that could result in a dangerous outcome. Do not use this tool if you do not understand these operating instructions or you feel the work is beyond your capability; contact Milwaukee Tool or a trained professional for additional information or training.

ASSEMBLY

WARNING Properly assemble the table saw stand before mounting the tool. Proper assembly is important to ensure stability. Legs must match with corresponding number indicators on the stand.

Assembling the Stand

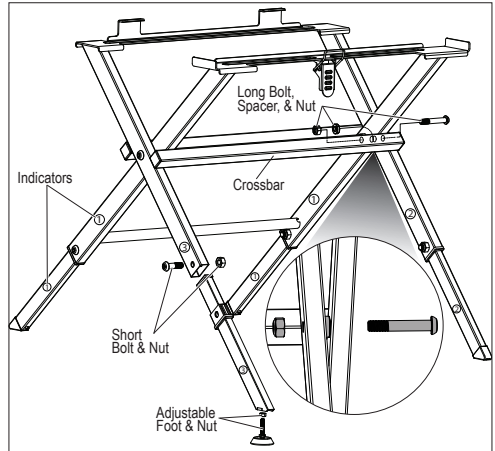

1. Remove all packaging and zip ties.
2. Insert the legs into the frame according to the indicator stickers. Mismatched leg/frame assembly will cause the frame to wobble.
3. Insert a small bolt through the frame/legs assembly and thread on the nut. Use a 6 mm hex wrench and an adjustable (or 17 mm open end) wrench to securely tighten.
4. Insert the legs of narrower frame through the opening between the cross bar and top of the wider frame. To complete this step and align the bolt holes, you will need to tip the narrow frame side to side to pass the cross bar through the opening of the wider frame.
5. Lay the assembly on its side and align the bolt holes, placing the plastic spacer between the frame sections, as shown.
6. Insert the long bolt through the wider frame, spacer, and narrower frame and secure with the nut. Use a 6 mm hex wrench and an adjustable (or 17 mm open end) wrench to securely tighten.
7. Screw the nut onto the adjustable foot (the nut may come factory assembled)
8. Screw in the adjustable foot into the stand until the stand sits level. Turn the nut back until it contacts the frame, locking the adjustable foot in place.

Installing the Table Saw

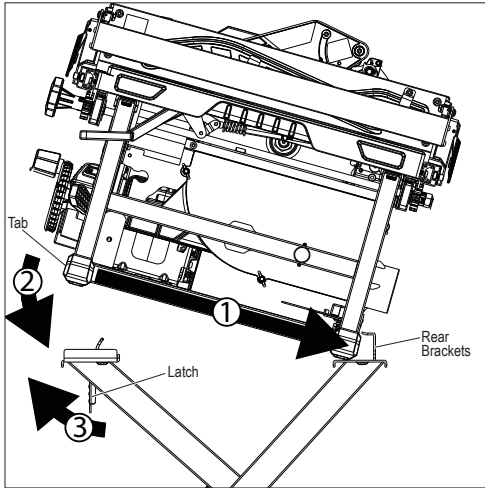

1. Hook the back of the saw into the rear brackets.
2. Lower the front of the saw onto the frame.
3. Secure the latch onto the saw's front tab.

⚠WARNING Properly level the table saw stand before each use. If the table saw stand can shift or rock, the table saw or workpiece cannot be safely controlled.

Leveling

1. Loosen the locking nut.
2. Screw in or out the foot to level the stand.
3. Tighten the locking nut flush with stand.