

WIRING INSTRUCTIONS

TITLE

1/2" POWER PACK DRILL MOTOR

BULLETIN
58-01-0402

DATE
Dec. 2009

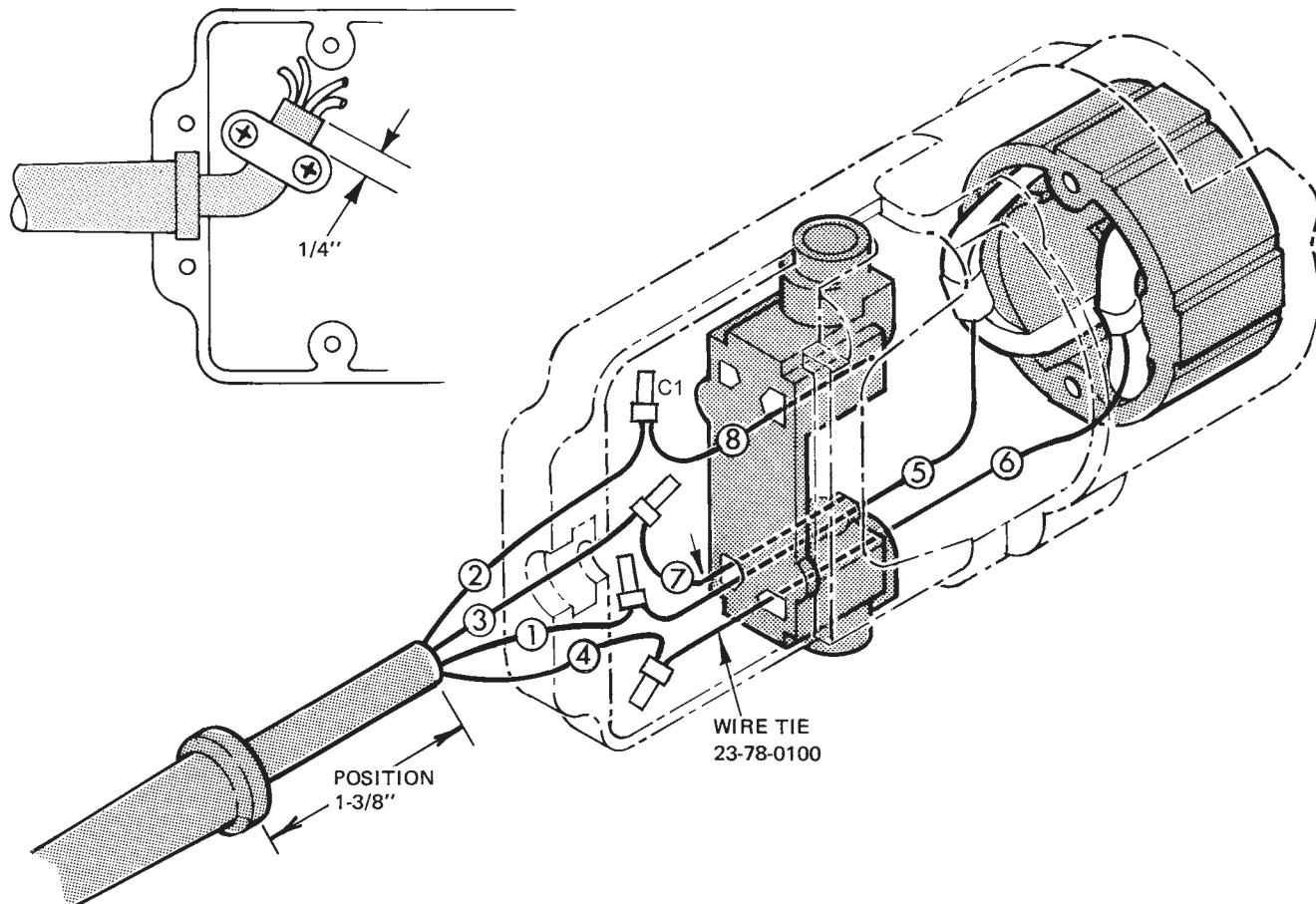

NOTE:

All lead lengths are before stripping.
All field leads are to be measured from and perpendicular to laminations.
All leads must be held to $\pm 1/8$ ".

WIRING SPECIFICATIONS

Wire No.	Wire Color	Origin or Part No.	Gauge	Length	Terminals, Connectors and End Wire Preparation
1	White	Cord	--	3-3/4"	Strip 1/2" for C1
2	Red	Cord	--	3-3/4"	Strip 1/2" for C1
3	Blue	Cord	--	3-3/4"	Strip 1/2" for C1
4	Black	Cord	--	3-3/4"	Strip 1/2" for C1
5	Black	Field	--	6"	Strip 1/2" for C1
6	Red	Field	--	6"	Strip 1/2" for C1
7	Black	23-94-4581	18	5"	Strip 3/8" for T1 / Strip 1/2" for C1
8	Yellow	23-94-4583	18	5"	Strip 3/8" for T1 / Strip 1/2" for C1

BULK LEAD WIRE - BULLETIN 58-01-0003

TERMINAL DESCRIPTION

Code	Part No.	Qty.
T1	22-44-0090	2

CONNECTOR DESCRIPTION

Code	Part No.	Qty.
C1	22-56-0160	4

Drwg. 3