

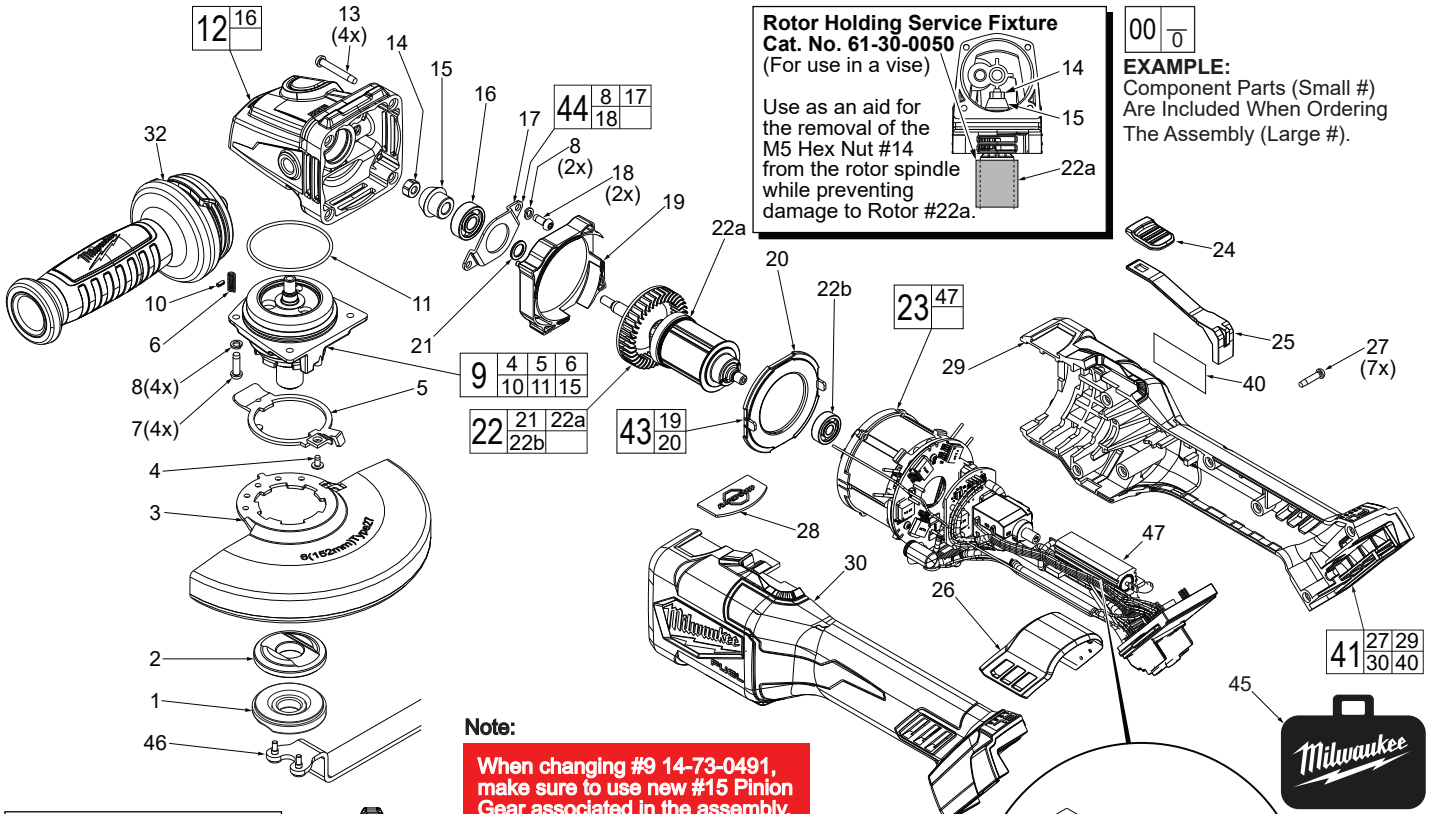

SERVICE PARTS LIST

BULLETIN NO.
54-38-2910

SPECIFY CATALOG NO. AND SERIAL NO. WHEN ORDERING PARTS		REVISED BULLETIN	DATE
M18 FUEL™ HP Grinder w/ Slide Switch			Aug. 2019
CATALOG NO. 2981-20	STARTING SERIAL NO. K03A	WIRING INSTRUCTION SEE PAGE 2	



***LUBRICATION NOTE:**
When servicing the Gear Case Assembly, 90-95% of the old grease must be removed prior to new grease being added.

FIG. 9,15 LUBRICATION*
Type "Y" Grease, No. 49-08-5270, Must Be Applied To All Gear Teeth.

12 Place 19g ± 0.5 (approx. 5/8 oz) of "Y" grease in gear cavity of gearcase.

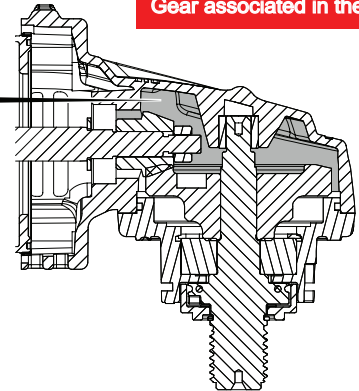

Note:
When changing #9 14-73-0491, make sure to use new #15 Pinion Gear associated in the assembly.

FIG.	PART NO.	DESCRIPTION OF PART	NO. REQ.
1	05-59-0016	5/8"-11 Fixtec Nut	1
2	43-34-0937	Flange Disc	1
3	43-54-1240	6" Type 27 Guard Assembly	1
4	05-81-0020	M3 x 5mm Pan Hd. T-8 Screw	1
5	44-20-0155	Guard Locking Tang	1
6	-----	Spring	1
7	05-78-5316	M4 x 14mm Pan Hd. Tapt. T-20 Screw	4
8	05-90-0225	Spring Washer	6
9	14-73-0491	5/8"-11 Spindle Hub Assembly	1
10	-----	Steel Pin	1
11	34-40-0180	O-Ring	1
12	14-30-0162	Gearcase Assembly	1
13	05-88-1300	M4 x 28mm Pan Hd. ST T-20 Screw	4
14	05-55-0620	M5 Hex Nut	1
15	-----	Pinion Gear	1
16	02-04-0621	Ball Bearing	1
17	44-66-0450	Bearing Retainer	1
18	05-78-0105	M4 x 10mm Pan Hd. T-20 Screw	2
19	-----	Fan Baffle	1
20	-----	Fan Baffle Foot	1

FIG.	PART NO.	DESCRIPTION OF PART	NO. REQ.
21	45-88-0406	Washer	1
22	16-07-2980	Rotor Assembly	1
22a	-----	Rotor	1
22b	02-04-0034	Ball Bearing	1
23	14-20-2981	Electronics Assembly Consisting of: Stator, Switch, PCBA and Battery Terminal Connector Block	1
24	31-89-2981	Slide Pole Button	1
25	31-84-2981	Slide Pole	1
26	31-15-0277	Dust Cover	1
27	06-82-2025	M3.5 x 16mm Pan Hd. ST T-10 Screw	7
28	43-84-0207	Rapid Stop Plate	1
29	-----	Right Housing Halve - Cover	1
30	-----	Left Housing Halve - Support	1
32	42-62-0125	Side Handle Assembly	1
40	12-20-0139	Service Nameplate	1
41	31-44-2981	Housing Kit	1
43	42-14-0040	Baffle Assembly	1
44	44-86-0195	Bearing Retaining Plate Assembly	1
45	50-55-3560	Medium FUEL Contractor Bag	1
46	49-96-0014	Spanner Wrench	1
47	23-38-0065	Resistor Assembly	1

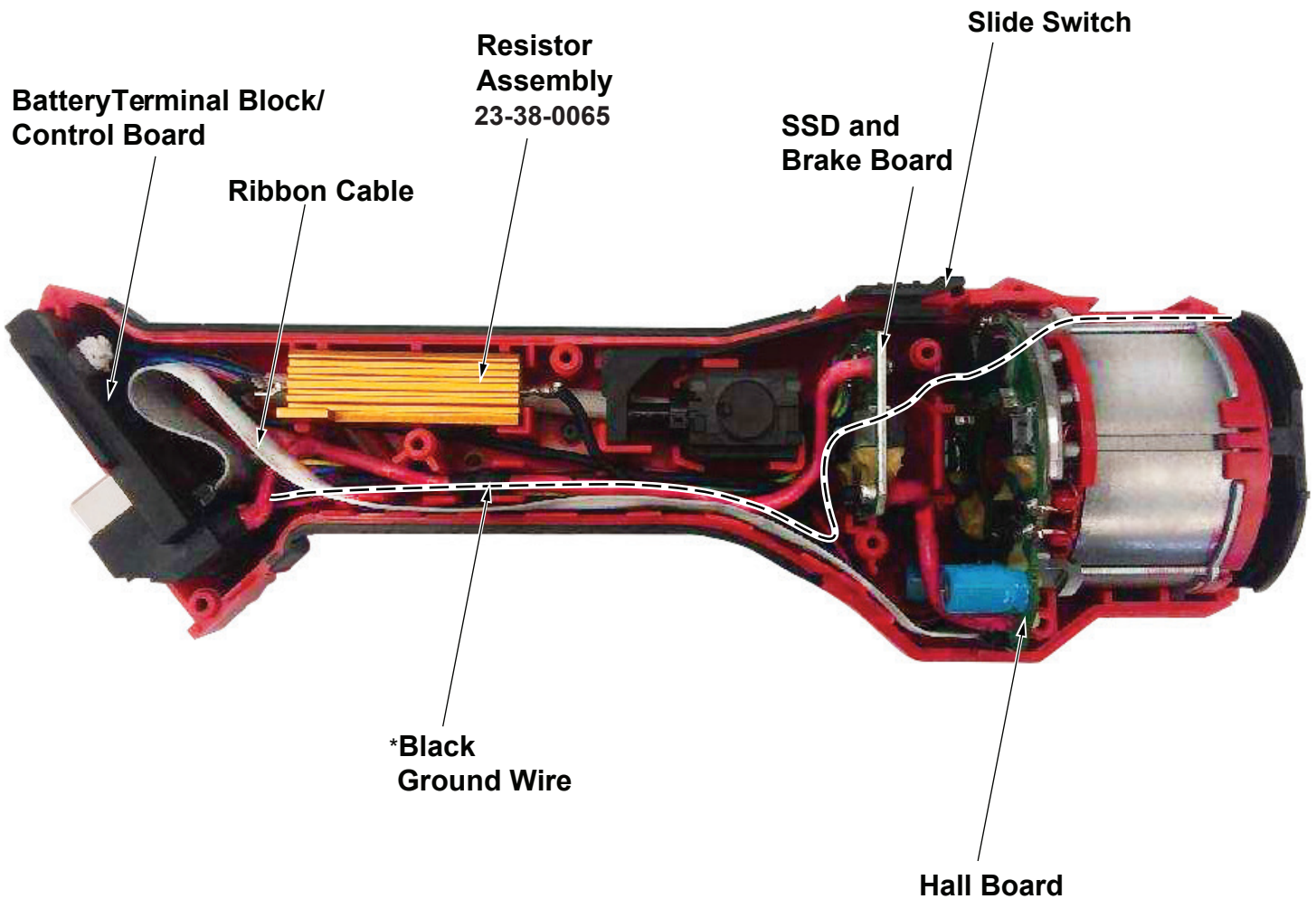

*The Black Ground Wire demonstrated in above diagram is placed toward bottom and in the back of all other wires and components assembled in the main housing.

M18 FUEL™ HP Grinder w/Slide Switch Catalog Number: 2981-20

NOTE: Prior to installing a new Electronics Assembly (23), the front gearcase assembly (12) must be removed. Pay very close attention to the wire routing and wire placement in traps and channels in the left housing half-support (30). As an aid, it is recommended that a cell phone photograph be taken of the unit with the right housing half-cover (29) removed for reference. The electronics assembly is offered as one entire unit (several major components joined together by wires and a ribbon cable) and must be carefully installed into the left housing half.

*The voltage protection ground wire must be installed before the electronics assembly is placed into the left housing half-support. Place the wavy ring terminal over the top screw boss in front of left housing half. Route the wire through the wire traps, pushing the wire to the bottom as you go along.

Try to route wires and ribbon cable in traps as illustrated and place electronic components firmly and squarely in the corresponding cavities of left housing half. With components properly in place, make sure all wires and the ribbon cable are secured in the wire traps and channels. Be sure there will not be interferences prior to installing the right housing half-cover.

Carefully place right housing half-cover over the electronics assembly and onto the left housing half. Lightly secure the two housing halves together with seven screws (27). Check for the proper functionality of the slide button (24).

Carefully install front gearing mechanism and secure with four screws (13). Go back and hand tighten the seven housing screws. Install a battery and actuate paddle trigger to assure the proper operation of tool.