



SERVICE PARTS LIST

BULLETIN NO.
54-26-4000

SPECIFY CATALOG NO. AND SERIAL NO. WHEN ORDERING PARTS		REVISED BULLETIN	DATE
M18™ FUEL™ 3/8" Mid Torque Impact Wrench w/ Friction Ring			Aug. 2020
CATALOG NO.	2960-20	STARTING SERIAL	L78A
			WIRING INSTRUCTION SEE PAGE 2

EXAMPLE:
00 0 Component Parts (Small #)
Are Included When Ordering
The Assembly (Large #).

FIG.	PART NO.	DESCRIPTION OF PART	NO. REQ.
1	06-82-2368	M3.5 x 16mm Pan Hd. ST T-10 Screw	(9)
10	43-44-7037	Gasket	(1)
24	34-40-1885	O-Ring, 3/8" Anvil	(1)
25	44-90-1050	Friction Ring, 3/8" Anvil	(1)

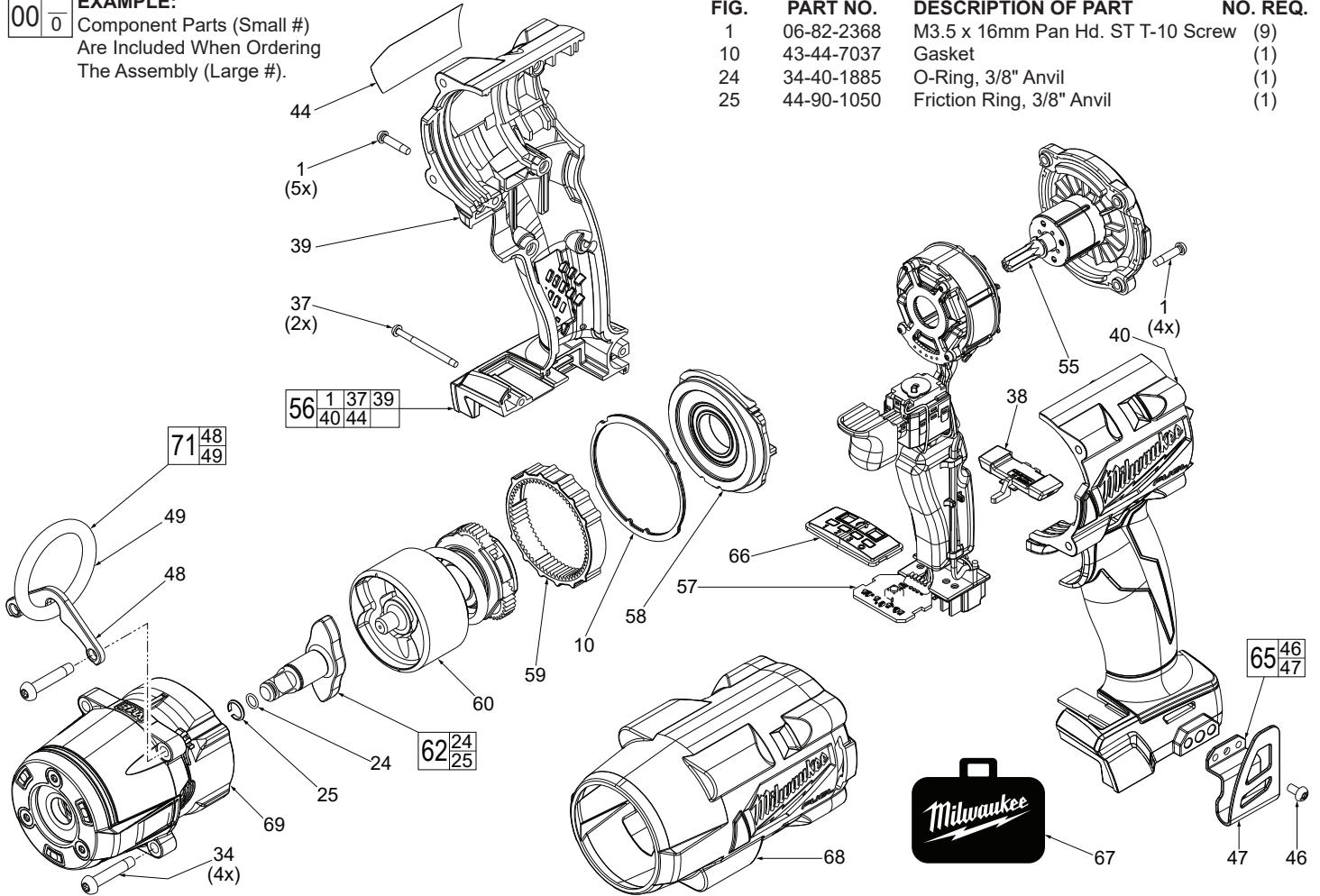

LUBRICATION NOTES:
Type 'J' Grease
No. 49-08-4220, 1 lb. can

NOTE: When servicing, remove 90-95% of the existing grease prior to installing Type 'J'. Original grease may be similar in color but not compatible with 'J'. Prior to reinstalling, clean gear assemblies with a clean, dry cloth. Lightly coat all parts highlighted here with 'J' grease. Apply a greater amount of grease to all internal and external gear teeth.

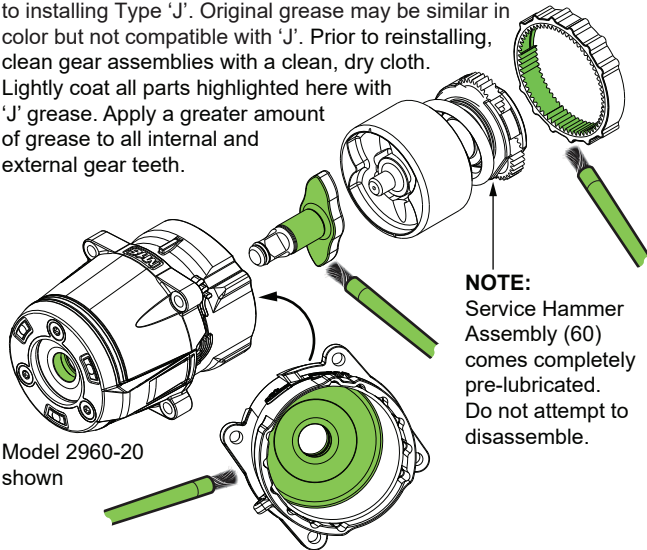
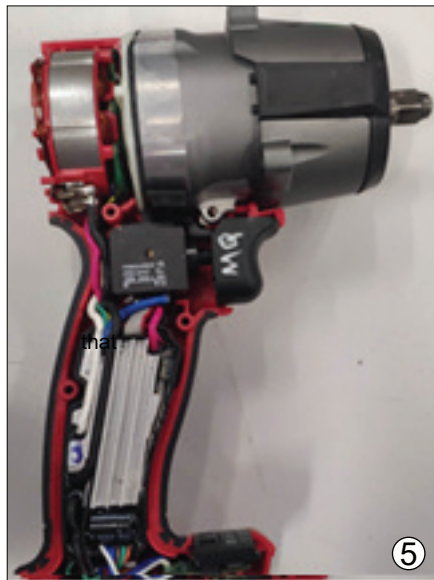
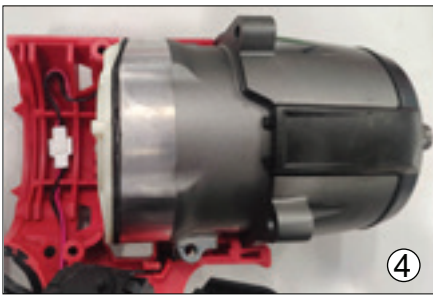

FIG.	PART NO.	DESCRIPTION OF PART	NO. REQ.
34	06-82-2366	M5 x 26.5mm Pan Hd. ST T-25 Screw	(4)
37	06-82-2367	M3 x 38mm Pan Hd. ST T-10 Screw	(2)
38	42-42-2735	Forward/Reverse Shuttle	(1)
39	-----	Right Housing Halve-Cover	(1)
40	-----	Left Housing Halve-Support	(1)
44	12-20-9100	Service Nameplate	(1)
46	06-82-2500	6-32 x 7mm Pan Hd T-15 Screw	(1)
47	-----	Belt Hook	(1)
48	-----	Tether Stamping	(1)
49	-----	Tether Ring	(1)
55	16-01-3040	Rotor Assembly	(1)
56	31-44-7007	Housing Kit	(1)
57	14-20-5020	Electronics Assembly, 3/8"	(1)
58	44-66-2675	End Cap Assembly	(1)
59	32-65-0385	Ring Gear	(1)
60	14-30-2960	Hammer Assembly, 3/8" Anvil	(1)
62	42-06-2960	Anvil Assembly, 3/8"	(1)
65	42-70-0950	Belt Clip Kit	(1)
66	45-24-2854	Mode Selector Assembly	(1)
67	42-55-6375	Blow Molded Carrying Case	(1)
68	49-16-2960	Rubber Boot, Accessory	(1)
69	28-50-2960	Gearcase Assembly, 3/8" Anvil	(1)
71	49-16-2962	Tether Ring Kit, Accessory	(1)



1. Install the HV (ground) terminal being sure the clip is inserted in housing cavity. Place ground wire in wire channel and route as shown.
2. Place gearcase assembly in housing half and secure with two gearcase screws.
3. Install the PCBA in housing half. Place mode selector assembly as shown.
4. Join the connector of shadowless LED assembly with connector on electronics assembly. Route wires in traps as shown.
5. Place into housing half the remaining components of the electronics assembly (stator, on-off switch and forward/reverse shuttle).
6. Install the housing cover onto the housing support. Secure housing halves with screws. Secure gearcase assembly to housing assembly with remaining two screws.

Not shown:
Install rotor assembly onto rear of housing assembly and secure with four screws.

As an aid to reassembly, take notice of wire routing and position in wire guides and traps while dismantling tool.

Be sure that all components of electronics kit are seated firmly and squarely in the handle recesses.

Avoid pinched wires, be sure that all wires and sleeves are pressed completely down in wire guides and traps.

Prior to securing the handle cover onto the handle support, be sure that there are no interferences.

Before installing the battery, check for proper functionality of shuttle and triggers.

Install battery and depress switch trigger to assure tool is operating properly.