

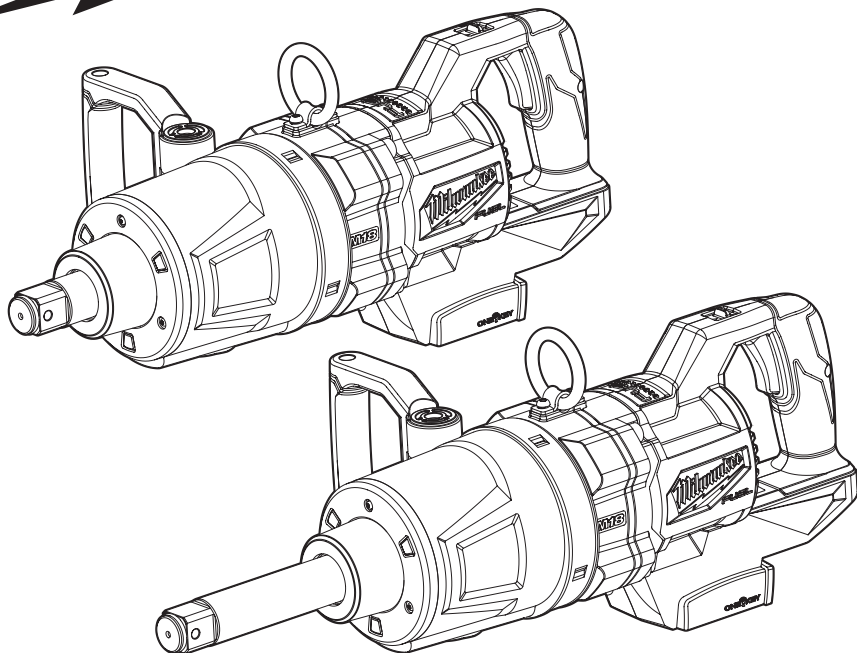



## OPERATOR'S MANUAL



Cat. No. / No de cat.  
2868-20, 2869-20

### M18 FUEL™ 1" D-HANDLE HIGH TORQUE IMPACT WRENCH WITH ONE-KEY™

 **WARNING** To reduce the risk of injury, user must read and understand operator's manual.



## GENERAL POWER TOOL SAFETY WARNINGS

**⚠WARNING** Read all safety warnings, instructions, illustrations and specifications provided with this power tool. Failure to follow all instructions listed below may result in electric shock, fire and/or serious injury. **Save all warnings and instructions for future reference.** The term "power tool" in the warnings refers to your mains-operated (corded) power tool or battery-operated (cordless) power tool.

### WORK AREA SAFETY

- **Keep work area clean and well lit.** Cluttered or dark areas invite accidents.
- **Do not operate power tools in explosive atmospheres, such as in the presence of flammable liquids, gases or dust.** Power tools create sparks which may ignite the dust or fumes.
- **Keep children and bystanders away while operating a power tool.** Distractions can cause you to lose control.

### ELECTRICAL SAFETY

- **Power tool plugs must match the outlet. Never modify the plug in any way. Do not use any adapter plugs with earthed (grounded) power tools.** Unmodified plugs and matching outlets will reduce risk of electric shock.
- **Avoid body contact with earthed or grounded surfaces, such as pipes, radiators, ranges and refrigerators.** There is an increased risk of electric shock if your body is earthed or grounded.
- **Do not expose power tools to rain or wet conditions.** Water entering a power tool will increase the risk of electric shock.
- **Do not abuse the cord. Never use the cord for carrying, pulling or unplugging the power tool. Keep cord away from heat, oil, sharp edges or moving parts.** Damaged or entangled cords increase the risk of electric shock.
- **When operating a power tool outdoors, use an extension cord suitable for outdoor use.** Use of a cord suitable for outdoor use reduces the risk of electric shock.
- **If operating a power tool in a damp location is unavoidable, use a ground fault circuit interrupter (GFCI) protected supply.** Use of an GFCI reduces the risk of electric shock.

### PERSONAL SAFETY

- **Stay alert, watch what you are doing and use common sense when operating a power tool. Do not use a power tool while you are tired or under the influence of drugs, alcohol or medication.** A moment of inattention while operating power tools may result in serious personal injury.
- **Use personal protective equipment. Always wear eye protection.** Protective equipment such as a dust mask, non-skid safety shoes, hard hat or hearing protection used for appropriate conditions will reduce personal injuries.
- **Prevent unintentional starting. Ensure the switch is in the off-position before connecting to power source and/or battery pack, picking up or carrying the tool.** Carrying power tools with your finger on the switch or energizing power tools that have the switch on invites accidents.
- **Remove any adjusting key or wrench before turning the power tool on.** A wrench or a key left attached to a rotating part of the power tool may result in personal injury.

- **Do not overreach. Keep proper footing and balance at all times.** This enables better control of the power tool in unexpected situations.
- **Dress properly. Do not wear loose clothing or jewelry. Keep your hair and clothing away from moving parts.** Loose clothes, jewelry or long hair can be caught in moving parts.
- **If devices are provided for the connection of dust extraction and collection facilities, ensure these are connected and properly used.** Use of dust collection can reduce dust-related hazards.
- **Do not let familiarity gained from frequent use of tools allow you to become complacent and ignore tool safety principles.** A careless action can cause severe injury within a fraction of a second.

### POWER TOOL USE AND CARE

- **Do not force the power tool. Use the correct power tool for your application.** The correct power tool will do the job better and safer at the rate for which it was designed.
- **Do not use the power tool if the switch does not turn it on and off.** Any power tool that cannot be controlled with the switch is dangerous and must be repaired.
- **Disconnect the plug from the power source and/or remove the battery pack, if detachable, from the power tool before making any adjustments, changing accessories, or storing power tools.** Such preventive safety measures reduce the risk of starting the power tool accidentally.
- **Store idle power tools out of the reach of children and do not allow persons unfamiliar with the power tool or these instructions to operate the power tool.** Power tools are dangerous in the hands of untrained users.
- **Maintain power tools and accessories. Check for misalignment or binding of moving parts, breakage of parts and any other condition that may affect the power tool's operation. If damaged, have the power tool repaired before use.** Many accidents are caused by poorly maintained power tools.
- **Keep cutting tools sharp and clean.** Properly maintained cutting tools with sharp cutting edges are less likely to bind and are easier to control.
- **Use the power tool, accessories and tool bits etc. in accordance with these instructions, taking into account the working conditions and the work to be performed.** Use of the power tool for operations different from those intended could result in a hazardous situation.
- **Keep handles and grasping surfaces dry, clean and free from oil and grease.** Slippery handles and grasping surfaces do not allow for safe handling and control of the tool in unexpected situations.

### BATTERY TOOL USE AND CARE

- **Recharge only with the charger specified by the manufacturer.** A charger that is suitable for one type of battery pack may create a risk of fire when used with another battery pack.
- **Use power tools only with specifically designated battery packs.** Use of any other battery packs may create a risk of injury and fire.
- **When battery pack is not in use, keep it away from other metal objects, like paper clips, coins, keys, nails, screws or other small metal objects, that can make a connection from one terminal to another.** Shorting the battery terminals together may cause burns or a fire.

- **Under abusive conditions, liquid may be ejected from the battery; avoid contact. If contact accidentally occurs, flush with water. If liquid contacts eyes, additionally seek medical help.** Liquid ejected from the battery may cause irritation or burns.
- **Do not use a battery pack or tool that is damaged or modified.** Damaged or modified batteries may exhibit unpredictable behavior resulting in fire, explosion or risk of injury.
- **Do not expose a battery pack or tool to fire or excessive temperature.** Exposure to fire or temperature above 265°F (130°C) may cause explosion.
- **Follow all charging instructions and do not charge the battery pack or tool outside the temperature range specified in the instructions.** Charging improperly or at temperatures outside the specified range may damage the battery and increase the risk of fire.

## SERVICE

- **Have your power tool serviced by a qualified repair person using only identical replacement parts.** This will ensure that the safety of the power tool is maintained.
- **Never service damaged battery packs.** Service of battery packs should only be performed by the manufacturer or authorized service providers.

## SPECIFIC SAFETY RULES FOR IMPACT WRENCHES

- **Wear ear protectors when impact drilling.** Exposure to noise can cause hearing loss.
- **Use only sockets and other accessories specifically designed for use on impact wrenches and drivers.** Other sockets and accessories might shatter or break causing injury.
- **If using with a lanyard, do not exceed maximum capacity marked on the lanyard label.** Always determine the weight of the product, with all accessories, when selecting the appropriate lanyard system. Exceeding maximum capacity may result in serious injury. See specifications for tool and battery weight.
- **For best results, use with energy absorbing lanyards.** Ropes, straps or chains may break and cause failure. Do not use with lanyards at full tension.
- **Chemical Burn Hazard. Keep coin cell battery away from children.**
- **AWARNING** To reduce the risk of injury, when working in dusty situations, wear appropriate respiratory protection or use an OSHA compliant dust extraction solution.
- **Always use common sense and be cautious when using tools.** It is not possible to anticipate every situation that could result in a dangerous outcome. Do not use this tool if you do not understand these operating instructions or you feel the work is beyond your capability; contact Milwaukee Tool or a trained professional for additional information or training.
- **Maintain labels and nameplates.** These carry important information. If unreadable or missing, contact a MILWAUKEE service facility for a free replacement.
- **AWARNING** Some dust created by power sanding, sawing, grinding, drilling, and other construction activities contains chemicals known to cause cancer, birth defects or other reproductive harm. Some examples of these chemicals are:
  - lead from lead-based paint
  - crystalline silica from bricks and cement and other masonry products, and
  - arsenic and chromium from chemically-treated lumber.
 Your risk from these exposures varies, depending on how often you do this type of work. To reduce your

exposure to these chemicals: work in a well ventilated area, and work with approved safety equipment, such as those dust masks that are specially designed to filter out microscopic particles.

## SYMBOLOLOGY

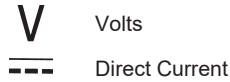

- $n_0$  XXXX min<sup>-1</sup> No Load Revolutions per Minute (RPM)
- $n$  XXXX min<sup>-1</sup> Impacts per Minute Under Load (IPM)
- UL Listing for Canada and U.S.

## SPECIFICATIONS

Volts.....	18 DC
Battery Type.....	M18™
Charger Type.....	M18™
No Load RPM.....	0-1200
IPM.....	0-1440
Recommended Ambient Operating Temperature.....	0°F to 125°F
<b>Cat. No.</b> .....	<b>2868-20</b>
Anvil Type.....	1" Square-Ring
Weight.....	21 lbs (Tool-Only)
Weight.....	24.4 lbs (With heaviest compatible battery pack)
<b>Cat. No.</b> .....	<b>2869-20</b>
Anvil Type.....	Extended 1" Square-Ring
Weight.....	23.2 lbs (Tool-Only)
Weight.....	26.6 lbs (With heaviest compatible battery pack)

## FUNCTIONAL DESCRIPTION

Cat. No. 2868-20

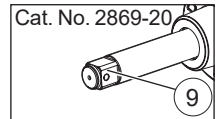
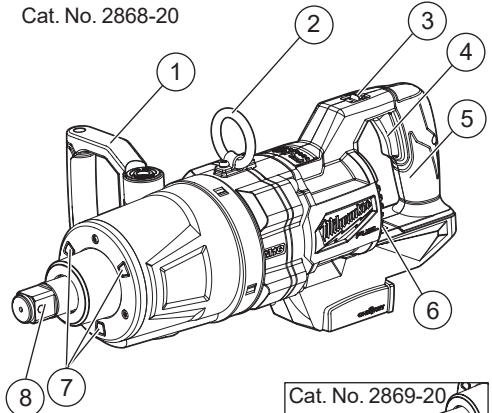

1. Side handle
2. Tool hanger
3. Control switch
4. Trigger
5. Handle
6. MODE selector (not shown)
7. LED
8. Square drive anvil with friction ring
9. Extended square drive anvil with friction ring

## ASSEMBLY

**⚠WARNING** Recharge only with the charger specified for the battery. For specific charging instructions, read the operator's manual supplied with your charger and battery.

### Removing/Inserting the Battery

To **remove** the battery, push in the release buttons and pull the battery pack away from the tool.

**⚠WARNING** Always remove battery pack before changing or removing accessories.

To **insert** the battery, slide the pack into the body of the tool. Make sure it latches securely into place.

**⚠WARNING** Only use accessories specifically recommended for this tool. Others may be hazardous.

### Installing the Side Handle

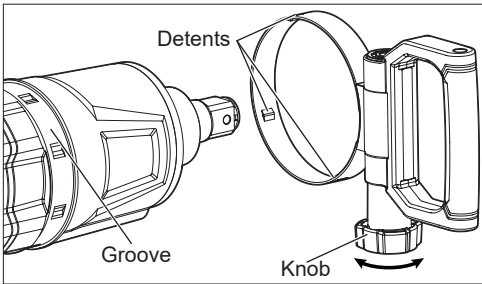

1. To **install** the side handle, loosen the side handle knob until the ring loosens.
2. Slide the ring over the front of the tool until the detents are resting in the groove.
3. Tighten the side handle knob until it is secure.
4. To **adjust** the side handle, loosen the knob and rotate to the desired position. Tighten securely.
5. To **remove** the side handle, loosen the side handle knob until the side handle can be removed.

### Attaching and Removing the Tool Hanger

1. To **attach**, place the hanger ring through the tool hanger.
2. Position the tool hanger on the tool over the two screw holes.
3. Insert the two screws. Hand tighten the screws.
4. To **remove**, reverse the procedure.

### Attaching and Removing Accessories

1. Use only the appropriate size Square Drive Sockets.
2. To attach a socket, align the accessory with the anvil and push it firmly over the retaining ring.
3. To remove the accessory, pull the accessory off the anvil.

**⚠WARNING** Use only sockets and other accessories specifically designed for use on impact wrenches and drivers. Other sockets and accessories might shatter or break causing injury.

### ONE-KEY™

To learn more about the ONE-KEY™ functionality for this tool, go to download the ONE-KEY™ app, visit the App Store or Google Play from your smart device.

## Setting the MODES in the ONE-KEY™ App

The modes can be customized in the ONE-KEY™ app to the user's preferences for the application. The options available for customization are:

### UNIVERSAL SETTINGS (affect all MODES)

**Worklight Duration** - Set the length of time the worklight remains on after the trigger is pulled.

**Brightness** - Set the brightness of the worklight.

**On-Tool Reset** - Enable or disable the tool reset. Set the On-Tool Reset to ON to allow the MODES to be reset to factory defaults when the Mode Selector Button on the tool is pressed for 5 seconds.

### To set the Drive Control Settings:

Two types of drive control are available, Custom Drive Control and Lug Nut Control. In the ONE-KEY™ app, select the MODE to be updated, then select TASK to pick Custom Drive Control or Lug Nut Control. The task attributes will be displayed.

#### •Custom Drive Control

Set the Max Speed, Bolt Removal, Precision Mode, and Trigger Ramp-Up for the mode.

#### •Lug Nut Control (available on 2869-20 only)

Set the Trigger Ramp-Up, and review the Torque Level (estimate) and the Star Pattern for the mode.

The tool is shipped with the MODES preset, as follows:

	MODE 1	MODE 2	MODE 3	MODE 4
<b>Control Type</b>	Custom Drive	Custom Drive	Custom Drive	Custom Drive
<b>Max Speed (forward)</b>	600	700	900	1200
<b>Bolt Removal (reverse)</b>	1200	1200	1200	1200
<b>Precision Mode</b>	Off	Off	Off	Off
<b>Trigger Ramp-Up</b>	Shorter	Shorter	Shorter	Shorter

### MODE SETTINGS

**Max Speed** - Select the max RPM to be reached when running the tool in *forward*.

**Bolt Removal** - Select the max RPM to be reached when running the tool in *reverse*.

**Precision Mode** - Enable or disable, and set the limit on the torque output of the tool. For maximum torque output, set the Precision Mode to OFF. To control the torque, set the Precision mode to ON and select the level. For lower torque applications select lower levels, and for higher torque applications, select higher levels. For torque-specific applications, confirm the final tightening torque with a calibrated torque wrench.

**Trigger Ramp-Up** - Set the length of time it takes for the tool to reach full speed.

**Torque Level (Estimate)** (2869-20 only) - Review the torque range (350-450 ft-lbs). For precision applications, confirm the final tightening torque with a calibrated device.

**Star Patterns** (2869-20 only) - Review the star patterns for bolt installation/removal.

## OPERATION

**WARNING** To reduce the risk of injury, always wear proper eye protection marked to comply with ANSI Z87.1.

When working in dusty situations, wear appropriate respiratory protection or use an OSHA compliant dust extraction solution.

Always remove battery pack before changing or removing accessories. Only use accessories specifically recommended for this tool. Others may be hazardous.

### Using the MODE Selector

The mode selector button  is used to select the mode set in the ONE-KEY™ app.

To select the mode:

1. Pull and release the trigger to turn on the tool. The current mode indicator is lit.
2. Press the mode selector button  to cycle through the 4 modes. When the desired mode indicator is lit, begin work.
3. The ONE-KEY™ Indicator lights, to indicate the following:

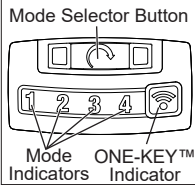

ONE-KEY™ Indicator	
Solid Blue	Wireless mode is active and ready to be configured via the ONE-KEY™ app.
Blinking Blue	Tool is actively communicating with the ONE-KEY™ app.
Blinking Red	Tool is in security lockout and can be unlocked by the owner via the ONE-KEY™ app.

### Using the Control Switch

The control switch may be set to three positions: forward, reverse and lock. Due to a lockout mechanism, the control switch can only be adjusted when the trigger is not pressed. Always allow the motor to come to a complete stop before using the control switch.

1. For **forward** (clockwise) rotation, push the control switch in the direction shown. **Check the direction of rotation before use.**
2. For **reverse** (counter-clockwise) rotation, push the control switch in the direction shown. **Check the direction of rotation before use.**
3. To **lock** the trigger, push the control switch to the center position. The trigger will not work when the control switch is in the locked position.

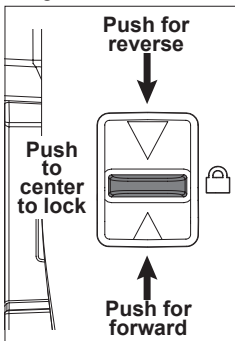

Always remove the battery pack before performing maintenance or changing accessories. Always lock the trigger or remove the battery pack before storing the tool and any time the tool is not in use.

## Starting, Stopping and Controlling Speed

These tools may be operated at any speed from 0 to full speed.

1. To **start** the tool, pull the trigger.  
**NOTE:** An LED is turned on when the trigger is pulled.
2. To **vary** the driving speed, increase or decrease pressure on the trigger. The further the trigger is pulled, the greater the speed, up to the max RPM set by the MODE.
3. To **stop** the tool, release the trigger.

## Impacting Techniques

The longer a bolt, screw, or nut is impacted, the tighter it will become. To help prevent damaging the fasteners or workpieces, avoid excessive impacting. Be particularly careful when impacting smaller fasteners because they require less impacting to reach optimum torque.

Practice with various fasteners, noting the length of time required to reach the desired torque. Check the tightness with a hand-torque wrench. If the fasteners are too tight, reduce the impacting time. If they are not tight enough, increase the impacting time.

Oil, dirt, rust or other matter on the threads or under the head of the fastener affects the degree of tightness. The torque required to loosen a fastener averages 75% to 80% of the tightening torque, depending on the condition of the contacting surfaces.

On light gasket jobs, run each fastener down to a relatively light torque and use a hand torque wrench for final tightening.

## MAINTENANCE

**WARNING** To reduce the risk of injury, always unplug the charger and remove the battery pack from the charger or tool before performing any maintenance. Never disassemble the tool, battery pack or charger. Contact a MILWAUKEE service facility for ALL repairs.

### Maintaining Tool

Keep your tool, battery pack and charger in good repair by adopting a regular maintenance program. Inspect your tool for issues such as undue noise, misalignment or binding of moving parts, breakage of parts, or any other condition that may affect the tool operation. Return the tool, battery pack, and charger to a MILWAUKEE service facility for repair. After six months to one year, depending on use, return the tool, battery pack and charger to a MILWAUKEE service facility for inspection.

If the tool does not start or operate at full power with a fully charged battery pack, clean the contacts on the battery pack. If the tool still does not work properly, return the tool, charger and battery pack, to a MILWAUKEE service facility for repairs.

## ONE-KEY™

**⚠WARNING** Chemical Burn Hazard. This device contains a lithium button/coin cell battery. A new or used battery can cause severe internal burns and lead to death in as little as 2 hours if swallowed or enters the body. Always secure the battery cover. If it does not close securely, stop using the device, remove the batteries, and keep it away from children. If you think batteries may have been swallowed or entered the body, seek immediate medical attention.



### Internal Battery

An internal battery is used to facilitate full ONE-KEY™ functionality..

To replace the battery:

1. Remove the battery pack.
2. Remove the screw(s) and open the battery door.
3. Remove the old battery, keep it away from children, and dispose of it properly.
4. Insert the new battery (3V CR2032), with the positive side facing up.
5. Close the battery door and tighten the screw(s) securely.

**⚠WARNING** To reduce the risk of personal injury and damage, never immerse your tool, battery pack or charger in liquid or allow a liquid to flow inside them.

### Cleaning

Clean dust and debris from vents. Keep handles clean, dry and free of oil or grease. Use only mild soap and a damp cloth to clean, since certain cleaning agents and solvents are harmful to plastics and other insulated parts. Some of these include gasoline, turpentine, lacquer thinner, paint thinner, chlorinated cleaning solvents, ammonia and household detergents containing ammonia. Never use flammable or combustible solvents around tools.

### Repairs

For repairs, return the tool, battery pack and charger to the nearest authorized service center.

## ACCESSORIES

**⚠WARNING** Use only recommended accessories. Others may be hazardous.