



SERVICE PARTS LIST

BULLETIN NO.
54-22-2411

| SPECIFY CATALOG NO. AND SERIAL NO. WHEN ORDERING PARTS | | REVISED BULLETIN | DATE |
|--|----------------|---------------------------|-----------|
| M18 FUEL MULTI-TOOL | | 54-22-2410 | Oct. 2020 |
| CATALOG NO. | 2836-20 | WIRING INSTRUCTION | |
| STARTING SERIAL NO. | L53B | See Reverse Side | |

★ = Part number change from previous service parts list.

EXAMPLE:
Component Parts (Small #)
Are Included When Ordering
The Assembly (Large #).

See bottom of page 2 for
Torque Specification Chart

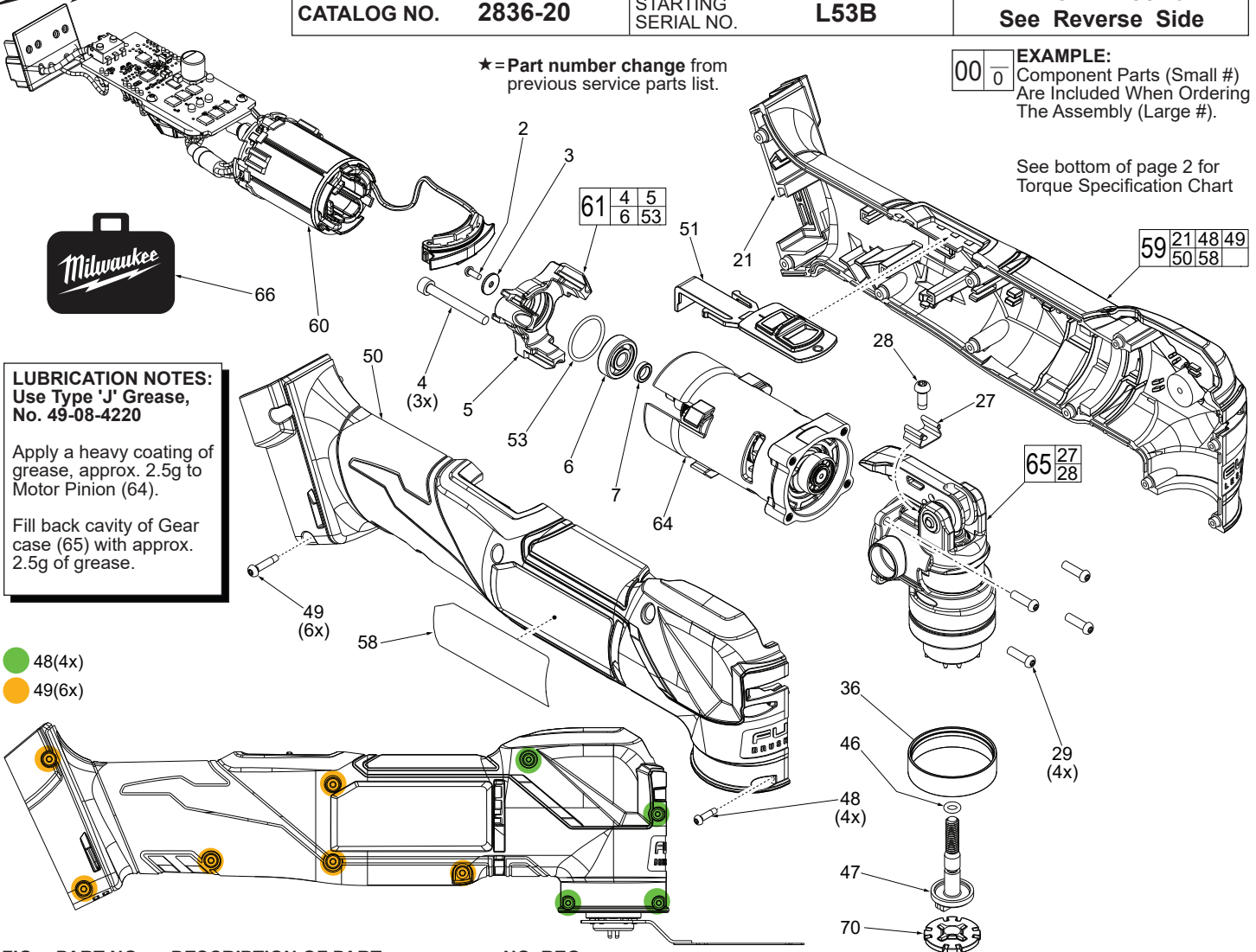

LUBRICATION NOTES:
Use Type 'J' Grease,
No. 49-08-4220

Apply a heavy coating of
grease, approx. 2.5g to
Motor Pinion (64).

Fill back cavity of Gear
case (65) with approx.
2.5g of grease.

- 48(4x)
- 49(6x)

| FIG. | PART NO. | DESCRIPTION OF PART | NO. REQ. |
|------|------------|--|----------|
| 2 | 05-88-1015 | M2.5 x 6mm Pan Hd. Phillips Screw | (1) |
| 3 | 45-88-0232 | 19mm Flat Washer | (1) |
| 4 | ----- | M4 x 35mm Cap Hd. Hex Recess Mach. Sc. | (3) |
| 5 | ----- | Motor End Plate | (1) |
| 6 | 02-04-0223 | Ball Bearing | (1) |
| 7 | 42-24-0212 | Bushing | (1) |
| 21 | ----- | Left Housing Halve with Cushions | (1) |
| 27 | 42-70-0510 | Quick Release Clip | (1) |
| 28 | 05-78-0105 | M4 x 10mm Pan Hd. Taptite T-20 Screw | (1) |
| 29 | 05-78-1010 | M3.5 x 12mm Pan Hd. T-10 Mach. Screw | (4) |
| 36 | 45-22-0026 | Rubber Sleeve | (1) |
| 46 | 34-40-0431 | O-Ring | (1) |
| 47 | 06-75-1015 | Blade Fastener | (1) |
| 48 | 06-82-2395 | M2.6 x 10mm Pan Hd. ST T-8 Screw | (4) |
| 49 | 06-82-1080 | M3 x 14mm Pan Hd. ST T-10 Screw | (6) |
| 50 | ----- | Right Housing Halve with Cushions | (1) |
| 51 | 45-72-0024 | Slide Lever | (1) |
| 53 | 34-40-0147 | O-Ring | (1) |
| 58 | 12-20-0446 | Service Nameplate | (1) |
| ★59 | 31-44-0244 | Housing Kit | (1) |
| ★60 | 14-20-0188 | Electronics Kit | (1) |
| 61 | 14-46-0205 | Motor End Plate Kit | (1) |
| 64 | 14-50-0029 | Rotor/Jam Sleeve Assembly | (1) |
| 65 | 14-29-0068 | Gearcase Assembly | (1) |
| 66 | 42-55-2866 | Contractor Bag | (1) |
| 70 | 48-03-2526 | Adapter (Accessory - Sold Separately) | (1) |
| 72 | 49-90-2430 | Depth Stop (Accessory - Sold Separately) | (1) |
| 73 | 49-90-2420 | Dust Extractor (Accessory - Sold Separately) | (1) |

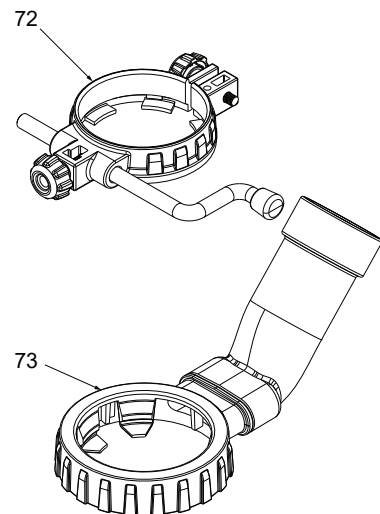

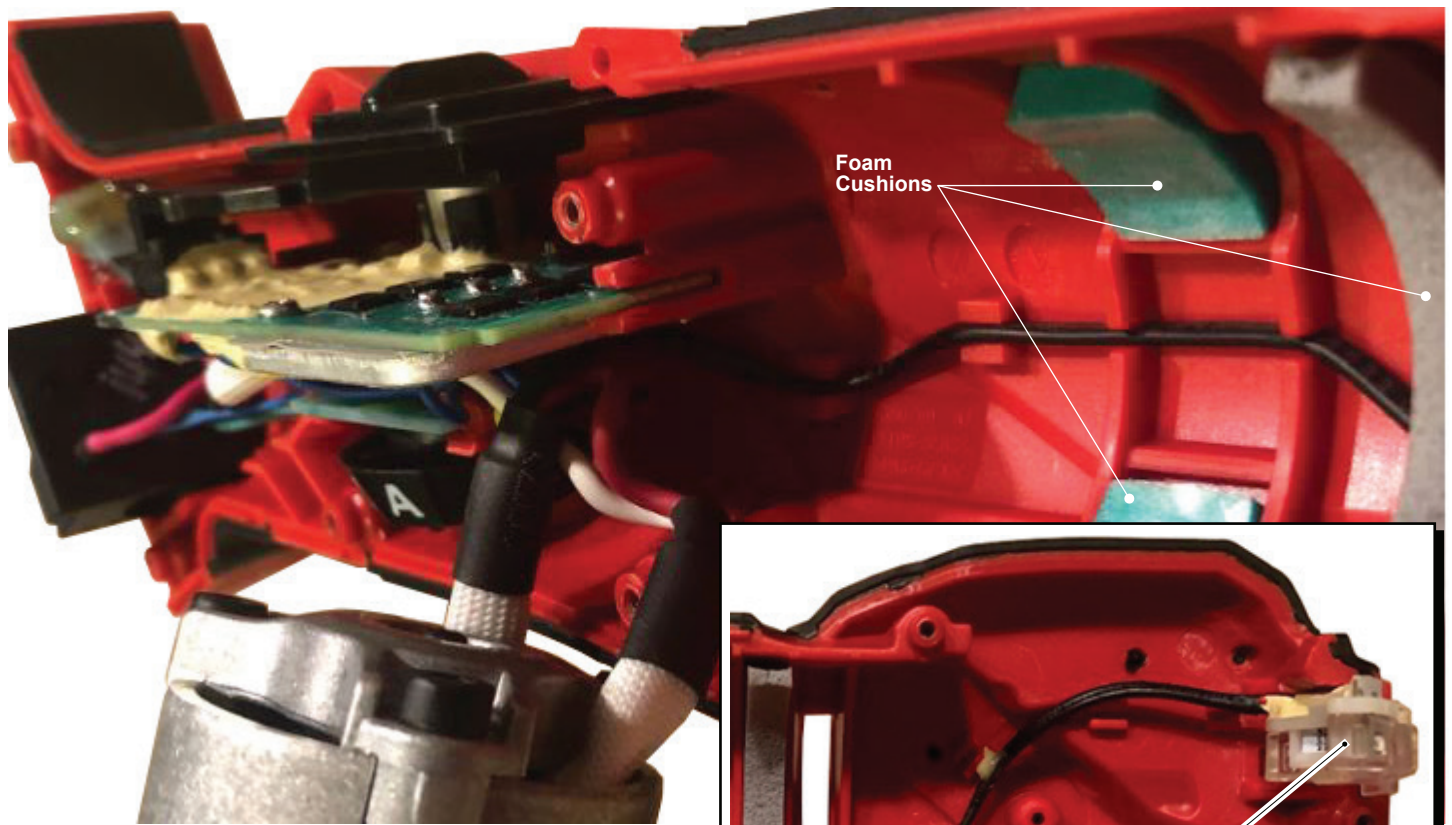

As an aid to reassembly, take notice of wire routings and position in wire guides and traps while dismantling tool.

Be sure that all components of electronics kit are seated firmly and squarely in housing recesses.

Avoid pinched wires, be sure that all wires and sleeves are pressed completely down in wire traps.

Prior to securing housing cover onto the housing support, be sure that there are no interferences.

Before installing the battery, check for proper functionality of shuttles and triggers.

Install battery and depress switch triggers to assure tool is operating properly.

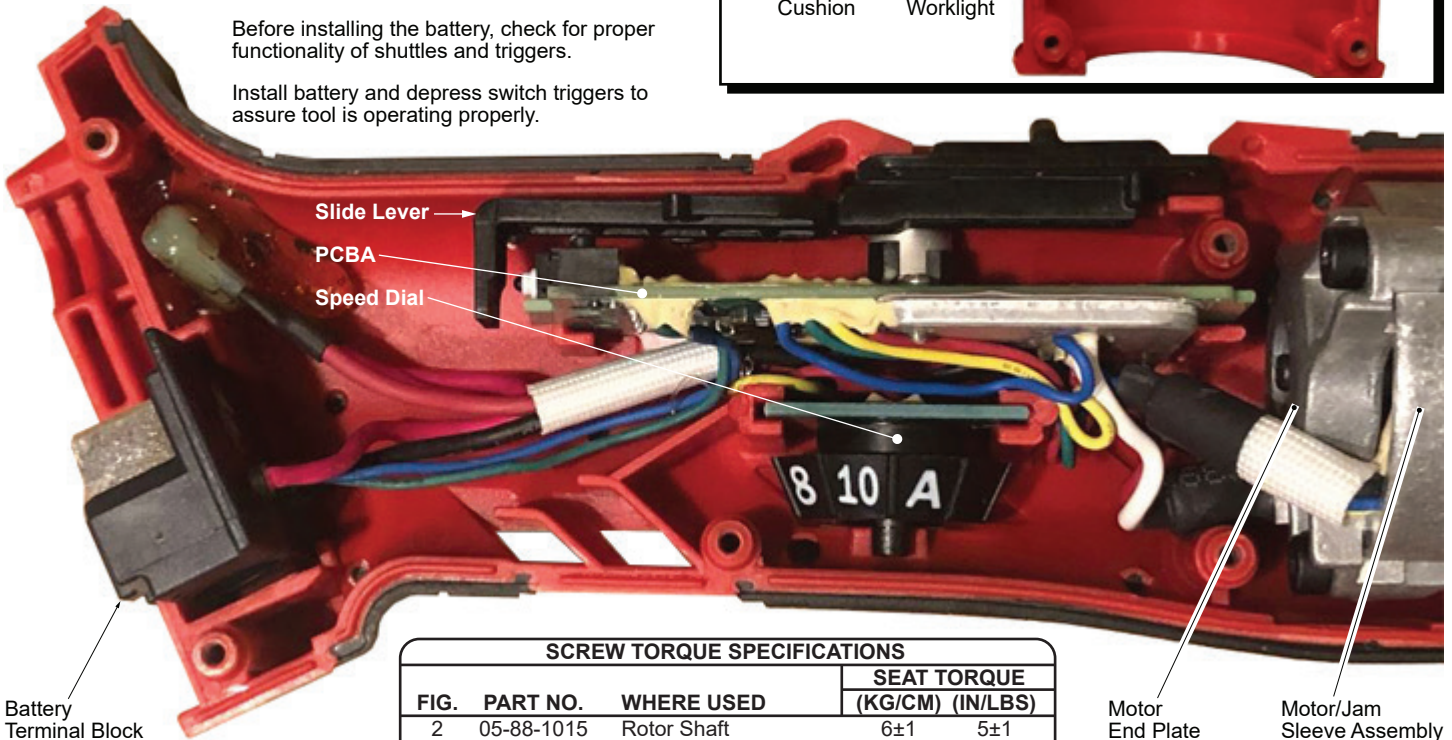
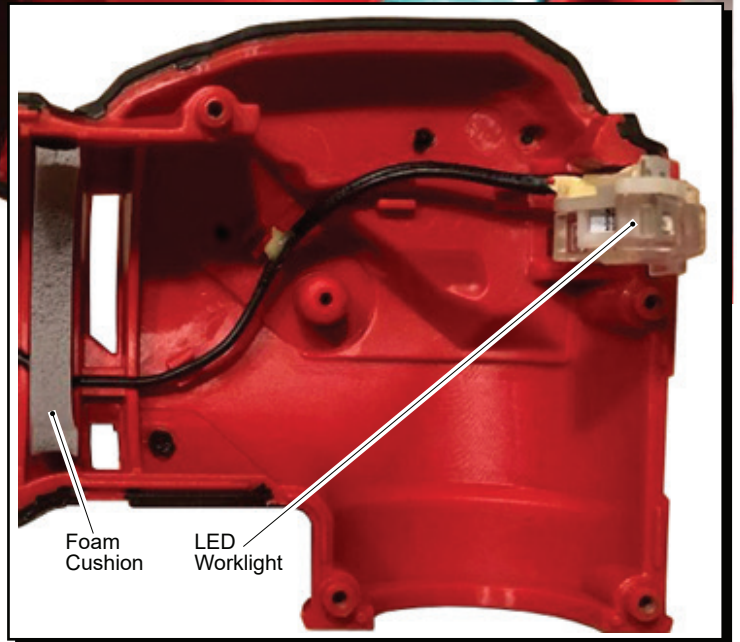

SCREW TORQUE SPECIFICATIONS

| FIG. | PART NO. | WHERE USED | SEAT TORQUE | |
|------|------------|--------------------|-------------|----------|
| | | | (KG/CM) | (IN/LBS) |
| 2 | 05-88-1015 | Rotor Shaft | 6±1 | 5±1 |
| 4 | ----- | Motor End Plate | 26±2 | 22±2 |
| 28 | 05-78-0105 | Quick Release Clip | 16±2 | 14±2 |
| 29 | 05-78-1010 | Gearbox | 18±2 | 15.5±2 |
| 48 | 06-82-2395 | Housing Halve | 5±1 | 4±1 |
| 49 | 06-82-1080 | Housing Halve | 8±1 | 7±1 |