

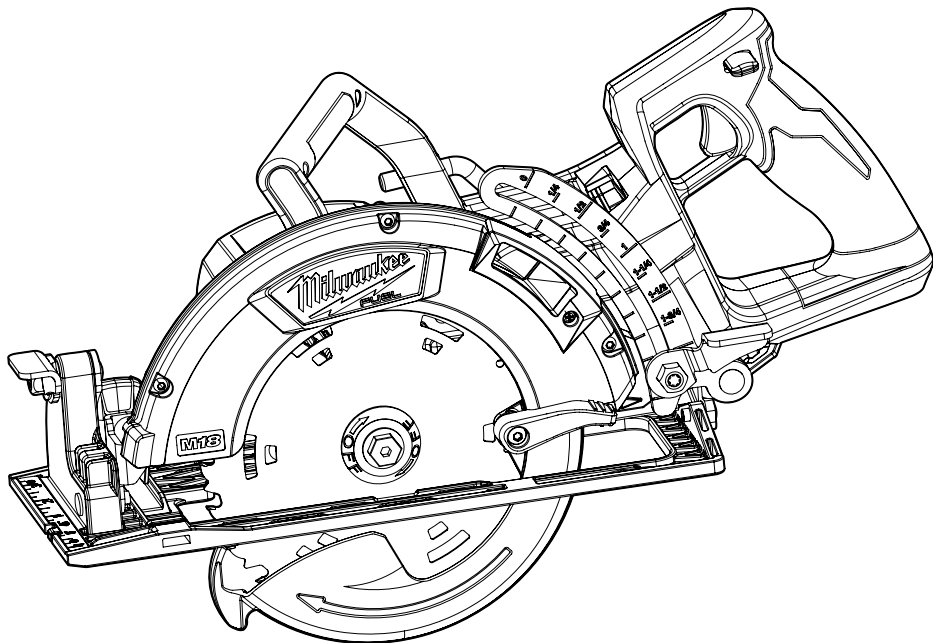

OPERATOR'S MANUAL



Cat. No.
2830-20

M18 FUEL™ 7-1/4" REAR HANDLE CIRCULAR SAW



WARNING To reduce the risk of injury, user must read and understand operator's manual.

GENERAL POWER TOOL SAFETY WARNINGS

⚠WARNING Read all safety warnings, instructions, illustrations and specifications provided with this power tool. Failure to follow all instructions listed below may result in electric shock, fire and/or serious injury. **Save all warnings and instructions for future reference.** The term "power tool" in the warnings refers to your mains-operated (corded) power tool or battery-operated (cordless) power tool.

WORK AREA SAFETY

- **Keep work area clean and well lit.** Cluttered or dark areas invite accidents.
- **Do not operate power tools in explosive atmospheres, such as in the presence of flammable liquids, gases or dust.** Power tools create sparks which may ignite the dust or fumes.
- **Keep children and bystanders away while operating a power tool.** Distractions can cause you to lose control.

ELECTRICAL SAFETY

- **Power tool plugs must match the outlet. Never modify the plug in any way. Do not use any adapter plugs with earthed (grounded) power tools.** Unmodified plugs and matching outlets will reduce risk of electric shock.
- **Avoid body contact with earthed or grounded surfaces, such as pipes, radiators, ranges and refrigerators.** There is an increased risk of electric shock if your body is earthed or grounded.
- **Do not expose power tools to rain or wet conditions.** Water entering a power tool will increase the risk of electric shock.
- **Do not abuse the cord. Never use the cord for carrying, pulling or unplugging the power tool. Keep cord away from heat, oil, sharp edges or moving parts.** Damaged or entangled cords increase the risk of electric shock.
- **When operating a power tool outdoors, use an extension cord suitable for outdoor use.** Use of a cord suitable for outdoor use reduces the risk of electric shock.
- **If operating a power tool in a damp location is unavoidable, use a ground fault circuit interrupter (GFCI) protected supply.** Use of an GFCI reduces the risk of electric shock.

PERSONAL SAFETY

- **Stay alert, watch what you are doing and use common sense when operating a power tool. Do not use a power tool while you are tired or under the influence of drugs, alcohol or medication.** A moment of inattention while operating power tools may result in serious personal injury.
- **Use personal protective equipment. Always wear eye protection.** Protective equipment such as a dust mask, non-skid safety shoes, hard hat or hearing protection used for appropriate conditions will reduce personal injuries.
- **Prevent unintentional starting. Ensure the switch is in the off-position before connecting to power source and/or battery pack, picking up or carrying the tool.** Carrying power tools with your finger on the switch or energizing power tools that have the switch on invites accidents.

- **Remove any adjusting key or wrench before turning the power tool on.** A wrench or a key left attached to a rotating part of the power tool may result in personal injury.
- **Do not overreach. Keep proper footing and balance at all times.** This enables better control of the power tool in unexpected situations.
- **Dress properly. Do not wear loose clothing or jewelry. Keep your hair and clothing away from moving parts.** Loose clothes, jewelry or long hair can be caught in moving parts.
- **If devices are provided for the connection of dust extraction and collection facilities, ensure these are connected and properly used.** Use of dust collection can reduce dust-related hazards.
- **Do not let familiarity gained from frequent use of tools allow you to become complacent and ignore tool safety principles.** A careless action can cause severe injury within a fraction of a second.

POWER TOOL USE AND CARE

- **Do not force the power tool. Use the correct power tool for your application.** The correct power tool will do the job better and safer at the rate for which it was designed.
 - **Do not use the power tool if the switch does not turn it on and off.** Any power tool that cannot be controlled with the switch is dangerous and must be repaired.
 - **Disconnect the plug from the power source and/ or remove the battery pack, if detachable, from the power tool before making any adjustments, changing accessories, or storing power tools.** Such preventive safety measures reduce the risk of starting the power tool accidentally.
 - **Store idle power tools out of the reach of children and do not allow persons unfamiliar with the power tool or these instructions to operate the power tool.** Power tools are dangerous in the hands of untrained users.
 - **Maintain power tools and accessories. Check for misalignment or binding of moving parts, breakage of parts and any other condition that may affect the power tool's operation. If damaged, have the power tool repaired before use.** Many accidents are caused by poorly maintained power tools.
 - **Keep cutting tools sharp and clean.** Properly maintained cutting tools with sharp cutting edges are less likely to bind and are easier to control.
 - **Use the power tool, accessories and tool bits etc. in accordance with these instructions, taking into account the working conditions and the work to be performed.** Use of the power tool for operations different from those intended could result in a hazardous situation.
 - **Keep handles and grasping surfaces dry, clean and free from oil and grease.** Slippery handles and grasping surfaces do not allow for safe handling and control of the tool in unexpected situations.
- ### BATTERY TOOL USE AND CARE
- **Recharge only with the charger specified by the manufacturer.** A charger that is suitable for one type of battery pack may create a risk of fire when used with another battery pack.
 - **Use power tools only with specifically designated battery packs.** Use of any other battery packs may create a risk of injury and fire.

•When battery pack is not in use, keep it away from other metal objects, like paper clips, coins, keys, nails, screws or other small metal objects, that can make a connection from one terminal to another. Shorting the battery terminals together may cause burns or a fire.

•Under abusive conditions, liquid may be ejected from the battery; avoid contact. If contact accidentally occurs, flush with water. If liquid contacts eyes, additionally seek medical help. Liquid ejected from the battery may cause irritation or burns.

•Do not use a battery pack or tool that is damaged or modified. Damaged or modified batteries may exhibit unpredictable behavior resulting in fire, explosion or risk of injury.

•Do not expose a battery pack or tool to fire or excessive temperature. Exposure to fire or temperature above 265°F (130°C) may cause explosion.

•Follow all charging instructions and do not charge the battery pack or tool outside the temperature range specified in the instructions. Charging improperly or at temperatures outside the specified range may damage the battery and increase the risk of fire.

SERVICE

•Have your power tool serviced by a qualified repair person using only identical replacement parts. This will ensure that the safety of the power tool is maintained.

•Never service damaged battery packs. Service of battery packs should only be performed by the manufacturer or authorized service providers.

SPECIFIC SAFETY RULES FOR CIRCULAR SAWS

Cutting procedures

⚠ DANGER Keep hands away from cutting area and the blade. Keep your second hand on auxiliary handle, or motor housing. If both hands are holding the saw, they cannot be cut by the blade.

•Do not reach underneath the workpiece. The guard cannot protect you from the blade below the workpiece.

•Adjust the cutting depth to the thickness of the workpiece. Less than a full tooth of the blade teeth should be visible below the workpiece.

•Never hold the workpiece in your hands or across your leg while cutting. Secure the workpiece to a stable platform. It is important to support the work properly to minimize body exposure, blade binding, or loss of control.

•Hold the power tool by insulated gripping surfaces when performing an operation where the cutting tool may contact hidden wiring. Contact with a "live" wire will also make exposed metal parts of the power tool "live" and could give the operator an electric shock.

•When ripping, always use a rip fence or straight edge guide. This improves the accuracy of cut and reduces the chance of blade binding.

•Always use blades with correct size and shape (diamond versus round) of arbour holes. Blades that do not match the mounting hardware of the saw will run off-center, causing loss of control.

•Never use damaged or incorrect blade washers or bolt. The blade washers and bolt were specially designed for your saw, for optimum performance and safety of operation.

Further safety instructions for all saws Kickback causes and related warnings

- Kickback is a sudden reaction to a pinched, jammed, or misaligned saw blade, causing an uncontrolled saw to lift up and out of the workpiece toward the operator;
- When the blade is pinched or jammed tightly by the kerf closing down, the blade stalls and the motor reaction drives the unit rapidly back toward the operator;
- If the blade becomes twisted or misaligned in the cut, the teeth at the back edge of the blade can dig into the top surface of the wood causing the blade to climb out of the kerf and jump back toward the operator.

Kickback is the result of saw misuse and/or incorrect operating procedures or conditions and can be avoided by taking proper precautions as given below:

•Maintain a firm grip with both hands on the saw and position your arms to resist kickback forces. Position your body to either side of the blade, but not in line with the blade. Kickback could cause the saw to jump backwards, but kickback forces can be controlled by the operator, if proper precautions are taken.

•When blade is binding, or when interrupting a cut for any reason, release the trigger and hold the saw motionless in the material until the blade comes to a complete stop. Never attempt to remove the saw from the work or pull the saw backward while the blade is in motion or kickback may occur. Investigate and take corrective actions to eliminate the cause of blade binding.

•When restarting a saw in the workpiece, centre the saw blade in the kerf and check that saw teeth are not engaged into the material. If saw blade binds, it may walk up or kickback from the workpiece as the saw is restarted.

•Support large panels to minimise the risk of blade pinching and kickback. Large panels tend to sag under their own weight. Supports must be placed under the panel on both sides, near the line of cut and near the edge of the panel.

•Do not use dull or damaged blades. Unsharpened or improperly set blades produce narrow kerf causing excessive friction, blade binding and kickback.

•Blade depth and bevel adjusting locking levers must be tight and secure before making cut. If blade adjustment shifts while cutting, it may cause binding and kickback.

•Use extra caution when sawing into existing walls or other blind areas. The protruding blade may cut objects that can cause kickback.

Lower guard function

•Check lower guard for proper closing before each use. Do not operate the saw if lower guard does not move freely and close instantly. Never clamp or tie the lower guard into the open position. If saw is accidentally dropped, the lower guard may be bent. Raise the lower guard with the retracting handle and make sure it moves freely and does not touch the blade or any other part, in all angles and depths of cut.

•Check the operation of the lower guard spring. If the guard and the spring are not operating properly, they must be serviced before use. Lower guard may operate sluggishly due to damaged parts, gummy deposits, or a build-up of debris.

•The lower guard may be retracted manually only for special cuts such as "plunge cuts" and "compound cuts." Raise lower guard by retracting handle and as soon as blade enters the material, the lower guard must be released. For all other sawing, the lower guard should operate automatically.

FUNCTIONAL DESCRIPTION

•Always observe that the lower guard is covering the blade before placing saw down on bench or floor. An unprotected, coasting blade will cause the saw to walk backwards, cutting whatever is in its path. Be aware of the time it takes for the blade to stop after switch is released.

•**AWARNING** To reduce the risk of injury in applications that produce a considerable amount of dust, use an OSHA compliant dust extraction solution in accordance with the solution's operating instructions.

•Always use common sense and be cautious when using tools. It is not possible to anticipate every situation that could result in a dangerous outcome. Do not use this tool if you do not understand these operating instructions or you feel the work is beyond your capability; contact Milwaukee Tool or a trained professional for additional information or training.

•**Maintain labels and nameplates.** These carry important information. If unreadable or missing, contact a MILWAUKEE service facility for a free replacement.

•**AWARNING** Some dust created by power sanding, sawing, grinding, drilling, and other construction activities contains chemicals known to cause cancer, birth defects or other reproductive harm. Some examples of these chemicals are:

- lead from lead-based paint
- crystalline silica from bricks and cement and other masonry products, and
- arsenic and chromium from chemically-treated lumber.

Your risk from these exposures varies, depending on how often you do this type of work. To reduce your exposure to these chemicals: work in a well ventilated area, and work with approved safety equipment, such as those dust masks that are specially designed to filter out microscopic particles.

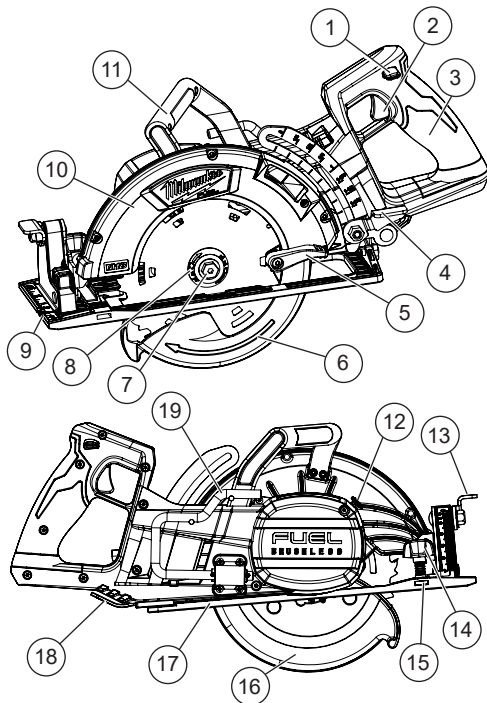

- | | |
|--------------------------|------------------------------|
| 1. Lock-off button | 11. Top handle |
| 2. Trigger | 12. Spindle lock button |
| 3. Handle | 13. Bevel adjusting lever |
| 4. Depth adjusting lever | 14. Rip fence adjusting knob |
| 5. Lower guard lever | 15. Rip fence slot |
| 6. Lower guard arrow | 16. Lower guard |
| 7. Blade bolt | 17. Shoe |
| 8. Blade flange | 18. Wrench/Storage |
| 9. Sight lines | 19. Rafter hook |
| 10. Upper guard | |

SYMBOLGY



Volts



Direct Current

n_r XXXX min⁻¹ No Load Revolutions per Minute (RPM)



UL Listing for Canada and U.S.

SPECIFICATIONS

Cat. No.	2830-20
Volts.....	18 DC
Battery Type.....	M18™
Charger Type.....	M18™
Recommended Ambient Operating Temperature.....	0°F to 125°F
No Load RPM.....	5800
Blade Size.....	7-1/4"™
Arbor.....	Diamond
Depth of Cut at 90°.....	0 to 2-1/2"
Depth of Cut at 45°.....	0 to 1-7/8"

ASSEMBLY

AWARNING Recharge only with the charger specified for the battery. For specific charging instructions, read the operator's manual supplied with your charger and battery.

Removing/Inserting the Battery

To remove the battery, push in the release buttons and pull the battery pack away from the tool.

AWARNING Always remove battery pack before changing or removing accessories.

To insert the battery, slide the pack into the body of the tool. Make sure it latches securely into place.

WARNING Only use accessories specifically recommended for this tool. Others may be hazardous.

Selecting Blade

Select a blade appropriate for your application. Refer to the "Accessories" section for a list of blades to be used for the proper applications of this tool.

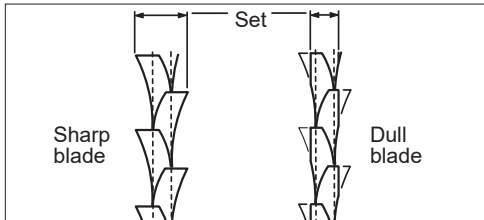

Always use sharp blades. Dull blades tend to overload the tool and increase the chance of KICKBACK. Only use thin kerf blades with a maximum safe operating speed greater than the no load RPM marked on the tool's nameplate. Read the blade manufacturer's instructions before use. Do not use any type of abrasive cut-off wheel or dry diamond cutting blades. Use the correct blade type for your application. Using the wrong blade may result in reduced performance or damage to the blade. Do not use blades that are cracked or have broken teeth. Do not sharpen ferrous metal cutting blades; see the blade manufacturer's recommendations regarding sharpening.

WARNING! Only use blades with diamond arbors. For blades with a knockout arbor, use the wrench supplied as a lever to pry out the diamond cutout.

Rip & Crosscut



A multi-purpose blade for ripping, cross cutting and mitering in hardwoods, softwoods, plywood and composition materials.

Framing-Rip



Designed for fast and accurate ripping along the grain in hard-or softwoods where a smooth cross cut is not necessary.

Plywood-Veneer



Recommended for cutting plywood, composition materials and all types of wood where a slightly smoother finish is necessary.

Finish & Trim



Especially designed for cross cutting and mitering in materials where a very smooth cut is necessary. Also cuts aluminum.

Checking the Operation of the Lower Guard

Check the operation and condition of the lower guard lever. If the guard and the lever are not operating properly, they must be serviced before use. Lower guard may operate sluggishly due to damaged parts, gummy deposits, or a buildup of debris.

1. Remove from battery pack before checking the lower guard.

2. Place the tool on its side.

NOTE: This procedure will not show proper lower guard operation if the tool is not on its side.

3. Grasp the lower guard by the sides and push it all the way back into the blade housing.

4. Release the lower guard.

- If the guard immediately springs back into place, it is working correctly and you may continue with use.
- If the guard does not immediately spring back into place, clean the upper and lower guards to remove all chips and debris. Then, check the operation again by starting with step 1.
- If the guard still does not immediately spring back into place, contact a MILWAUKEE service facility for repairs.

Installing Blade

1. Remove from battery pack
2. To remove blade bolt from spindle, push in spindle lock button while turning bolt clockwise with the wrench (provided with tool) until spindle locks. Remove outer blade washer and spring washer.

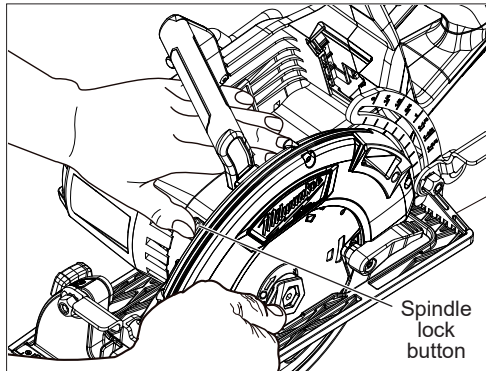

NOTE: Do not remove inner blade flange. Large diameter of inner flange should face the blade.

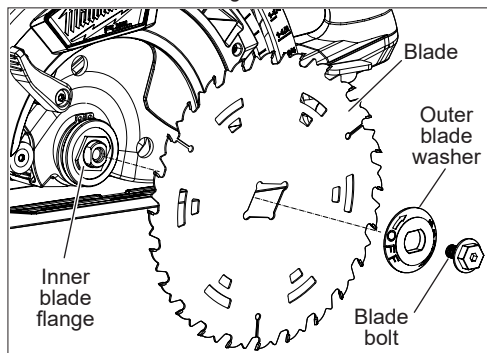

3. Push lower guard lever up to raise lower guard. Place blade on spindle with teeth pointing the same direction as the arrow on lower guard. Release lower guard lever.

4. Place outer blade washer, spring washer, and blade bolt on spindle.

5. Push in spindle lock button while turning bolt counterclockwise with the wrench until spindle locks. Tighten bolt securely.

6. To remove blade, reverse the above steps. Always clean dirt and sawdust from spindle, washers, upper guard and lower guard after use.

Adjusting Depth

1. Remove from battery pack
2. To adjust depth of cut, place saw on edge of workbench and pull up depth adjusting lever.

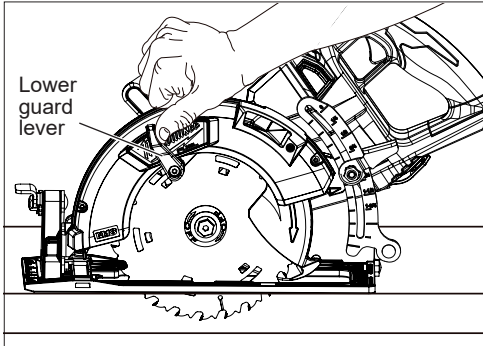

3. Keeping shoe flat against workbench, raise or lower saw to desired position. Lowering saw will increase depth of cut. Raising saw will decrease depth of cut. For proper depth setting, blade should extend no more than 1/4" below material being cut. Use the depth of cut scale for standard depths.
4. Push down depth adjusting lever to lock. Check to be sure depth adjusting lever is secure.

Adjusting Miter Angle

1. Remove from battery pack
2. To adjust angle of cut, place saw on edge or workbench and pull up miter adjusting lever.
3. Hold down shoe and slide saw to desired position (up to 53°) according to markings on miter scale.
4. Push down miter lever to lock. Check angle with a square. Also check to be sure miter adjusting lever is secure before cutting.

Universal Hose Adaptor

Use the universal hose adaptor to attach the saw to a vacuum hose.

1. Remove the battery pack.
2. Remove the screw and dust chute from the upper guard.
3. Insert the vacuum hose adaptor into the upper guard and tighten the screw securely.
4. Connect the vacuum hose to the adaptor, twisting together to secure.
5. To remove, reverse the procedure.

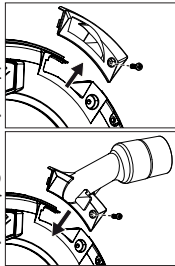

WARNING Always use either the dust chute or vacuum hose adaptor/vacuum. Failure to do so could cause dust or foreign objects to be thrown into your face or eyes which could result in possible serious injury.

OPERATION

WARNING To reduce the risk of injury, always wear proper eye protection marked to comply with ANSI Z87.1.

When working in dusty situations, wear appropriate respiratory protection or use an OSHA compliant dust extraction solution.

Keep hands away from the blade and other moving parts. Use only specifically recommended accessories. Others may be hazardous.

Kickback causes and related warnings

- Kickback is a sudden reaction to a pinched, bound or misaligned saw blade, causing an uncontrolled saw to lift up and out of the workpiece toward the operator;
- When the blade is pinched or bound tightly by the kerf closing down, the blade stalls and the motor reaction drives the unit rapidly back toward the operator;
- If the blade becomes twisted or misaligned in the cut, the teeth at the back edge of the blade can dig into the top surface of the wood causing the blade to climb out of the kerf and jump back toward the operator.

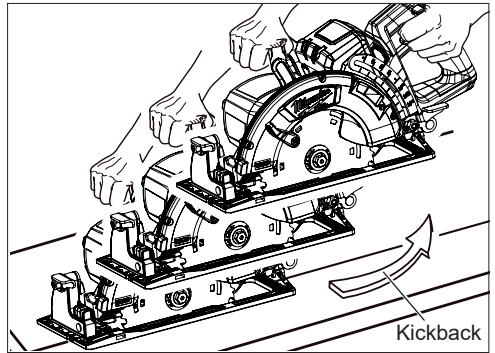

Kickback is the result of saw misuse and/or incorrect operating procedures or conditions and can be avoided by taking proper precautions as given below:

- **Maintain a firm grip with both hands on the saw and position your arms to resist kickback forces. Position your body to either side of the blade, but not in line with the blade.** Kickback could cause the saw to jump backwards, but kickback forces can be controlled by the operator, if proper precautions are taken.
- **When blade is binding, or when interrupting a cut for any reason, release the trigger and hold the saw motionless in the material until the blade comes to a complete stop. Never attempt to remove the saw from the work or pull the saw backward while the blade is in motion or kickback may occur.** Investigate and take corrective actions to eliminate the cause of blade binding.
- **When restarting a saw in the workpiece, centre the saw blade in the kerf and check that saw teeth are not engaged into the material.** If saw blade is binding, it may walk up or kickback from the workpiece as the saw is restarted.

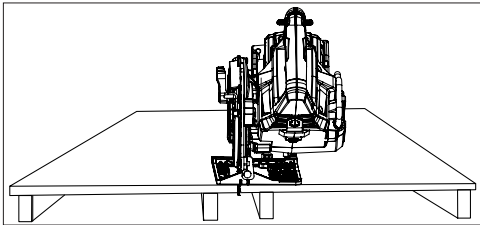
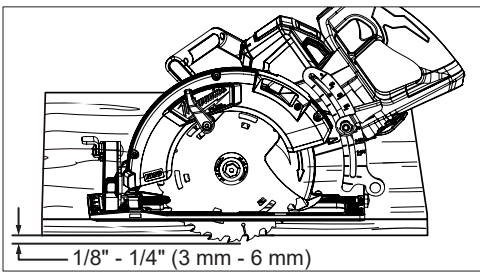

•**Support large panels to minimise the risk of blade pinching and kickback.** Large panels tend to sag under their own weight. Supports must be placed under the panel on both sides, near the line of cut and near the edge of the panel.

•**Do not use dull or damaged blades.** Unsharpened or improperly set blades produce narrow kerf causing excessive friction, blade binding and kickback.

•**Avoid overheating the blade tips and, if cutting plastics is permitted, to avoid melting the plastic.**

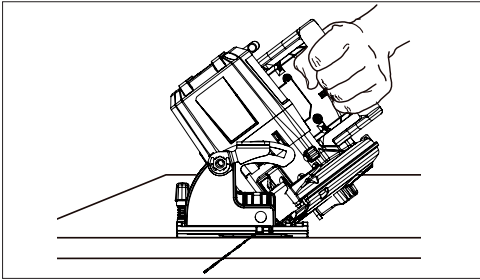

•**Blade depth and bevel adjusting locking levers must be tight and secure before making cut.** If blade adjustment shifts while cutting, it may cause binding and kickback.

•**Use extra caution when sawing into existing walls or other blind areas.** The protruding blade may cut objects that can cause kickback.

Tighten depth and miter adjusting levers securely

Set depth of cut 1/8"-1/4" greater than thickness of stock

Grip saw with both hands, keeping hands away from blade

Rest saw on larger part of workpiece, allowing smaller part to fall away

Wear safety goggles

Secure workpiece to sturdy supports

Firm footing in clean area

General Operation

Always clamp workpiece securely on a saw horse or bench. See "Applications" for the correct way to support your work in different situations. A typical application is shown below.

1. Draw cutting line. Place front of shoe on edge of workpiece without making blade contact. Hold switch handle with one hand and top handle with the other.
2. Line up sighting notch with your cutting line. Position arms and body to resist kickback. Pull trigger, allowing motor to reach full speed before beginning cut.

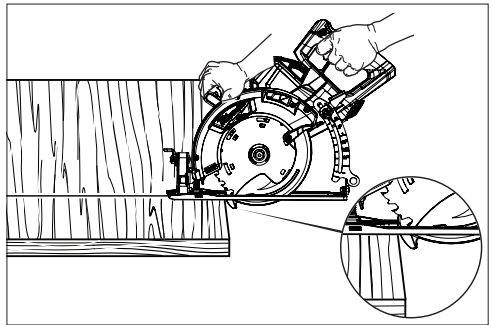

3. While cutting, keep shoe flat against workpiece and maintain a firm grip. Do not force saw through the work. Forcing a saw can cause kickback.
4. If making a partial cut, restarting in mid-cut or correcting direction, allow blade to come to a complete stop. To resume cutting, center blade in kerf, back saw away from cutting edge a few inches, pull trigger and re-enter cut slowly.
5. If saw stalls, maintain a firm grip and release trigger immediately. Correct problem before continuing (see "Preventing Kickback").
6. After finishing a cut, be sure lower guard closes and blade comes to a complete stop before setting down saw.

Troubleshooting

If blade does not want to follow straight line:

- Teeth are dull on one side. This is caused by hitting a hard object such as a nail or stone, dulling teeth on one side. The blade wants to cut to the side with the sharpest teeth.
- Shoe is out of line or bent
- Blade is bent
- Failure to use rip fence or guide

If blade binds, smokes, or turns blue from friction:

- Blade is dull
- Blade is on backwards
- Blade is bent
- Blade is dirty
- Workpiece is not properly supported
- Failure to use correct blade

APPLICATIONS

⚠WARNING To reduce the risk of electric shock, check work area for hidden pipes and wires before making plunge cuts.

Cutting Large Panels

Large panels and long boards sag or bend if they are not correctly supported. If you attempt to cut without leveling and properly supporting the piece, the blade will tend to bind, causing kickback.

Support large panels. Be sure to set the depth of cut so that you cut through workpiece only and not through the supports.

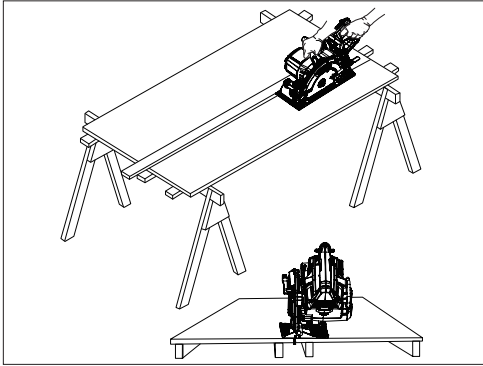

Ripping Wood

Ripping is cutting lengthwise with the grain. Select the proper blade for your job. Use a rip fence for rips 4" wide or less. To install a rip fence, slide the bar through the rip fence slot in either side of the shoe. Adjust for desired width by lining up the selected measurement with the sighting notch and lock setting with thumb screw.

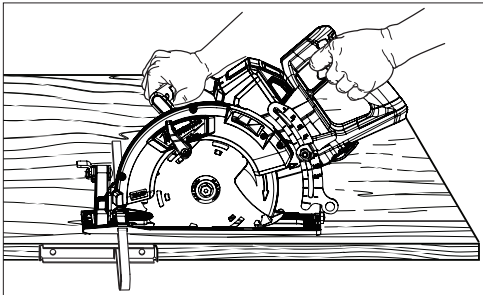

When ripping widths greater than 4", clamp or tack 1" lumber to the workpiece as a guide.

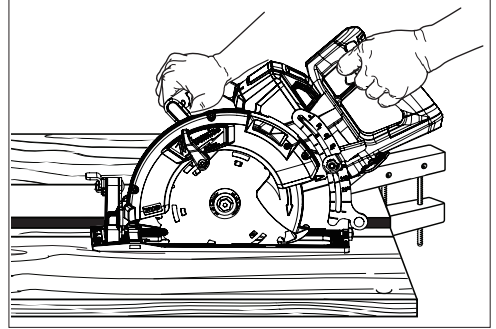

Cross-Cutting Wood

Cross-cutting is cutting across the grain. Select the proper blade for your job. Advance saw slowly to avoid the tendency of wood fibers to tear and lift.

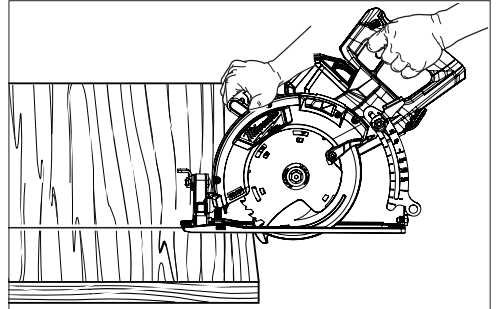

Pocket Cutting

Pocket cuts are made in the middle of the workpiece when it can not be cut from an edge. We recommend using a Sawzall® for this type of cut. However, if you must use a circular saw to make a pocket cut, USE EXTREME CAUTION.

1. Beginning at a corner, line up sighting notch with your cutting line. Tilt saw forward, firmly fixing front of shoe on workpiece. Blade should be just above cutting line, but not touching it. Raise lower guard using lower guard lever.
2. Pull trigger. Allow the blade to come to full speed. Using front of shoe as a hinge point, gradually lower back end of saw into workpiece.

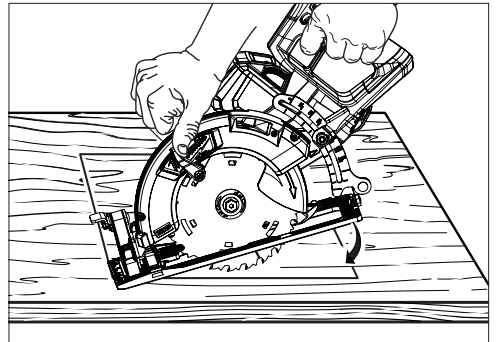

- When shoe rests flat against workpiece, move saw to far corner. Release trigger and allow blade to come to a complete stop before removing it from workpiece. Repeat the above steps for each side of the opening. Use a Sawzall[®], jig saw, or small hand saw to finish corners if they are not completely cut through.

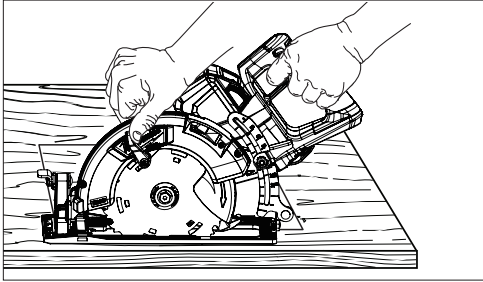

Cutting Masonry and Metal

MILWAUKEE circular saws are not intended for continuous use in cutting metal or masonry. When cutting these materials, use the correct blade. MILWAUKEE does not recommend using bonded abrasive wheels on circular saws for any application.

▲WARNING Dust, chips, and grit can cause guard to hang up at any time. If saw is used to cut masonry or metal, reserve and mark it for that purpose only and return it to a MILWAUKEE service facility for cleaning and testing before using it for wood cutting.

Only use accessories with maximum speed rating at least as high as nameplate RPM of tool.

When cutting masonry, use a diamond blade. Make successive passes at depths of less than 1/4" to achieve the desired depth. Cutting at a depth of more than 1/4" will damage wheel. Unplug the tool and frequently clean dust from air vents and guards.

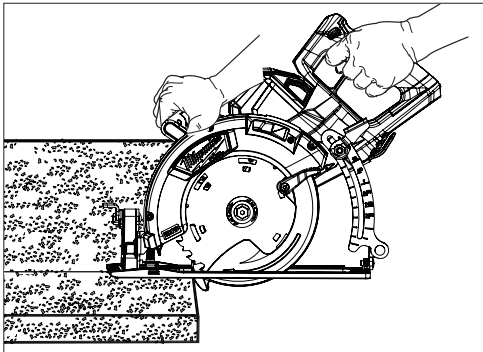

▲WARNING Do not use tool for cutting metal near flammable material. Sparks may cause fire.

When cutting metal, use a metal cutting blade. Set depth of cut to full depth. Protect everyone in the area from sparks.

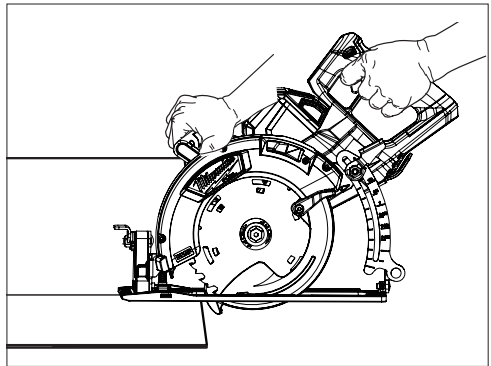

MAINTENANCE

▲WARNING To reduce the risk of injury, always unplug the charger and remove the battery pack from the charger or tool before performing any maintenance. Never disassemble the tool, battery pack or charger. Contact a MILWAUKEE service facility for ALL repairs.

Maintaining Tool

Keep your tool, battery pack and charger in good repair by adopting a regular maintenance program. Inspect your tool for issues such as undue noise, misalignment or binding of moving parts, breakage of parts, or any other condition that may affect the tool operation. Return the tool, battery pack, and charger to a MILWAUKEE service facility for repair. After six months to one year, depending on use, return the tool, battery pack and charger to a MILWAUKEE service facility for inspection.

If the tool does not start or operate at full power with a fully charged battery pack, clean the contacts on the battery pack. If the tool still does not work properly, return the tool, charger and battery pack, to a MILWAUKEE service facility for repairs.

▲WARNING To reduce the risk of personal injury and damage, never immerse your tool, battery pack or charger in liquid or allow a liquid to flow inside them.

Cleaning

Clean dust and debris from vents. Keep handles clean, dry and free of oil or grease. Use only mild soap and a damp cloth to clean, since certain cleaning agents and solvents are harmful to plastics and other insulated parts. Some of these include gasoline, turpentine, lacquer thinner, paint thinner, chlorinated cleaning solvents, ammonia and household detergents containing ammonia. Never use flammable or combustible solvents around tools.

Repairs

For repairs, return the tool, battery pack and charger to the nearest service center.

ACCESSORIES

▲WARNING Use only recommended accessories. Others may be hazardous.