



SERVICE PARTS LIST

BULLETIN NO.
54-07-2780

MAIN BODY ASSEMBLIES & ACCESSORIES

SPECIFY CATALOG NO. AND SERIAL NO. WHEN ORDERING PARTS		REVISED BULLETIN	DATE
M18™ DRAIN SNAKE WITH CABLE-DRIVE™ LOCKING FEED SYSTEM			June 2021
CATALOG NO.	2772-20	SERIAL NUMBER	H81A
WIRING INSTRUCTION			

EXAMPLE:

00
0

 Component Parts (Small #) Are Included When Ordering The Assembly (Large #).

SERVICE TABLE OF CONTENTS	
Page 1	Main Body Assemblies
Page 2	Front Handle Assemblies
Page 3	Bucket Assemblies & Cable Accessories
Page 4	Grease

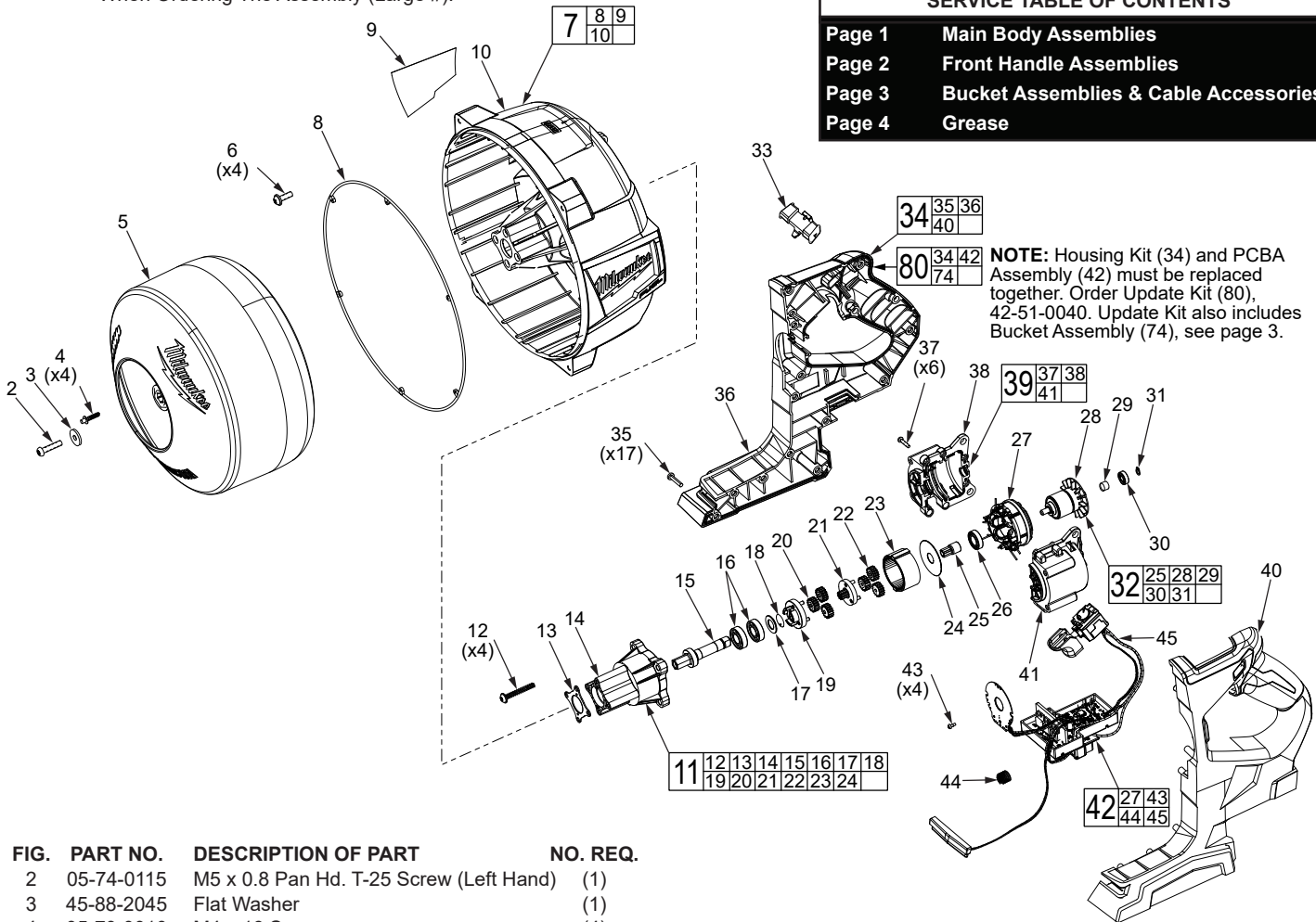

NOTE: Housing Kit (34) and PCBA Assembly (42) must be replaced together. Order Update Kit (80), 42-51-0040. Update Kit also includes Bucket Assembly (74), see page 3.

1

FIG.	PART NO.	DESCRIPTION OF PART	NO. REQ.
2	05-74-0115	M5 x 0.8 Pan Hd. T-25 Screw (Left Hand)	(1)
3	45-88-2045	Flat Washer	(1)
4	05-70-0010	M4 x 16 Screw	(4)
5	43-11-0020	Cable Drum	(1)
6	05-81-0060	M5 x 0.8 Screw	(4)
7	31-55-0012	Drum Shroud Assembly	(1)
8	43-44-0017	Seal Ring	(1)
9	12-20-0099	Service Nameplate	(1)
10	-----	Drum Shroud	(1)
11	14-30-0025	Gear Case Assembly	(1)
12	-----	M5 x 2 Screw	(4)
13	-----	Flat Washer	(1)
14	-----	Gear Case	(1)
15	-----	Output Shaft	(1)
16	-----	Ball Bearing	(2)
17	-----	Flat Washer	(1)
18	-----	Retaining Ring	(1)
19	-----	Carrier	(1)
20	-----	2nd Planet Gear	(3)
21	-----	Sun Gear	(1)
22	-----	1st Planet Gear	(3)
23	-----	Ring Gear	(1)
24	-----	Washer	(1)
25	-----	Motor Pinion	(1)
26	-----	Ball Bearing	(1)
27	-----	Motor Field	(1)
28	-----	Motor Armature	(1)

FIG.	PART NO.	DESCRIPTION OF PART	NO. REQ.
29	-----	Rear Bearing Washer	(1)
30	-----	Ball Bearing	(1)
31	-----	Retaining Ring	(1)
32	16-10-0030	Armature Assembly	(1)
33	42-42-0051	Forward/Reverse/Lock Off Shuttle	(1)
34	-----	Housing Kit	(1)
35	-----	6-19 x 11/16" Pan Hd. Taptite T15 Screw	(17)
36	-----	Right Handle	(1)
37	-----	Screw	(6)
38	-----	Right Motor Cage	(1)
39	14-50-0033	Motor Field Assembly	(1)
40	-----	Left Handle	(1)
41	-----	Left Motor Cage	(1)
42	22-74-0026	PCBA Assembly	(1)
43	-----	M2 x 1 Screw	(4)
44	-----	Latch Spring	(1)
45	-----	PCBA	(1)
80	42-51-0040	Update Kit	(1)

FRONT HANDLE ASSEMBLIES

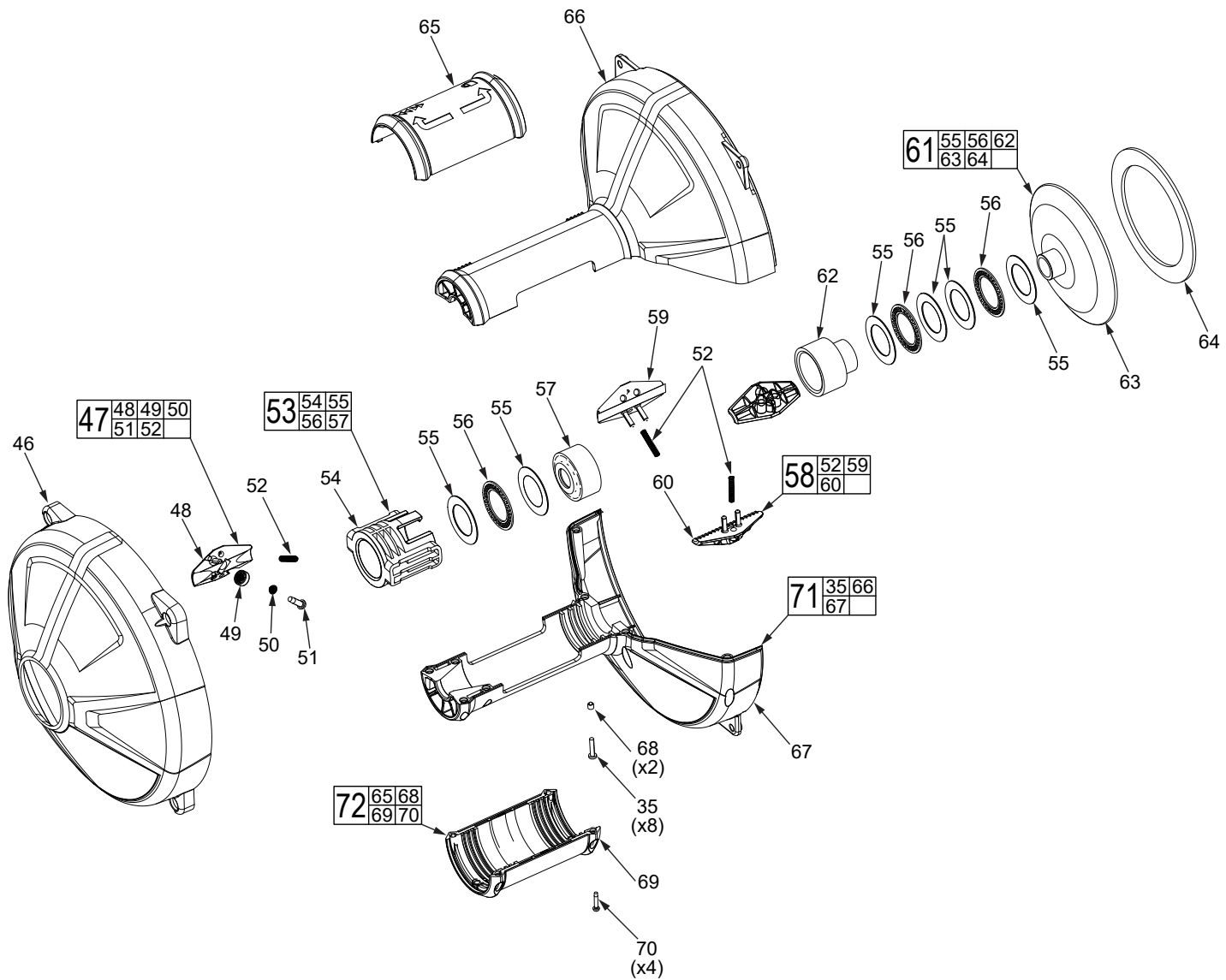
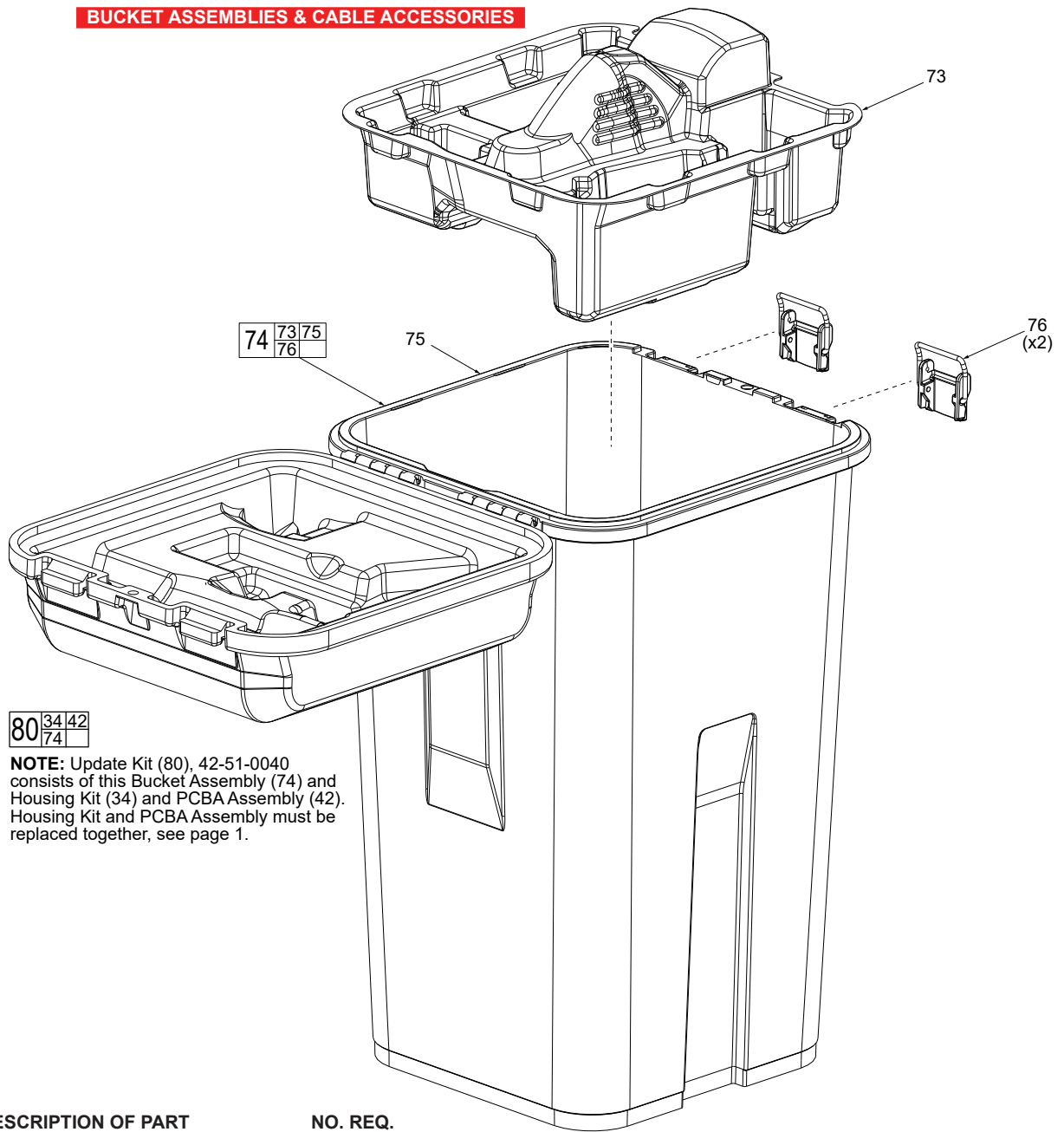

FIG.	PART NO.	DESCRIPTION OF PART	NO. REQ.
	35	6-19 x 11/16" Pan Hd. Taptite T15 Screw	(8)
	46	43-86-0016 Rubber Boot	(1)
	47	42-77-0075 Collet Kit (Set of 3)	(1)
	48	Collet	(3)
	49	Ball Bearing	(3)
	50	Flat Washer	(3)
	51	8-16 x 5/8" Pan Hd. ST T20 Screw	(3)
	52	Spring	(6)
	53	31-15-0056 Lock Slide Assembly	(1)
	54	Lock Slide	(1)
	55	Flat Washer	(6)
	56	Bearing	(3)
	57	Lock Slide Ramp	(1)
	58	42-77-0080 Lock Collet Kit	(1)
	59	Flat Spring Lock Collet	(1)

FIG.	PART NO.	DESCRIPTION OF PART	NO. REQ.
	60	Lock Collet	(2)
	61	42-77-0085 Cable Funnel Assembly	(1)
	62	Lock Collet Ramp	(1)
	63	Cable Funnel	(1)
	64	Gasket	(1)
	65	Twist Lock Upper Handle	(1)
	66	Left Shroud Cover	(1)
	67	Right Shroud Cover w/ Cover Seal	(1)
	68	Nut	(2)
	69	Twist Lock Lower Handle	(1)
	70	M3 x 16 Screw	(4)
	71	31-15-0070 Shroud Cover Kit	(1)
	72	31-15-0066 Twist Lock Kit	(1)

BUCKET ASSEMBLIES & CABLE ACCESSORIES



80 $\frac{34}{74}$ $\frac{42}{74}$

NOTE: Update Kit (80), 42-51-0040 consists of this Bucket Assembly (74) and Housing Kit (34) and PCBA Assembly (42). Housing Kit and PCBA Assembly must be replaced together, see page 1.

FIG.	PART NO.	DESCRIPTION OF PART	NO. REQ.
	73	Top Bucket Tray	(1)
	74	Bucket Assembly	(1)
	75	Bucket	(1)
	76	44-20-1015 Latch	(2)
	80	42-51-0040 Update Kit	(1)

Cables & Attachment Head Accessories

--	48-53-2561	5/16" x 25' Inner Core Rust Resistant Bulb Head Cable	--	48-53-2673	5/16" x 35' Inner Core Rust Resistant Bulb Head Cable
--	48-53-2562	5/16" x 25' Inner Core Rust Resistant Drop Head Cable	--	48-53-2674	5/16" x 50' Inner Core Rust Resistant Bulb Head Cable
--	48-53-2563	1/4" x 25' Inner Core Rust Resistant Bulb Head Cable	--	48-53-2675	3/8" x 35' Inner Core Rust Resistant Coupling Cable
--	48-53-2564	1/4" x 25' Inner Core Rust Resistant Drop Head Cable	--	48-53-2676	3/8" x 25' Inner Core Rust Resistant Coupling Cable
--	48-53-2571	5/16" x 25' Inner Core Bulb Head Cable	--	48-53-2681	Small Bulb Head
--	48-53-2572	5/16" x 25' Inner Core Drop Head Cable	--	48-53-2682	Small Drop Head
--	48-53-2573	1/4" x 25' Inner Core Bulb Head Cable	--	48-53-2683	1" Spade Bit
--	48-53-2574	1/4" x 25' Inner Core Drop Head Cable	--	48-53-2684	1" C-Cutter
--	48-53-2671	1/4" x 35' Inner Core Rust Resistant Bulb Head Cable	--	48-53-2685	5 pc. Small Drain Line Kit
--	48-53-2672	1/4" x 50' Inner Core Rust Resistant Bulb Head Cable			

NOTE

Regarding parts to be lubricated:
Apply a light coating of Type "J" grease (49-08-4220)
to all highlighted parts shown prior to installation.

