



SERVICE PARTS LIST

BULLETIN NO.
54-00-2746

SPECIFY CATALOG NO. AND SERIAL NO. WHEN ORDERING PARTS		REVISED BULLETIN	DATE
M18™ FUEL™ 18 Ga. Finish Nailer			Nov. 2019
CATALOG NUMBER	2746-20	SERIAL NUMBER	K46A
WIRING INSTRUCTION			

AVAILABLE SERVICE PARTS **PAGE 2**

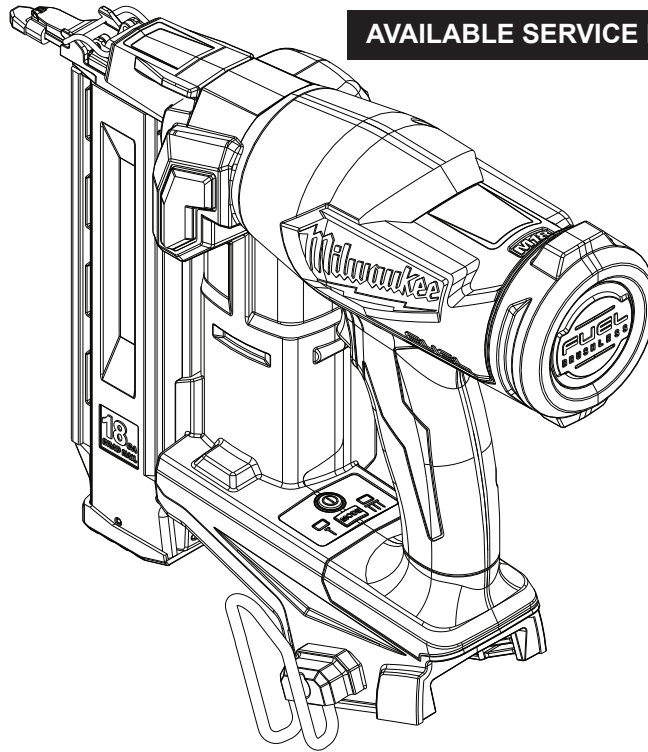

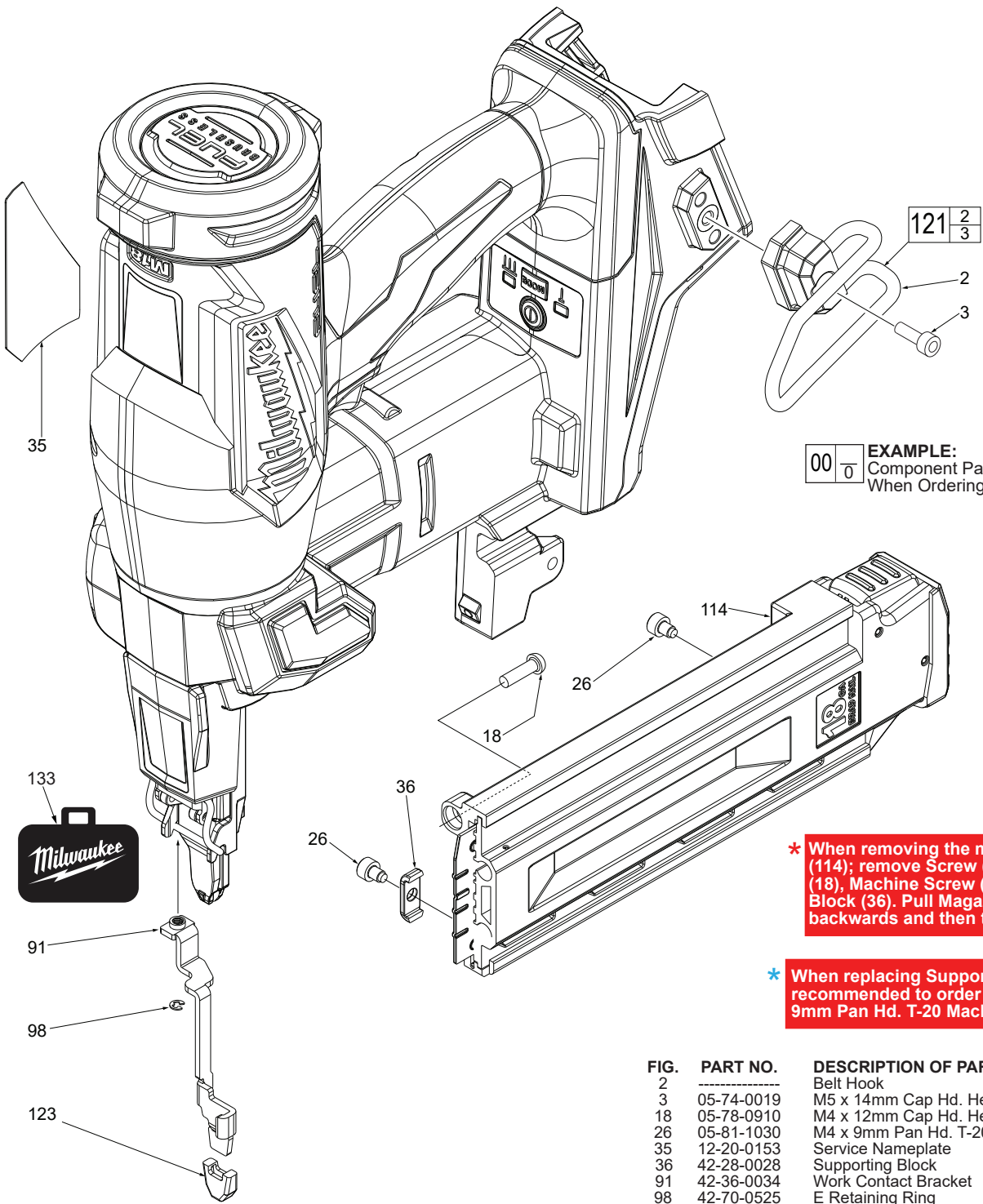

EXAMPLE:
Component Parts (Small #) Are Included
When Ordering The Assembly (Large #).

* When removing the magazine assembly (114); remove Screw (26), Hex Socket Screw (18), Machine Screw (78) and Supporting Block (36). Pull Magazine Assembly (114) backwards and then twist.

* When replacing Support Block (36) it is recommended to order the following: M4 x 9mm Pan Hd. T-20 Machine Screw (26) qty 1.

FIG.	PART NO.	DESCRIPTION OF PART	NO. REQ.
2	-----	Belt Hook	(1)
3	05-74-0019	M5 x 14mm Cap Hd. Hex Socket Screw	(1)
18	05-78-0910	M4 x 12mm Cap Hd. Hex Socket Screw	(3)
26	05-81-1030	M4 x 9mm Pan Hd. T-20 Machine Screw	(2)
35	12-20-0153	Service Nameplate	(1)
36	42-28-0028	Supporting Block	(1)
91	42-36-0034	Work Contact Bracket	(1)
98	42-70-0525	E Retaining Ring	(1)
114	43-40-0014	Magazine Assembly	(1)
121	42-70-0021	Belt Clip Assembly	(1)
123	42-38-0017	No-Mar Pad Kit (Set of 3)	(1)
126	10-20-3069	Warning Label (Not Shown)	(1)
133	42-55-6150	Contractor Bag	(1)