



SERVICE PARTS LIST

BULLETIN NO.
54-40-2800

SPECIFY CATALOG NO. AND SERIAL NO. WHEN ORDERING PARTS		REVISED BULLETIN	DATE
M18™ FUEL JIG SAW (D-Handle)			
CATALOG NO.	2737-20	STARTING SERIAL NO.	J70A
		WIRING INSTRUCTION SEE PAGE 3	

EXAMPLE:
Component Parts (Small #)
Are Included When Ordering
The Assembly (Large #).

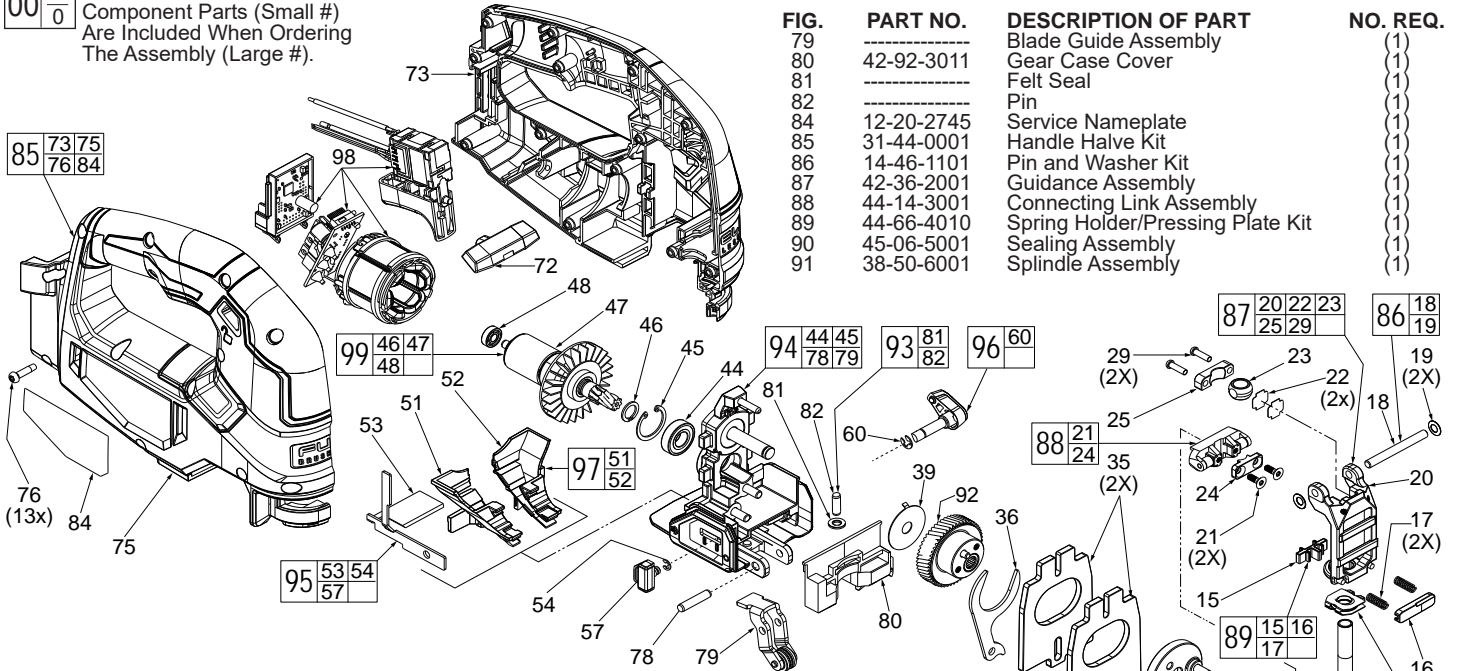
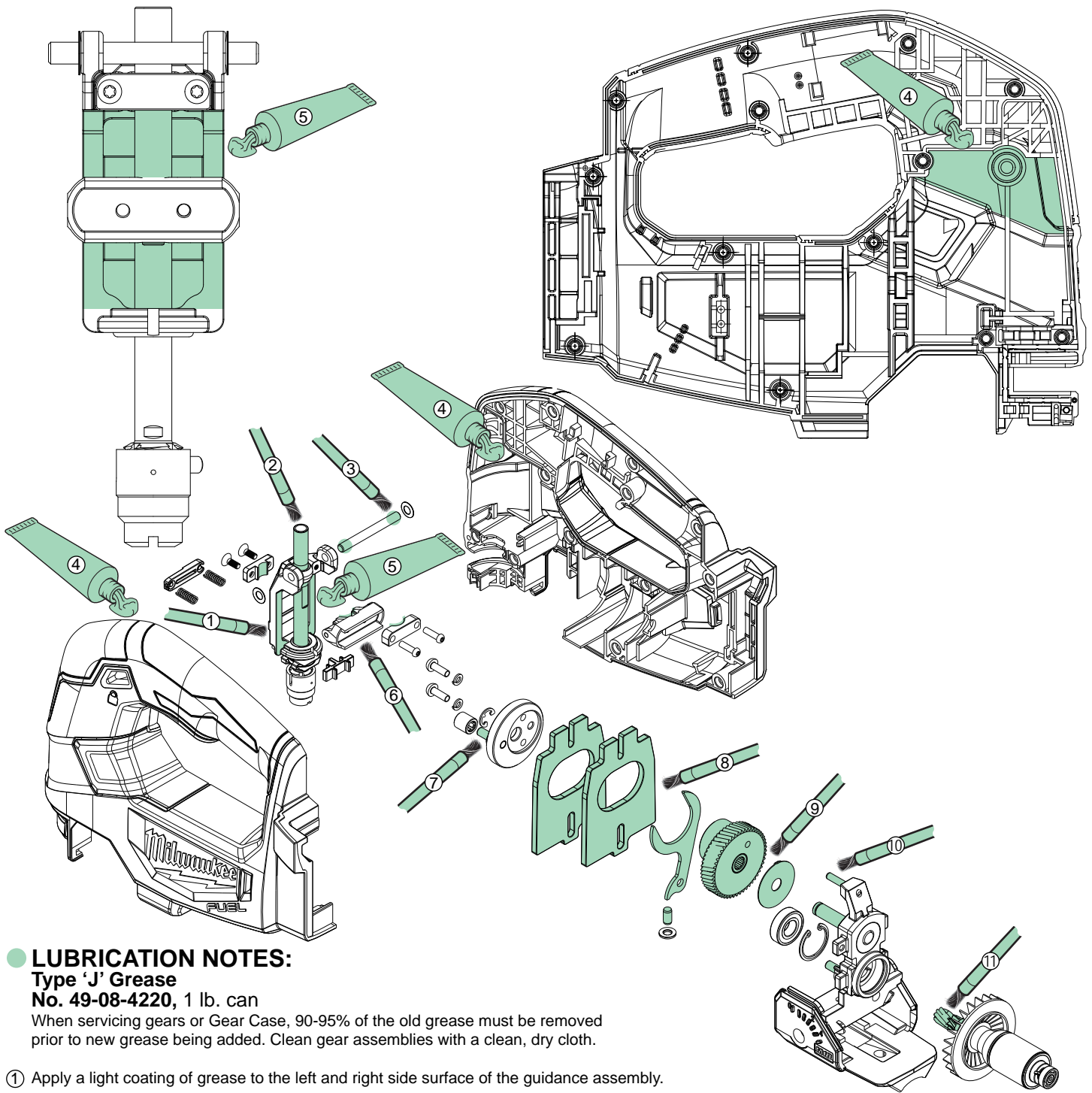

FIG.	PART NO.	DESCRIPTION OF PART	NO. REQ.
1	42-92-4001	Blade Cover	(1)
2	43-54-4001	Guard Wire	(1)
3	44-10-5001	Rotation Lever	(1)
4	40-50-1001	Spring	(1)
15	-----	Pressing Plate	(1)
16	-----	Spring Holder	(1)
17	-----	Spring	(2)
18	-----	Pin	(1)
19	-----	Disc Springs	(2)
20	-----	Spindle Guide	(1)
21	-----	M3.5 x 10mm Flat Hd. T-15 Mach. Scr.	(2)
22	-----	Leaf Spring	(2)
23	-----	Sliding Bearing	(1)
24	-----	Link Cover	(1)
25	-----	Cover	(1)
29	05-88-5380	M3.5 x 12mm Pan Hd. T-10 Mach. Scr.	(2)
30	34-60-4001	E-Retaining Ring	(1)
31	05-81-1070	M4 x 12mm Pan Hd. T-20 Mach. Screw	(2)
32	02-50-1260	Needle Bearing	(1)
33	45-88-1890	Spring Washer	(3)
34	44-66-1510	Eccentricity Plate	(1)
35	42-28-2001	Balance Block	(2)
36	44-66-1630	Drive Plate	(1)
39	45-88-3070	Washer	(1)
44	-----	Ball Bearing	(1)
45	-----	C-Retaining Ring	(1)
46	-----	Retaining Ring	(1)
47	-----	Rotor	(1)
48	-----	Ball Bearing	(1)
51	-----	Right Air Channel	(1)
52	-----	Left Air Channel	(1)
53	-----	Blower Shuttle	(1)
54	34-60-0401	E-Retaining Ring	(1)
57	-----	Blower Shut Off Button	(1)
60	34-60-0770	E-Retaining Ring	(1)
61	44-10-6001	Adjustable Base Lever	(1)
62	28-06-6001	Base	(1)
63	31-17-0570	Base Clamp	(1)
64	45-88-2060	Washer	(1)
65	05-74-1001	M6 Screw Bolt	(1)
66	05-81-1033	M4 x 9mm T-20 Screw	(1)
67	42-92-2001	Base Insert	(1)
68	05-81-1050	M4 x 10mm Flat Head T-20 Screw	(4)
69	31-15-0693	Base Cover	(1)
70	31-03-5001	Vacuum Attachment	(1)
72	42-42-8001	Lock Button	(1)
73	-----	Left Housing Halve - Support	(1)
74	05-88-1208	M4 x 13mm Flat Head T-20 Screw	(2)
75	-----	Right Housing Halve - Cover	(1)
76	05-88-1200	M4 x 16mm Pan Hd. ST T-20 Screw	(13)
77	43-84-1030	Anti-Splintering Insert	(1)
78	-----	Pin	(1)

FIG.	PART NO.	DESCRIPTION OF PART	NO. REQ.
79	-----	Blade Guide Assembly	(1)
80	42-92-3011	Gear Case Cover	(1)
81	-----	Felt Seal	(1)
82	-----	Pin	(1)
84	12-20-2745	Service Nameplate	(1)
85	31-44-0001	Handle Halve Kit	(1)
86	14-46-1101	Pin and Washer Kit	(1)
87	42-36-2001	Guidance Assembly	(1)
88	44-14-3001	Connecting Link Assembly	(1)
89	44-66-4010	Spring Holder/Pressing Plate Kit	(1)
90	45-06-5001	Sealing Assembly	(1)
91	38-50-6001	Spindle Assembly	(1)
92	32-30-8001	Output Gear Assembly	(1)
93	14-46-7001	Orbit Pin and Seal Kit	(1)
94	28-14-8001	Gear Case Assembly	(1)
95	42-14-9001	Blower Assembly	(1)
96	30-58-0001	Orbit Adjustment Lever Assembly	(1)
97	43-56-1001	Channel Kit	(1)
98	14-20-9001	Electronic Assembly	(1)
99	16-01-0001	Rotor Assembly	(1)
100	42-55-0007	Blow Molded Carrying Case	(1)
101	45-96-8001	Wrench	(1)
102	10-20-5472	Warning Label (Not Shown)	(1)
103	40-50-2737	Spring Plate	(2)





● LUBRICATION NOTES:

Type 'J' Grease

No. 49-08-4220, 1 lb. can

When servicing gears or Gear Case, 90-95% of the old grease must be removed prior to new grease being added. Clean gear assemblies with a clean, dry cloth.

- ① Apply a light coating of grease to the left and right side surface of the guidance assembly.
- ② Brush a light coating of grease to the entire shaft of spindle assembly.
- ③ Apply a light coating of grease to both ends of pin.
- ④ Place 2 grams (4 grams total) into each front cavity of housing support and housing cover.
- ⑤ Place approximately 9 grams of grease over and around spindle of guidance assembly.
- ⑥ Lightly coat concave surface of link cover and connecting link assembly.
- ⑦ Lightly coat surface of pin on the eccentricity plate with grease .
- ⑧ Brush a thin coat of grease to the entire surface of both balance blocks and drive plate.
- ⑨ Completely coat the output gear assembly with grease, being sure to cover all gear teeth. Lightly cover the washer with grease.
- ⑩ Brush all four pins of the gear case assembly with a light coating of grease.
- ⑪ Brush grease on the rotor pinion being sure to cover all the teeth.



Route LED leads through these wire traps and channels prior to installing the On-Off Switch.

As an aid to reassembly, take notice of wire routings and position in wire guides and traps while dismantling tool. Route wires into wire traps and channels as shown.

Be sure to place wires down into wire traps, being sure to remove any wire slack while routing.

Be sure all components of electronics assembly are seated firmly and squarely in the corresponding cavity of handle support.

Be sure there are no interferences when installing handle cover over handle support. Watch for pinched wires.

Check for proper functionality of slide buttons and speed dial prior to installing battery.

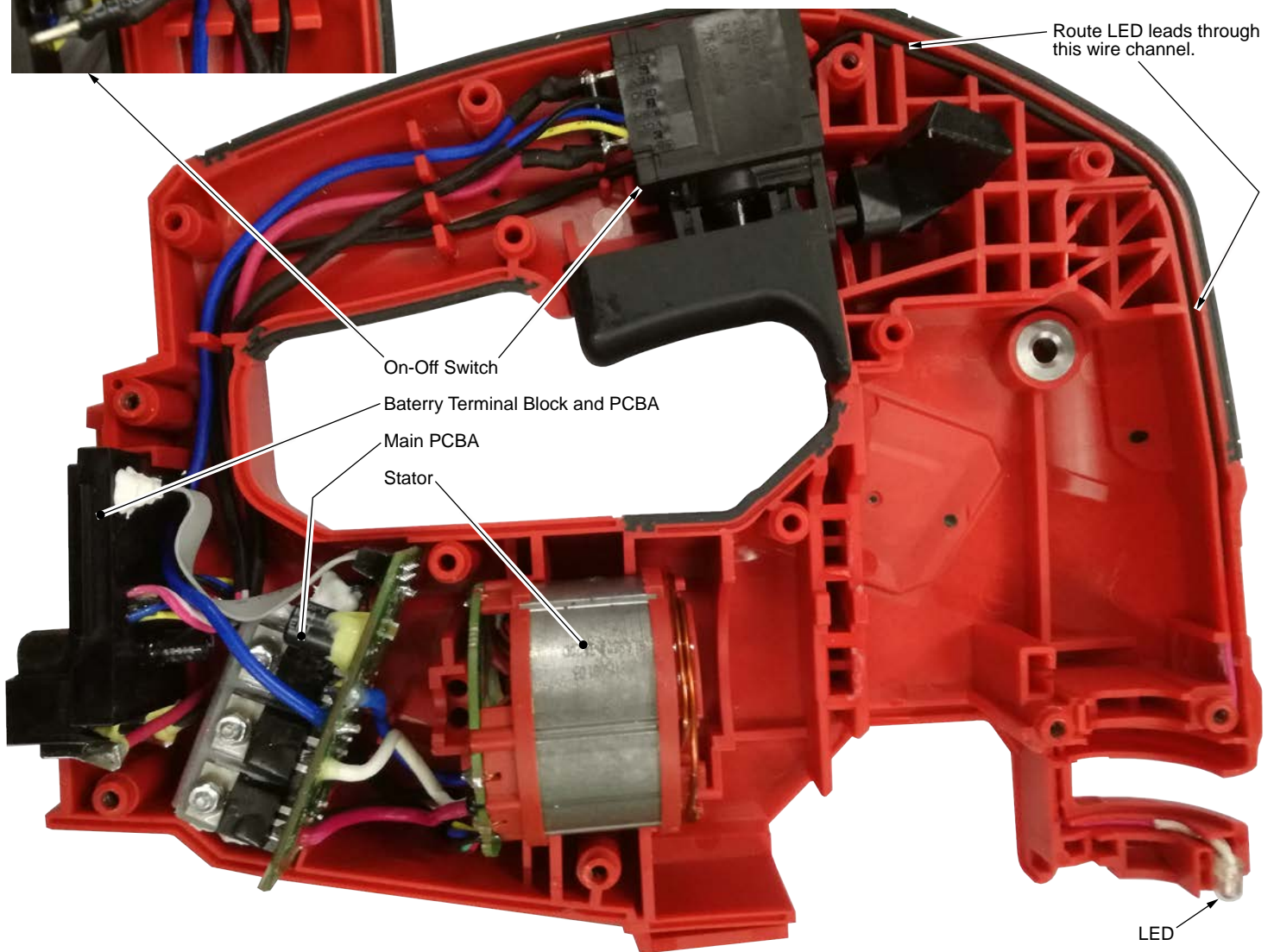

Route LED leads through this wire channel.

On-Off Switch

Battery Terminal Block and PCBA

Main PCBA

Stator

LED