



SERVICE PARTS LIST

BULLETIN NO.
54-40-2615

SPECIFY CATALOG NO. AND SERIAL NO. WHEN ORDERING PARTS		REVISED BULLETIN	DATE
M18™ Hackzall®		54-40-2614	May 2019
CATALOG NO.	2625-20	WIRING INSTRUCTION SEE PAGE 3	
	STARTING SERIAL NO.	C41F	

FIG.	PART NO.	DESCRIPTION OF PART	NO. REQ.
1	45-16-0925	Shoe	(1)
2	34-60-3680	Retaining Ring	(1)
3	42-50-0076	Front Cam	(1)
4	42-50-0077	Rear Cam	(1)
5	44-60-0626	Lock Pin	(1)
6	45-22-0081	Sleeve	(1)
7	40-50-0161	Torsion Spring	(1)
8	31-15-0511	Spring Cover	(1)
9	44-86-0740	Front Cap	(1)
10	45-06-0880	Felt Seal	(1)
12	38-50-0411	Spindle and Bushing Kit	(1)
14	05-88-1712	M3.5 x 22 Pan Hd. Plastite T-15 Screw	(8)
15	06-82-2395	M2.6 x 10 Pan Hd. Plastite T-8 Screw	(1)
16	05-88-1610	M3.5 x 10 Pan Hd. Plastite T-10 Screw	(1)

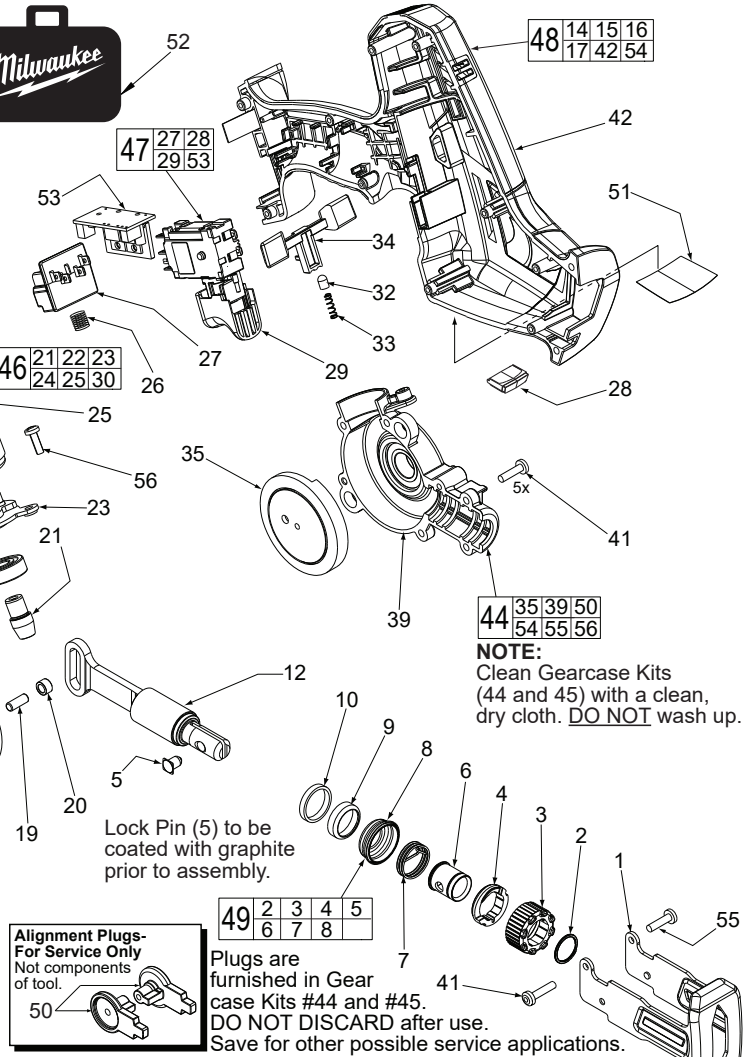
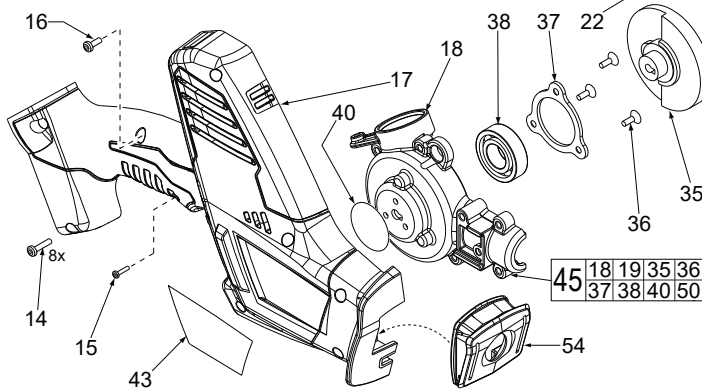
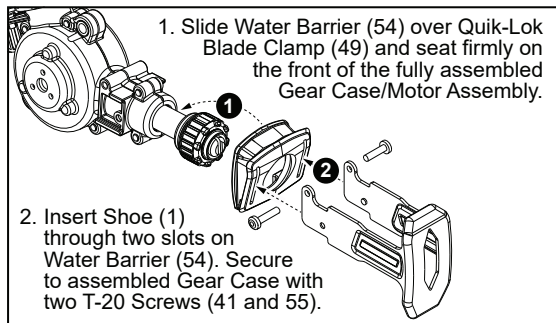

FIG.	PART NO.	DESCRIPTION OF PART	NO. REQ.
17	-----	Handle Halve - Right	(1)
18	-----	Gearcase Support - Right Halve	(1)
19	-----	Drive Pin	(1)
20	44-86-0800	Drive Pin Sleeve	(1)
21	-----	Spiral Bevel Pinion	(1)
22	-----	Ball Bearing	(1)
23	-----	Motor Mount Plate	(1)
24	-----	Shoulder Pin	(2)
25	-----	Motor	(1)
26	40-50-1090	Terminal Block Spring	(1)
27	-----	Terminal Block	(1)
28	-----	LED Assembly	(1)
29	-----	Switch	(1)
30	-----	Set Screws	(2)
★ 31	06-82-2380	8-32 x 1/2" Pan Hd. Taptite T-20 Screw	(1)
32	43-72-0430	Detent Holder	(1)
33	40-50-1475	Detent Spring	(1)
34	45-24-0680	Locking Shuttle	(1)
35	-----	Spiral Bevel Gear	(2)
★ 36	-----	Bearing Plate Screws	(3)
★ 37	-----	Bearing Plate	(1)
★ 38	-----	Ball Bearing	(1)
39	-----	Gearcase Cover- Left Halve	(1)
40	23-70-3350	Aluminum Tape	(1)
★ 41	06-82-5320	8-32 x 5/8" Pan Hd. Tapt. T-20 Screw	(6)
42	-----	Handle Halve - Left	(1)
43	12-20-2625	Service Nameplate	(1)
★ 44	14-30-1051	Gearcase Cover Kit - Left Halve	(1)
45	14-30-1031	Gearcase Support Kit - Right Halve	(1)
46	23-30-0901	Motor Assembly Kit	(1)
47	23-66-2977	Switch Kit	(1)

FIG.	PART NO.	DESCRIPTION OF PART	NO. REQ.
48	31-44-2499	Handle Kit	(1)
49	14-46-1011	Steel Quik-Lok® Blade Clamp Kit	(1)
★ 50	44-68-0021	Alignment Plug - Service Tool (Not component of tool - one per in kits 44 & 45)	(1)
51	10-15-1090	Warning Label	(1)
52	48-55-3500	Contractor Tool Bag	(1)
53	-----	VASMO PCBA	(1)
★ 54	45-06-0017	Water Barrier	(1)
★ 55	05-88-1200	M4 x 16mm Pan Hd. ST T-20 Screw	(1)
★ 56	06-82-1020	M4 x 14mm Pan Hd. ST T-20 Screw	(1)

FIG. LUBRICATION (Type 'L' Grease, No. 49-08-4175):

9,10 Saturate Felt (10) with lightweight oil prior to assembly with Cap (9) onto Bushing (11) and Spindle (12).

11,12 Lightly coat the O.D. of Spindle Shaft (12) and I.D. of Bushing (11) with grease.

12 Place a dab of grease in the rear slot of Spindle Shaft (12).

18,39 Place .25 ounce grease in gear cavity of Gearcases (18,39). Coat the spindle shaft pocket in Gearcases (18,39).

19,20 Lightly coat the Drive Pin (19) and I.D. and O.D. of Bearing Sleeve (20) with grease.

21,35 Completely coat all of the teeth of the Spiral Bevel Pinion (21) and Spiral Bevel Bevel Gears (35) with grease.

Picture 'A'

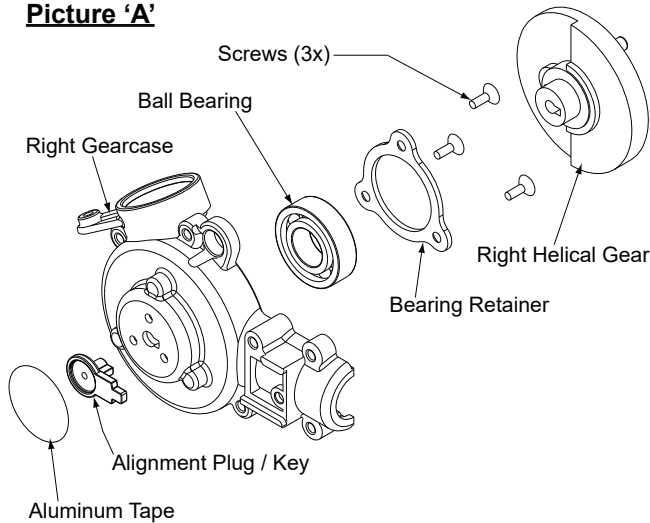

Components of **Right Gearcase Kit #14-30-1031**

Picture 'B'

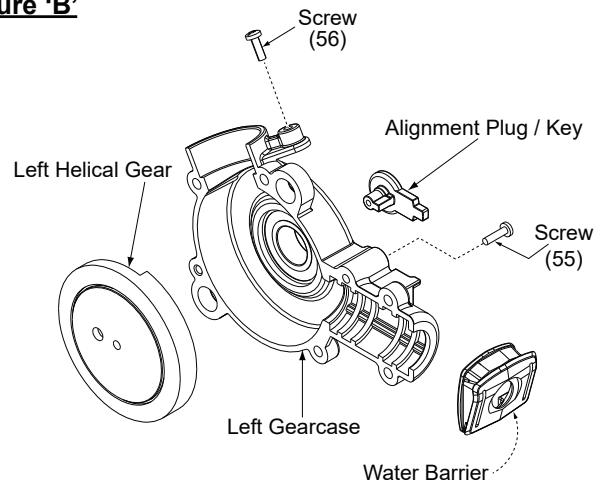

Components of **Left Gearcase Kit #14-30-1051**

Picture "A and B" show the components that make-up the Right and Left Gearcase kits for M18 Cordless Hackzall 2625-20. Each kit contains one [1] Alignment Plug / Key. The right gearcase kit has an aluminum adhesive backed disc (not sold separately) which will be needed when servicing / replacing the right gearcase assembly.

The Right and Left helical gear assemblies are supported independently in their respective gearcase assembly and turn independently. Each of the helical gears have a counter weight and when the two gearcase halves are assembled together **gearing must be synchronized to eliminate excessive vibration.**

Synchronization of the two gear case halves can be accomplished by using the Alignment Plug / Key supplied with each gearcase kit. Anytime motor assembly 23-30-0901 has to be removed from the gearcase halves, helical gears will need to be resynchronized using the alignment plug / keys.

Synchronizing / Assembling Gearcase Kit Assemblies 14-30-1031 – 14-30-1051

Once the **motor assembly** has been removed from the gearcase assembly the keyway cut into each **helical gear** will no longer be aligned with the **gearcase keyway** (fig. 1) due to the counter balance of the helical gear.

1. Rotate (by hand) **helical gear** in right gearcase (picture "A") until **helical gear keyway** is in-line with the **gearcase keyway** (fig. 2).
2. Install **plug / key** from kit into gearcase / helical gear keyway (fig. 3).
3. Install **drive pin sleeve** onto pin located on right helical gear (coat with type "L" grease).

4. Install **spindle / gearcase bushing assembly** into right gearcase (coat components with type "L" grease and make sure spindle lock pin hole faces right gearcase).
Note: If new felt seal is being installed saturate seal with a lightweight oil.
5. Place approximately 1/8oz. Type "L" grease onto teeth of right helical gear. (Set assembly aside).
6. Rotate (by hand) **helical gear** in left gearcase (picture "B") until **helical gear keyway** is in-line with the **gearcase keyway** (fig. 2).
7. Install **plug / key** from kit into gearcase / helical gear keyway (fig. 3).
8. Place approximately 1/8oz. Type "L" grease onto teeth of left helical gear.
9. Assemble lubricated left gearcase assembly onto lubricated right gearcase assembly and install five [5] gearcase screws.
10. Install motor assembly 23-30-0901 and secure to gearcase assembly.
11. Remove left and right alignment plug (s) and apply aluminum tape disc from kit to the right of gearcase (fig.4). **SAVE PLUGS** incase motor needs servicing or replacing.

FIG. 1

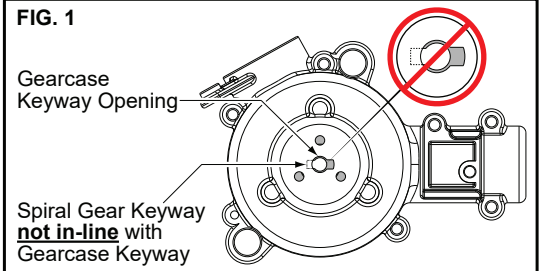
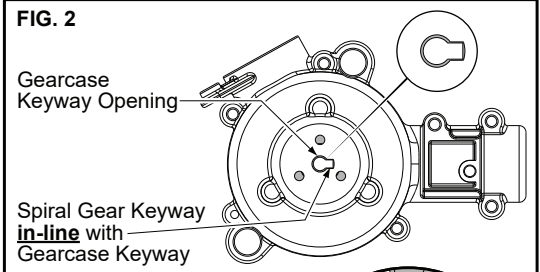

FIG. 2



Alignment Plug / Key installed in Gearcase

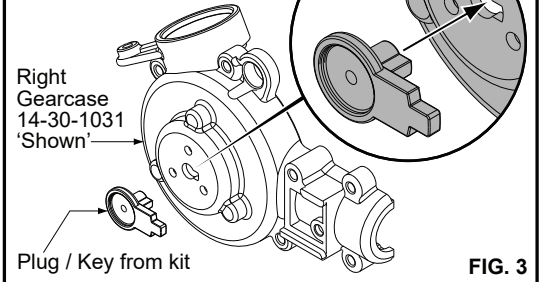

FIG. 3

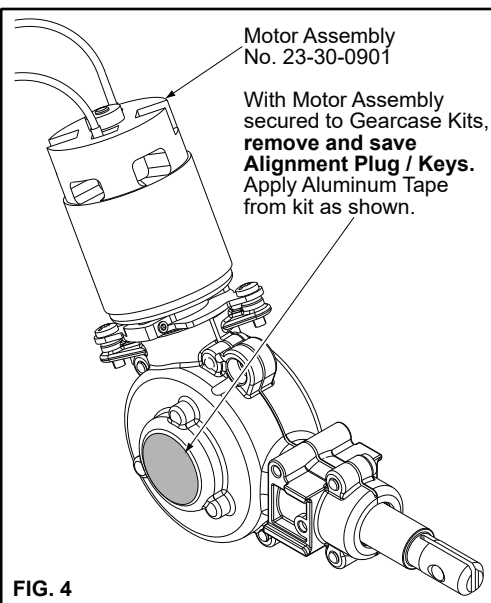

FIG. 4

REMOVING THE STEEL QUIK-LOK® BLADE CLAMP (49)

- Remove external retaining ring (2) and pull front cam (3) off.
- Pull lock pin (5) out and remove remainder of parts and discard.

REASSEMBLY OF THE STEEL QUIK-LOK® BLADE CLAMP (49)

- Coat new lock pin with powdered graphite.
- Hold tool in a vertical position.
- Place spring cover (8) onto spindle.
- Slide torsion spring (7) onto spindle with spring leg on hole side of spindle.
- Slide sleeve (6) onto spindle aligning hole on sleeve with hole in spindle.
- Slide rear cam (4) over sleeve (6) until it bottoms on sleeve shoulder, ensure leg of spring (7) inserts into outer slot in rear cam (4).
- Rotate rear cam in the direction of the arrows located on spring cover until there is clearance for lock pin (5) to be inserted into sleeve/spindle holes. Insert lock pin.
- Align front cam (3) inner ribs with rear cam outer slots and slide front cam onto sleeve until it bottoms. Retaining ring groove on the spindle shaft (12) should be completely visible.
- Attach retaining ring (2) by separating coils and inserting end of ring into groove, then wind remainder of ring into groove. Ensure ring is seated in groove.
- Blade clamp should rotate freely. During normal usage, debris may not allow blade clamp to rotate freely. The use of spray lubricant can help free blade clamp. In extreme conditions, follow these instructions to remove, clean and reassemble blade clamp.

