



SERVICE PARTS LIST

BULLETIN NO.
54-47-0460

SPECIFY CATALOG NO. AND SERIAL NO. WHEN ORDERING PARTS		REVISED BULLETIN
M12™ FUEL 1/2" RATCHET		
CATALOG NO.	2558-20	SERIAL NUMBER J20A
		WIRING INSTRUCTION See Pages 2 and 3

EXAMPLE:
Component Parts
(Small #) Are Included
When Ordering Assy.
(Large #).

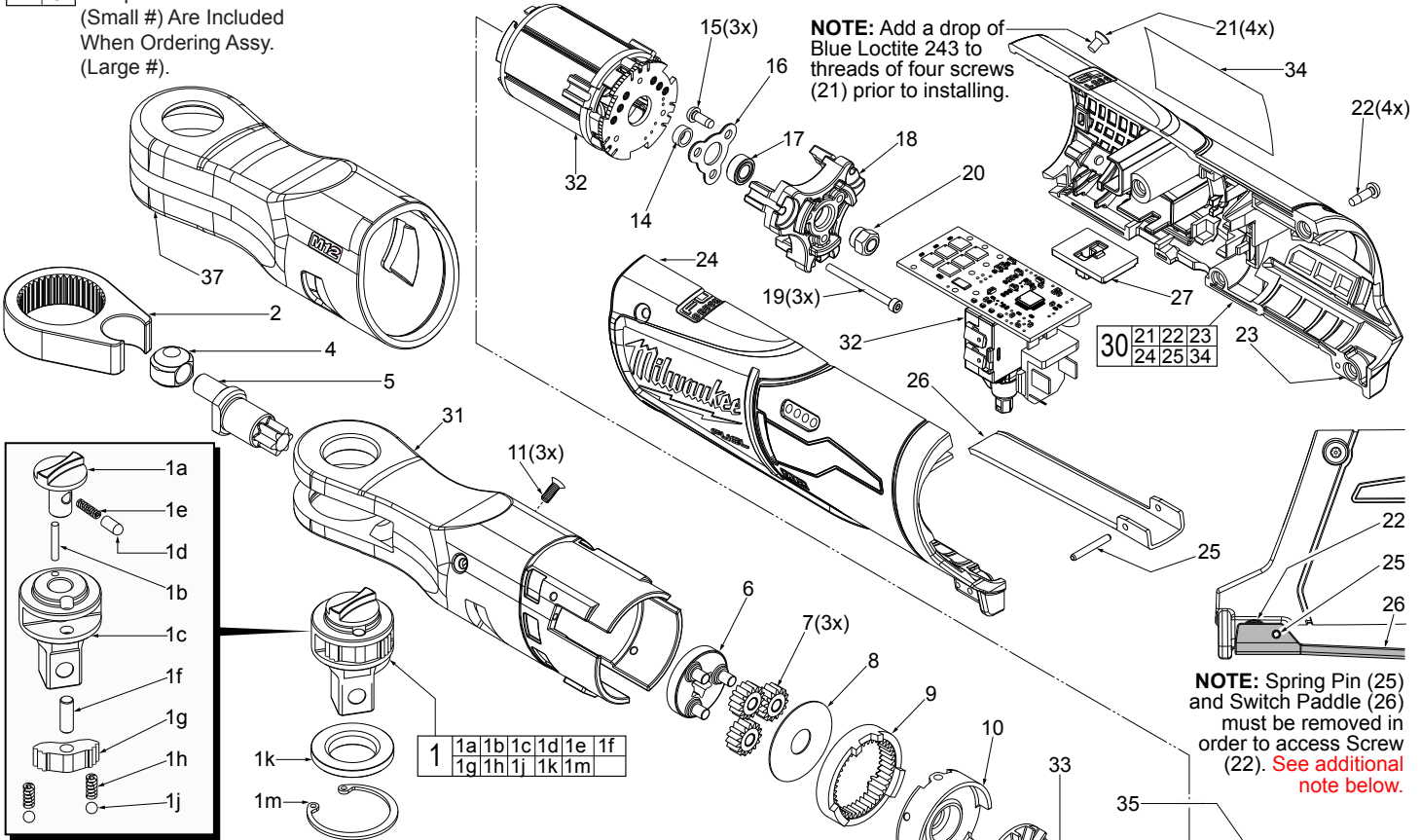

FIG.	PART NO.	DESCRIPTION OF PART	NO. REQ.
1	42-06-2558	1/2" Anvil Service Kit	(1)
1a	-----	Forward/Reverse Knob	(1)
1b	-----	Roll Pin	(1)
1c	-----	1/2" Anvil	(1)
1d	-----	Cap	(1)
1e	-----	Spring	(1)
1f	-----	Pawl Pin	(1)
1g	-----	Pawl	(1)
1h	-----	Spring	(2)
1j	-----	Steel Ball	(2)
1k	-----	Friction Plate	(1)
1m	-----	Retaining Ring	(1)
2	45-98-0065	Yoke (for 3/8" and 1/2" ratchet)	(1)
4	42-40-0985	Bushing (for 3/8" and 1/2" ratchet)	(1)
5	36-17-0405	Crank Shaft (for 3/8" and 1/2" ratchet)	(1)
6	28-23-1005	Carrier Assembly (for 3/8" & 1/2" ratchet)	(1)
7	32-62-0615	Planet Gear (for 3/8" & 1/2" ratchet)	(3)
8	45-88-2035	Washer	(1)
9	32-65-0405	Ring Gear (for 3/8" & 1/2" ratchet)	(1)
10	44-66-0047	Motor Holder	(1)
11	05-81-0105	M3 x 10mm Flat Hd. Machine T-10 Screw	(3)
14	42-40-0210	Bushing	(1)
15	06-82-2310	M3 x 8mm Pan Hd. Tapt. T-10 Screw	(3)
16	44-86-1405	Bearing Plate	(1)
17	02-04-0303	Ball Bearing	(1)
18	44-66-1008	Motor Plate	(1)
19	05-84-0200	M2.5 x 31mm Socket Hd. Hex Drive Scr.	(3)
20	05-55-0047	Hex Nut	(1)
21	05-81-0592	M4 x 6mm Flat Hd. T-15 Machine Screw	(4)
22	06-82-3002	M3 x 10mm Pan Hd. Tapt. T-10 Screw	(4)
23	-----	Housing Cover - Right Housing Halve	(1)
24	-----	Housing Support - Left Housing Halve	(1)
25	44-60-0575	Spring Pin	(1)
26	44-10-0740	Switch Paddle	(1)
27	42-42-0033	Switch Lock-Out	(1)
30	31-44-0522	Housing Kit	(1)
31	14-46-0482	1/2" Yoke Housing Assembly	(1)
32	14-20-0112	Electronics Assembly (for 1/2" ratchet)	(1)
33	16-01-1055	Rotor Assembly (for 1/2" ratchet)	(1)
34	12-20-2556	Service Nameplate	(1)

FIG.	PART NO.	DESCRIPTION OF PART	NO. REQ.
35	42-55-0300	Zippered Tool Case	(1)
36	42-04-0810	1/2" to 3/8" Adapter (Not Shown)	(1)
37	49-16-2558	Rubber Boot (Optional, Accessory)	(1)

FIG. 23,34 NOTES
Prior to installing a new service nameplate, apply isopropyl alcohol to the handle cover with a clean, lint free applicator and allowed to dry.

25 Use a thin blunt punch with the same OD or a similar tool like a finishing nail with the same OD and the pointed tip ground down to remove spring pin from the handle halves and switch paddle. **As an aid, be sure to prop up that corner end of ratchet to support the tapping out of the spring pin.** When reinstalling pin, align the holes and carefully press or tap the pin in place.

FIG. LUBRICATION (Type 'E' Grease, No. 49-08-4122):
5 Apply a moderate coating of grease to the small cylindrical surface that goes into driver bushing and to the large cylindrical surface that is surrounded by the two needle bearings.
6 Apply a moderate coating of grease to the three axles of the carrier assembly prior to installing the planet gears.
8 Apply a light coat of grease to the surface of the washer.
9,33 Apply a heavy coating of grease to the inside diameter gear teeth of the ring gear and the teeth of the motor pinion.



NOTE:

Wires of the electronics assembly (32) are routed in traps and cavities in the right handle half (23).

To replace the Electronics Assembly (32):

Remove four T-10 handle screws (22) from right handle half (23) and two T-10 handle/gear case screws (21) from right handle half.

Gently turn tool over and remove two T-10 handle/gear case screws (21) from left handle half.

Carefully remove the left handle half to expose the electronics assembly.

Use a hex key to remove the three socket head screws (19) and slide stator/rotor/motor mount plate out of yoke housing assembly (31).

Rotor assembly (33) must be removed from the stator by securing the rotor fan and unscrewing the hex nut (20) outside of motor plate (18).

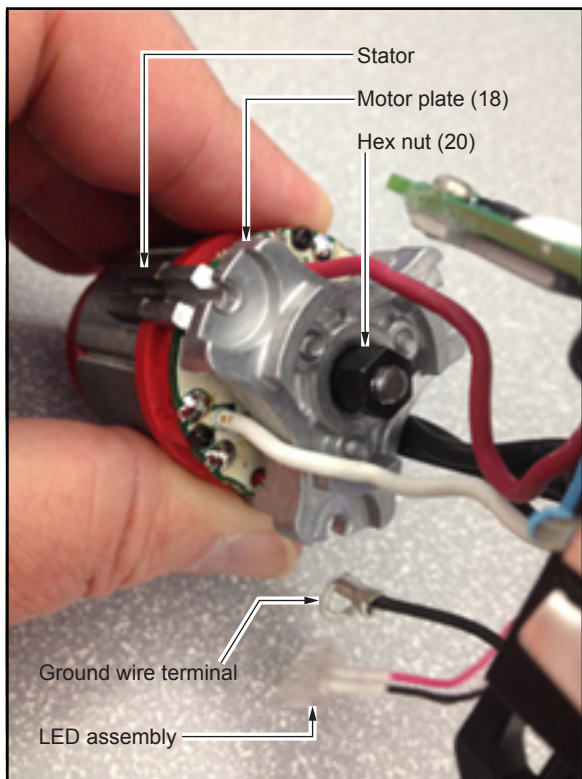
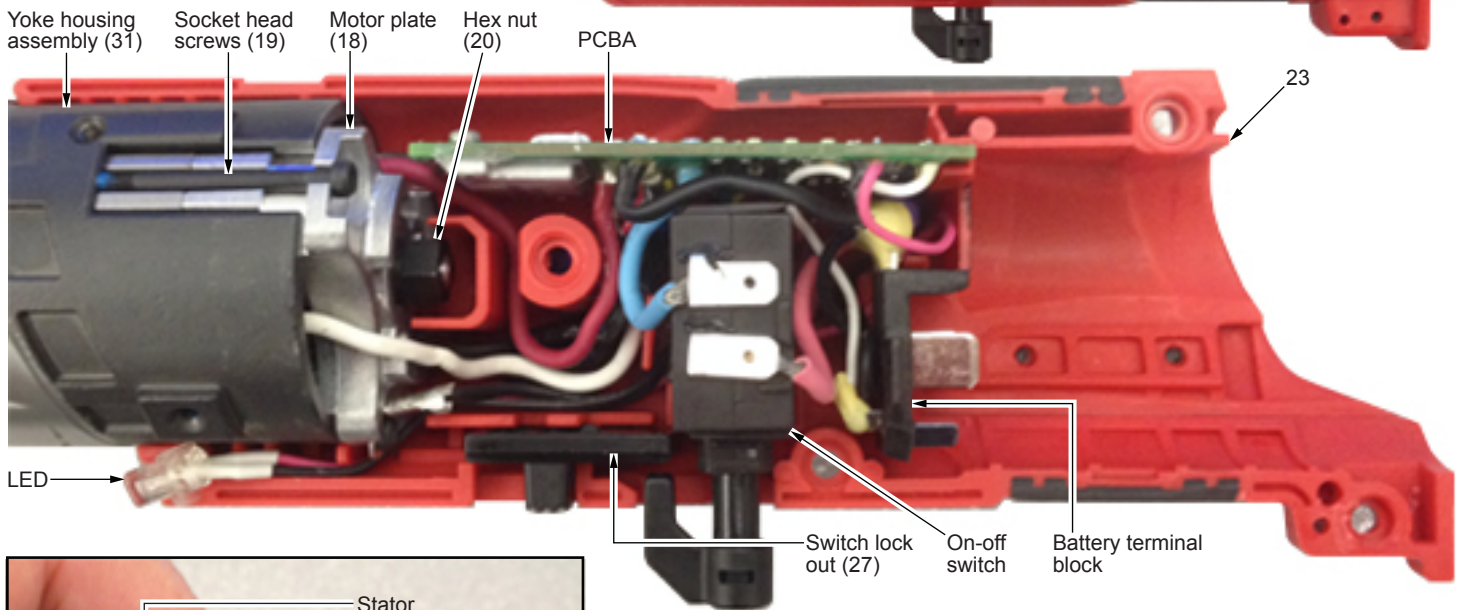

SEE NEXT PAGE FOR SERVICE INSTRUCTIONS TO AID WITH THE REMOVAL AND INSTALLATION OF ELECTRONICS ASSEMBLY (32).

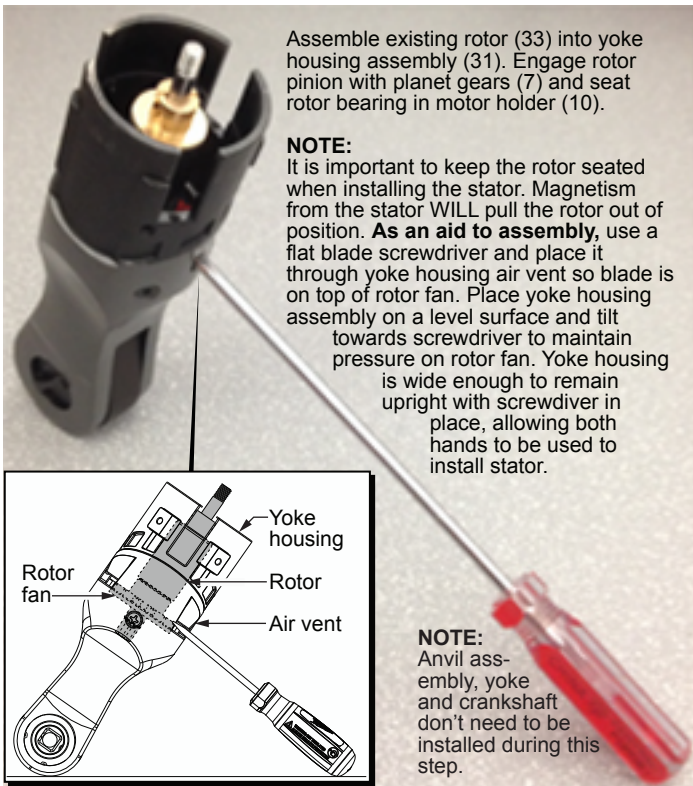

Assemble existing rotor (33) into yoke housing assembly (31). Engage rotor pinion with planet gears (7) and seat rotor bearing in motor holder (10).

NOTE:

It is important to keep the rotor seated when installing the stator. Magnetism from the stator WILL pull the rotor out of position. **As an aid to assembly**, use a flat blade screwdriver and place it through yoke housing air vent so blade is on top of rotor fan. Place yoke housing assembly on a level surface and tilt towards screwdriver to maintain pressure on rotor fan. Yoke housing is wide enough to remain upright with screwdriver in place, allowing both hands to be used to install stator.

NOTE:

Anvil assembly, yoke and crankshaft don't need to be installed during this step.



Orient stator with red wire to the top of tool. Place stator assembly into yoke housing and over rotor.

Slide the existing bushing (14) over threaded rotor spindle. Work existing motor plate/bearing/bearing plate assembly (15,16,17,18) through stator wires and over threaded rotor spindle. Slide the three legs of motor plate into the corresponding channels of yoke housing assembly.

Secure motor plate with three socket head screws (19), being sure to capture the ground terminal, positioned at bottom. Tighten the three screws uniformly using a 2mm hex key.

Secure rotor with hex nut (20) as explained below.

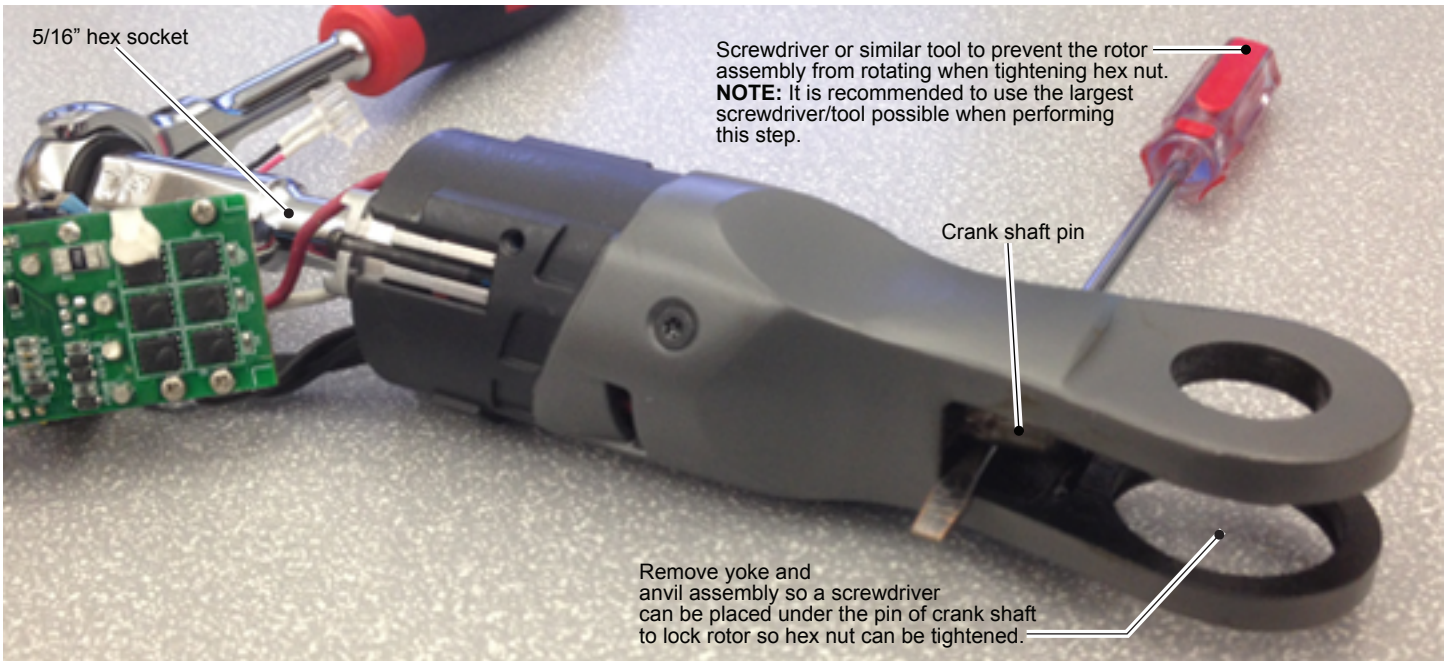

5/16" hex socket

Screwdriver or similar tool to prevent the rotor assembly from rotating when tightening hex nut.

NOTE: It is recommended to use the largest screwdriver/tool possible when performing this step.

Crank shaft pin

Remove yoke and anvil assembly so a screwdriver can be placed under the pin of crank shaft to lock rotor so hex nut can be tightened.

To properly tighten hex nut (20) to rotor (33), it is important to lock rotor and keep it from spinning. The recommended approach is illustrated above.

With a snap ring pliers, remove snap ring (1k). Carefully remove the anvil kit (1) being sure to keep the friction plate (1j) pressed against it. Remove yoke (2) and bushing (4) exposing the 'pin' of crank shaft (5).

With a screwdriver or similar tool, slide under crank shaft pin and wedge between pin and yoke housing, preventing crank shaft and all gearing (including rotor pinion) from moving. Use a 5/16" socket to secure hex nut to rotor spindle. Tighten to 33-37 kg-cm (approx. 28-32 in-lbs).

Remove screwdriver and reinstall bushing and yoke onto crank shaft pin. Carefully place anvil kit and friction plate back into yoke and secure with snap ring.

Place yoke assembly in right handle half. Prior to installing switch and PCBA, place LED assembly in housing half. Route LED wires and ground wire through channels and traps, then behind the switch as shown above. Be sure all wires are pressed down firmly.

Place switch, PCBA and battery terminal block into the handle slots and cavities. Be sure those components are seated firmly and squarely. Pay particular attention that excess wires are tucked behind the battery terminal block and that no wires will interfere with the installation of the other handle half.

Install the switch lock-out slide (27). Carefully place the left handle half (24) onto the right handle half. Be sure the handles fit together properly and secure with screws (21 and 22).

Check for proper functionality of switch and switch lock-out slide. Install battery to make sure tool runs properly.

Install switch paddle (26) and secure with spring pin (25).