

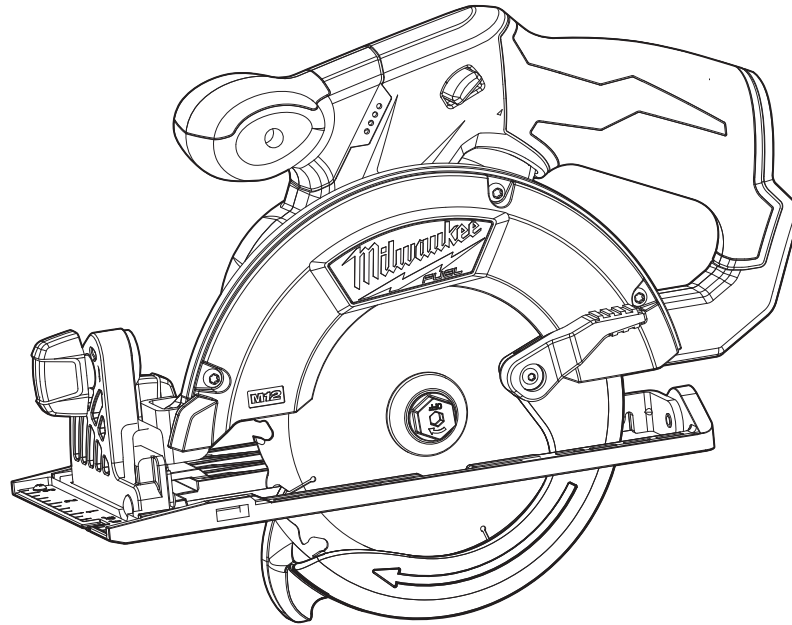

OPERATOR'S MANUAL

Cat. No.

2530-20



5-3/8" (136 mm) CIRCULAR SAW

TO REDUCE THE RISK OF INJURY, USER MUST READ AND UNDERSTAND OPERATOR'S MANUAL.

GENERAL POWER TOOL SAFETY WARNINGS

WARNING Read all safety warnings, instructions, illustrations and specifications provided with this power tool. Failure to follow all instructions listed below may result in electric shock, fire and/or serious injury. Save all warnings and instructions for future reference. The term "power tool" in the warnings refers to your mains-operated (corded) power tool or battery-operated (cordless) power tool.

WORK AREA SAFETY

- Keep work area clean and well lit. Cluttered or dark areas invite accidents.
- Do not operate power tools in explosive atmospheres, such as in the presence of flammable liquids, gases or dust. Power tools create sparks which may ignite the dust or fumes.
- Keep children and bystanders away while operating a power tool. Distractions can cause you to lose control.

ELECTRICAL SAFETY

- Power tool plugs must match the outlet. Never modify the plug in any way. Do not use any adapter plugs with earthed (grounded) power tools. Unmodified plugs and matching outlets will reduce risk of electric shock.
- Avoid body contact with earthed or grounded surfaces, such as pipes, radiators, ranges and refrigerators. There is an increased risk of electric shock if your body is earthed or grounded.
- Do not expose power tools to rain or wet conditions. Water entering a power tool will increase the risk of electric shock.
- Do not abuse the cord. Never use the cord for carrying, pulling or unplugging the power tool. Keep cord away from heat, oil, sharp edges or moving parts. Damaged or entangled cords increase the risk of electric shock.
- When operating a power tool outdoors, use an extension cord suitable for outdoor use. Use of a cord suitable for outdoor use reduces the risk of electric shock.
- If operating a power tool in a damp location is unavoidable, use a ground fault circuit interrupter (GFCI) protected supply. Use of an GFCI reduces the risk of electric shock.

PERSONAL SAFETY

- Stay alert, watch what you are doing and use common sense when operating a power tool. Do not use a power tool while you are tired or under the influence of drugs, alcohol or medication. A moment of inattention while operating power tools may result in serious personal injury.
- Use personal protective equipment. Always wear eye protection. Protective equipment such as a dust mask, non-skid safety shoes, hard hat or hearing protection used for appropriate conditions will reduce personal injuries.
- Prevent unintentional starting. Ensure the switch is in the off-position before connecting to power source and/or battery pack, picking up or carrying the tool. Carrying power tools with your finger on the switch or energizing power tools that have the switch on invites accidents.
- Remove any adjusting key or wrench before turning the power tool on. A wrench or a key left attached to a rotating part of the power tool may result in personal injury.
- Do not overreach. Keep proper footing and bal-

ance at all times. This enables better control of the power tool in unexpected situations.

- Dress properly. Do not wear loose clothing or jewelry. Keep your hair and clothing away from moving parts. Loose clothes, jewelry or long hair can be caught in moving parts.
- If devices are provided for the connection of dust extraction and collection facilities, ensure these are connected and properly used. Use of dust collection can reduce dust-related hazards.
- Do not let familiarity gained from frequent use of tools allow you to become complacent and ignore tool safety principles. A careless action can cause severe injury within a fraction of a second.

POWER TOOL USE AND CARE

- Do not force the power tool. Use the correct power tool for your application. The correct power tool will do the job better and safer at the rate for which it was designed.
- Do not use the power tool if the switch does not turn it on and off. Any power tool that cannot be controlled with the switch is dangerous and must be repaired.
- Disconnect the plug from the power source and/or remove the battery pack, if detachable, from the power tool before making any adjustments, changing accessories, or storing power tools. Such preventive safety measures reduce the risk of starting the power tool accidentally.
- Store idle power tools out of the reach of children and do not allow persons unfamiliar with the power tool or these instructions to operate the power tool. Power tools are dangerous in the hands of untrained users.
- Maintain power tools and accessories. Check for misalignment or binding of moving parts, breakage of parts and any other condition that may affect the power tool's operation. If damaged, have the power tool repaired before use. Many accidents are caused by poorly maintained power tools.
- Keep cutting tools sharp and clean. Properly maintained cutting tools with sharp cutting edges are less likely to bind and are easier to control.
- Use the power tool, accessories and tool bits etc. in accordance with these instructions, taking into account the working conditions and the work to be performed. Use of the power tool for operations different from those intended could result in a hazardous situation.
- Keep handles and grasping surfaces dry, clean and free from oil and grease. Slippery handles and grasping surfaces do not allow for safe handling and control of the tool in unexpected situations.

BATTERY TOOL USE AND CARE

- Recharge only with the charger specified by the manufacturer. A charger that is suitable for one type of battery pack may create a risk of fire when used with another battery pack.
- Use power tools only with specifically designated battery packs. Use of any other battery packs may create a risk of injury and fire.

- When battery pack is not in use, keep it away from other metal objects, like paper clips, coins, keys, nails, screws or other small metal objects, that can make a connection from one terminal to another. Shorting the battery terminals together may cause burns or a fire.
- Under abusive conditions, liquid may be ejected from the battery; avoid contact. If contact accidentally occurs, flush with water. If liquid contacts eyes, additionally seek medical help. Liquid ejected from the battery may cause irritation or burns.
- Do not use a battery pack or tool that is damaged or modified. Damaged or modified batteries may exhibit unpredictable behavior resulting in fire, explosion or risk of injury.
- Do not expose a battery pack or tool to fire or excessive temperature. Exposure to fire or temperature above 265°F (130°C) may cause explosion.
- Follow all charging instructions and do not charge the battery pack or tool outside the temperature range specified in the instructions. Charging improperly or at temperatures outside the specified range may damage the battery and increase the risk of fire.

SERVICE

- Have your power tool serviced by a qualified repair person using only identical replacement parts. This will ensure that the safety of the power tool is maintained.
- Never service damaged battery packs. Service of battery packs should only be performed by the manufacturer or authorized service providers.

SAFETY INSTRUCTIONS FOR ALL SAWS

Cutting procedures

- DANGER:** Keep hands away from cutting area and the blade. Keep your second hand on auxiliary handle, or motor housing. If both hands are holding the saw, they cannot be cut by the blade.
- Do not reach underneath the workpiece. The guard cannot protect you from the blade below the workpiece.
- Adjust the cutting depth to the thickness of the workpiece. Less than a full tooth of the blade teeth should be visible below the workpiece.
- Never hold piece being cut in your hands or across your leg. Secure the workpiece to a stable platform. It is important to support the work properly to minimize body exposure, blade binding, or loss of control.
- Hold the power tool by insulated gripping surfaces, when performing an operation where the cutting tool may contact hidden wiring. Contact with a "live" wire will also make exposed metal parts of the power tool "live" and could give the operator an electric shock.
- When ripping, always use a rip fence or straight edge guide. This improves the accuracy of cut and reduces the chance of blade binding.
- Always use blades with correct size and shape (diamond versus round) of arbour holes. Blades that do not match the mounting hardware of the saw will run off-center, causing loss of control.
- Never use damaged or incorrect blade washers or bolt. The blade washers and bolt were specially designed for your saw, for optimum performance and safety of operation.

Kickback causes and related warnings

- Kickback is a sudden reaction to a pinched, jammed or misaligned saw blade, causing an uncontrolled saw to lift up and out of the workpiece toward the operator;
 - When the blade is pinched or jammed tightly by the kerf closing down, the blade stalls and the motor reaction drives the unit rapidly back toward the operator;
 - If the blade becomes twisted or misaligned in the cut, the teeth at the back edge of the blade can dig into the top surface of the wood causing the blade to climb out of the kerf and jump back toward the operator. Kickback is the result of saw misuse and/or incorrect operating procedures or conditions and can be avoided by taking proper precautions as given below:
 - Maintain a firm grip with both hands on the saw and position your arms to resist kickback forces. Position your body to either side of the blade, but not in line with the blade. Kickback could cause the saw to jump backwards, but kickback forces can be controlled by the operator, if proper precautions are taken.
 - When blade is binding, or when interrupting a cut for any reason, release the trigger and hold the saw motionless in the material until the blade comes to a complete stop. Never attempt to remove the saw from the work or pull the saw backward while the blade is in motion or kickback may occur. Investigate and take corrective actions to eliminate the cause of blade binding.
 - When restarting a saw in the workpiece, centre the saw blade in the kerf and check that saw teeth are not engaged into the material. If saw blade is binding, it may walk up or kickback from the workpiece as the saw is restarted.
 - Support large panels to minimise the risk of blade pinching and kickback. Large panels tend to sag under their own weight. Supports must be placed under the panel on both sides, near the line of cut and near the edge of the panel.
 - Do not use dull or damaged blades. Unsharpened or improperly set blades produce narrow kerf causing excessive friction, blade binding and kickback.
 - Blade depth and bevel adjusting locking levers must be tight and secure before making the cut. If blade adjustment shifts while cutting, it may cause binding and kickback.
 - Use extra caution when sawing into existing walls or other blind areas. The protruding blade may cut objects that can cause kickback.
- #### Lower guard function
- Check lower guard for proper closing before each use. Do not operate the saw if lower guard does not move freely and close instantly. Never clamp or tie the lower guard into the open position. If saw is accidentally dropped, lower guard may be bent. Raise the lower guard with the retracting handle and make sure it moves freely and does not touch the blade or any other part, in all angles and depths of cut.
 - Check the operation of the lower guard spring. If the guard and the spring are not operating properly, they must be serviced before use. Lower guard may operate sluggishly due to damaged parts, gummy deposits, or a build-up of debris.
 - The lower guard should be retracted manually only for special cuts such as "plunge cuts" and "compound cuts." Raise lower guard by retracting handle and as soon as blade enters the material, the lower guard must be released. For all other sawing, the lower guard should operate automatically.

- **Always observe that the lower guard is covering the blade before placing saw down on bench or floor.** An unprotected, coasting blade will cause the saw to walk backwards, cutting whatever is in its path. Be aware of the time it takes for the blade to stop after switch is released.
- **Maintain labels and nameplates.** These carry important information. If unreadable or missing, contact a **MILWAUKEE** service facility for a free replacement.
- **WARNING** Some dust created by power sanding, sawing, grinding, drilling, and other construction activities contains chemicals known to cause can-

cer, birth defects or other reproductive harm. Some examples of these chemicals are:

- lead from lead-based paint
- crystalline silica from bricks and cement and other masonry products, and
- arsenic and chromium from chemically-treated lumber.

Your risk from these exposures varies, depending on how often you do this type of work. To reduce your exposure to these chemicals: work in a well ventilated area, and work with approved safety equipment, such as those dust masks that are specially designed to filter out microscopic particles.

SPECIFICATIONS

| Cat. No. | Volts DC | No Load RPM | Blade Size | Arbor | Depth of Cut at 90° | Depth of Cut at 45° |
|----------|----------|-------------|-------------------------------------|-------|---------------------|---------------------|
| 2530-20 | 12 | 3600 | 5-3/8" or 5-1/2" (136 or 140 mm) | 10 mm | 0 to 1-5/8" | 0 to 1-1/8" |

FUNCTIONAL DESCRIPTION

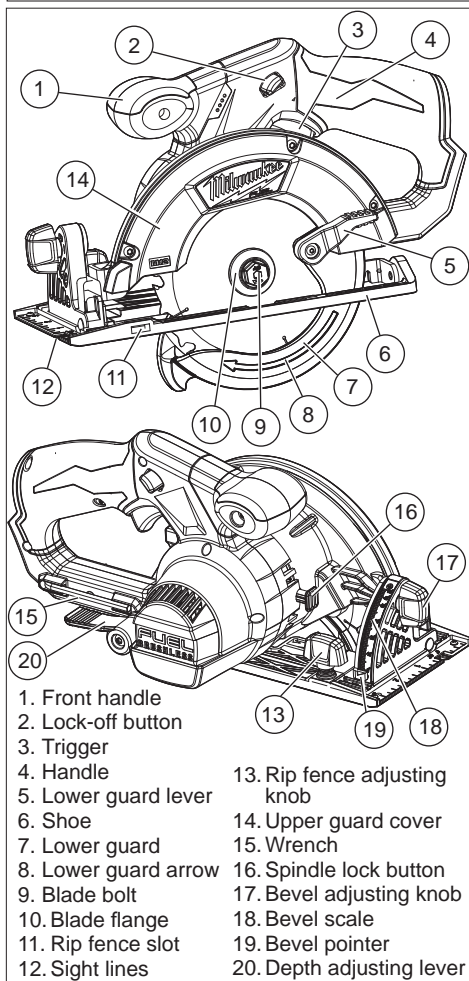

1. Front handle
2. Lock-off button
3. Trigger
4. Handle
5. Lower guard lever
6. Shoe
7. Lower guard
8. Lower guard arrow
9. Blade bolt
10. Blade flange
11. Rip fence slot
12. Sight lines
13. Rip fence adjusting knob
14. Upper guard cover
15. Wrench
16. Spindle lock button
17. Bevel adjusting knob
18. Bevel scale
19. Bevel pointer
20. Depth adjusting lever

SYMBOLOLOGY

| | |
|---------------------------------------|--|
| V | Volts |
| --- | Direct Current |
| n ₀ XXXXmin. ⁻¹ | No Load Revolutions per Minute (RPM) |
| cULUS | Underwriters Laboratories, Inc. United States and Canada |

ASSEMBLY

WARNING Recharge only with the charger specified for the battery. For specific charging instructions, read the operator's manual supplied with your charger and battery.

Inserting/Removing the Battery

To **remove** the battery, push in the release buttons and pull the battery pack away from the tool. To **insert** the battery, slide the pack into the body of the tool. Make sure it latches securely into place.

WARNING Always remove battery pack before changing or removing accessories. Only use accessories specifically recommended for this tool. Others may be hazardous.

Selecting Blade

Always:

- Use the correct blade type for your application (Fig. 1). Using the wrong blade may result in reduced performance or damage to the blade.
- Use sharp, thin kerf blades with a maximum safe operating speed greater than the no load RPM marked on the tool's nameplate. Dull blades tend to overload the tool and increase the chance of KICKBACK.
- Use the appropriate size blade and arbor found in the specifications chart.

Never:

- Use blades that are cracked or have broken teeth.
- Use any type of abrasive cut-off wheel or dry diamond cutting blades.

- Sharpen ferrous metal cutting blades. Read the blade manufacturer's instructions before use. Refer to the blade manufacturer's recommendations regarding sharpening of the blade.

Fig. 1

- Rip & Crosscut**
A multi-purpose blade for ripping, cross cutting and mitering in hardwoods, softwoods, plywood and composition materials.
- Framing-Rip**
Designed for fast and accurate ripping along the grain in hard- or softwoods where a smooth cross cut is not necessary.
- Plywood-Veneer**
Recommended for cutting plywood, composition materials and all types of wood where a slightly smoother finish is needed.
- Finish & Trim**
Especially designed for cross cutting and mitering in materials where a very smooth cut is necessary.

Checking the Operation of the Lower Guard

Check the operation and condition of the lower guard lever. If the guard and the lever are not operating properly, they must be serviced before use. Lower guard may operate sluggishly due to damaged parts, gummy deposits, or a buildup of debris.

1. Unplug tool before checking the lower guard.
2. Place the tool on its side.
3. Grasp the lower guard by the sides and push it all the way back into the blade housing.
4. Release the lower guard.
 - If the guard immediately springs back into place, it is working correctly and you may continue with use.
 - If the guard does not immediately spring back into place, clean the upper and lower guards to remove all chips and debris. Then, check the operation again by starting with step 1.
 - If the guard still does not immediately spring back into place, contact a **MILWAUKEE** service facility for repairs.

Installing and Removing Blades

1. **Remove battery pack before installing or removing blades.**
 2. Place the saw on a flat surface with the blade facing upwards. To remove the bolt from the spindle, push in the spindle lock button. While holding in the spindle lock button, use the wrench provided with the tool to turn the bolt clockwise. Remove the bolt and blade flange.
 3. Slide the lower guard lever up to raise the lower guard. Remove the blade from the spindle. Always clean the spindle, upper guard and lower guard to remove any dirt and sawdust.
- NOTE:** Do not remove inner blade flange. Larger diameter of inner flange should face the blade.

Fig. 2



4. To install a blade, place the blade on the spindle with the teeth pointing in the same direction as the arrow on the lower guard. Release the lower guard lever.
5. Place the blade flange on the spindle and hand tighten the bolt.
6. While holding in the spindle lock button, use the wrench to turn the bolt counterclockwise and tighten.

Adjusting Depth

1. Remove battery pack.
2. To adjust the depth of the cut, hold the saw by the handle and loosen the depth adjusting lever by pushing it up towards the motor housing.
3. Raise or lower the shoe to the desired position. Markings in 1/4" increments are located on the inner side of the upper guard for depth setting. For the proper depth setting, the blade should extend no more than 1/8" to 1/4" below the material being cut (Fig. 4).

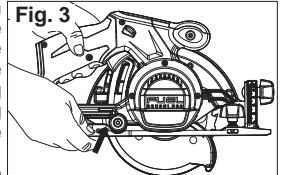
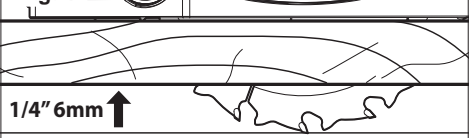

Fig. 4



4. Press down on the depth adjusting lever to secure the shoe position.

Adjusting Bevel Angle

1. Remove battery pack.
2. To adjust the angle of the cut, hold the saw by the handle and loosen the bevel adjusting knob (Fig. 5).

Fig. 5

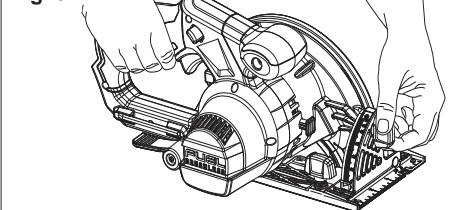

3. Hold the front of the shoe and rotate the saw by the handle to the desired angle as indicated by the markings on the bevel scale.
4. Tighten the bevel adjusting knob securely.

Adjusting the Blade to Shoe

The shoe has been adjusted at the factory to a 90° setting. Inspect the saw regularly to make sure the blade is 90° to the shoe.

1. Remove battery pack.
2. Set the bevel pointer to zero.
3. To make sure the blade is 90° to the shoe, place saw on the blade side and retract lower guard. Place a square against the blade and shoe to inspect the degree setting (Fig. 6).

Fig. 6

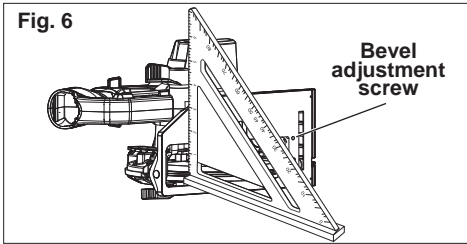

Bevel adjustment screw

4. To adjust the degree setting, loosen the bevel adjusting knob. Turn the bevel adjustment screw in or out until the blade is at a 90° angle with the shoe.
5. Tighten the bevel adjusting knob securely.

OPERATION

WARNING Always remove battery pack before changing or removing accessories. Only use accessories specifically recommended for this tool. Others may be hazardous.

WARNING To reduce the risk of injury, keep hands away from the blade and other moving parts. Always wear safety goggles or glasses with side shields. Use only specifically recommended accessories. Others may be hazardous.

Kickback causes and related warnings

- Kickback is a sudden reaction to a pinched, bound or misaligned saw blade, causing an uncontrolled saw to lift up and out of the workpiece toward the operator;
- When the blade is pinched or bound tightly by the kerf closing down, the blade stalls and the motor reaction drives the unit rapidly back toward the operator;
- If the blade becomes twisted or misaligned in the cut, the teeth at the back edge of the blade can dig into the top surface of the wood causing the blade to climb out of the kerf and jump back toward the operator.

Kickback is the result of saw misuse and/or incorrect operating procedures or conditions and can be avoided by taking proper precautions as given below:

- **Maintain a firm grip with both hands on the saw and position your arms to resist kickback forces. Position your body to either side of the blade, but not in line with the blade.** Kickback could cause the saw to jump backwards, but kickback forces can be controlled by the operator, if proper precautions are taken.
- **When blade is binding, or when interrupting a cut for any reason, release the trigger and hold the saw motionless in the material until the blade comes to a complete stop. Never attempt to remove the saw from the work or pull the saw backward while the blade is in motion or kickback may occur.** Investigate and take corrective actions to eliminate the cause of blade binding.
- **When restarting a saw in the workpiece, centre the saw blade in the kerf and check that saw teeth are not engaged into the material.** If saw

blade is binding, it may walk up or kickback from the workpiece as the saw is restarted.

- **Support large panels to minimise the risk of blade pinching and kickback.** Large panels tend to sag under their own weight. Supports must be placed under the panel on both sides, near the line of cut and near the edge of the panel.
- **Do not use dull or damaged blades.** Unsharpened or improperly set blades produce narrow kerf causing excessive friction, blade binding and kickback.
- **Blade depth and bevel adjusting locking levers must be tight and secure before making cut.** If blade adjustment shifts while cutting, it may cause binding and kickback.
- **Use extra caution when sawing into existing walls or other blind areas.** The protruding blade may cut objects that can cause kickback.

General Operation

Always clamp the workpiece securely on a saw horse or bench. See "APPLICATIONS" for the correct way to support your work in different situations.

1. Draw a cutting line. Place the front of the shoe on the edge of the workpiece without making blade contact. Hold the handle with one hand and the front handle with the other (Fig. 7).

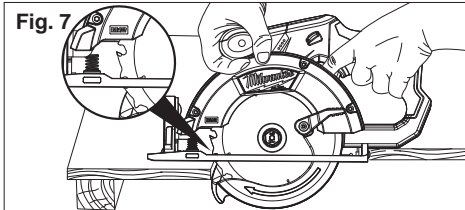

Fig. 7

2. Line up the sight line with your cutting line. Position your arms and body to resist KICKBACK.
3. To start the saw, push the lock-off button down while pulling the trigger. Allow the motor to reach full speed before beginning cut.
4. While cutting, keep the shoe flat against the workpiece and maintain a firm grip. Do not force the saw through the workpiece. Forcing a saw can cause KICKBACK.
5. If making a partial cut, restarting in mid-cut or correcting direction, allow the blade to come to a complete stop. To resume cutting, center the blade in the kerf, back the saw away from cutting edge a few inches, push the lock-off button down while pulling the trigger and re-enter the cut slowly.
6. If the saw binds and stalls, maintain a firm grip and release the trigger immediately. Hold the saw motionless in the workpiece until the blade comes to a complete stop.
7. After finishing a cut, be sure the lower guard closes and the blade comes to a complete stop before setting the saw down.
8. When cutting plastic, avoid overheating the blade and blade teeth to prevent melting the workpiece.

Electric Brake

The electric brake engages when the trigger is released, causing the blade to stop and allowing you to proceed with your work. Generally, the saw blade stops within two seconds. However, there may be a delay between the time you release the trigger and when the brake engages. Occasionally the brake may miss completely. If the brake misses frequently, the saw

needs servicing by an authorized MILWAUKEE service facility. The brake is not a substitute for the guard, and you must always wait for the blade to stop completely before removing the saw from the workpiece.

Troubleshooting

If the blade does not follow a straight line:

- Teeth are dull. This is caused by hitting a hard object such as a nail or stone, dulling teeth on one side. The blade tends to cut to the side with the sharpest teeth.
- Shoe is out of line or bent
- Blade is bent
- Rip fence or guide is not being used
- If the blade binds, smokes or turns blue from friction:
 - Blade is dull
 - Blade is on backwards
 - Blade is bent
 - Blade is dirty
- Workpiece is not properly supported
- Incorrect blade is being used
- Battery charge is low

APPLICATIONS

Cutting Large Panels

Large panels and long boards sag or bend if they are not correctly supported. If you attempt to cut without leveling and properly supporting the workpiece, the blade will tend to bind, causing KICKBACK. Support large panels. Be sure to set the depth of the cut so that you only cut through the workpiece, not through the supports.

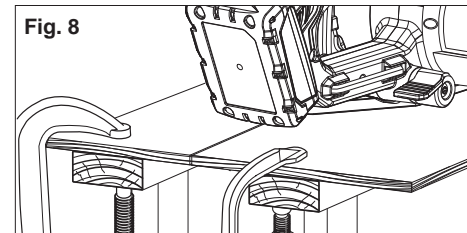

Fig. 8

Cross-Cutting Wood

Cross-cutting is cutting across the grain. Select the proper blade for your job. Advance the saw slowly to avoid splintering the wood.

Ripping Wood

Ripping is cutting lengthwise with the grain. Select the proper blade for your job. Use a rip fence for rips 4" wide or less. To install the rip fence, slide the bar through the rip fence slot in either side of the shoe. The width of the cut is the distance from the inside of the blade to the inside edge of the rip fence. Adjust the rip fence for the desired width, and lock the setting by tightening the rip fence adjusting knob. When ripping widths greater than 4", clamp or tack 1" lumber to workpiece and use the inside edge of the shoe as a guide.

WARNING To reduce the risk of electric shock, check work area for hidden pipes and wires before making plunge cuts.

Plunge Cutting

Plunge cuts are made in the middle of the workpiece when it can not be cut from an edge. We recommend

using a Sawzall® reciprocating saw or jig saw for this type of cut. However, if you must use a circular saw to make a plunge cut, USE EXTREME CAUTION. To maintain control of the saw during plunge cutting, keep both hands on the saw.

1. Beginning at a corner, line up the sight line with your cutting line. Tilt the saw forward, firmly fixing the front of the shoe on the workpiece (Fig. 9). The blade should be just above cutting line, but not touching it. Raise the lower guard using the lower guard lever.

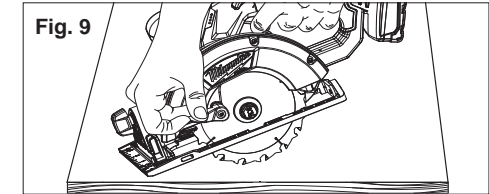

Fig. 9

2. To start the saw, push the lock-off button down while pulling the trigger. Allow the motor to reach full speed before beginning cut. Using the front of the shoe as a hinge point, gradually lower the back end of the saw into the workpiece. Release the lower guard lever and grasp the front handle.
3. When the shoe rests flat against workpiece, advance the saw to the far corner (Fig. 10). Release the trigger and allow the blade to come to a complete stop before removing it from workpiece. Repeat the above steps for each side of the opening. Use a Sawzall® reciprocating saw, jig saw or small hand saw to finish the corners if they are not completely cut through.

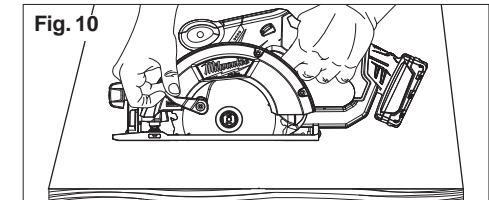

Fig. 10

Overloading

Continuous overloading may cause permanent damage to tool or battery pack.

MAINTENANCE

WARNING To reduce the risk of injury, always unplug the charger and remove the battery pack from the charger or tool before performing any maintenance. Never disassemble the tool, battery pack or charger. Contact a MILWAUKEE service facility for ALL repairs.