



SERVICE PARTS LIST

BULLETIN NO.
54-47-2520

SPECIFY CATALOG NO. AND SERIAL NO. WHEN ORDERING PARTS			REVISED BULLETIN
M12™ FUEL™ 3" COMPACT CUT OFF TOOL			
CATALOG NO.	2522-20	STARTING SERIAL NO.	J80A

EXAMPLE:

00	0
----	---

 Component Parts (Small #)
 Are Included When Ordering
 The Assembly (Large #).

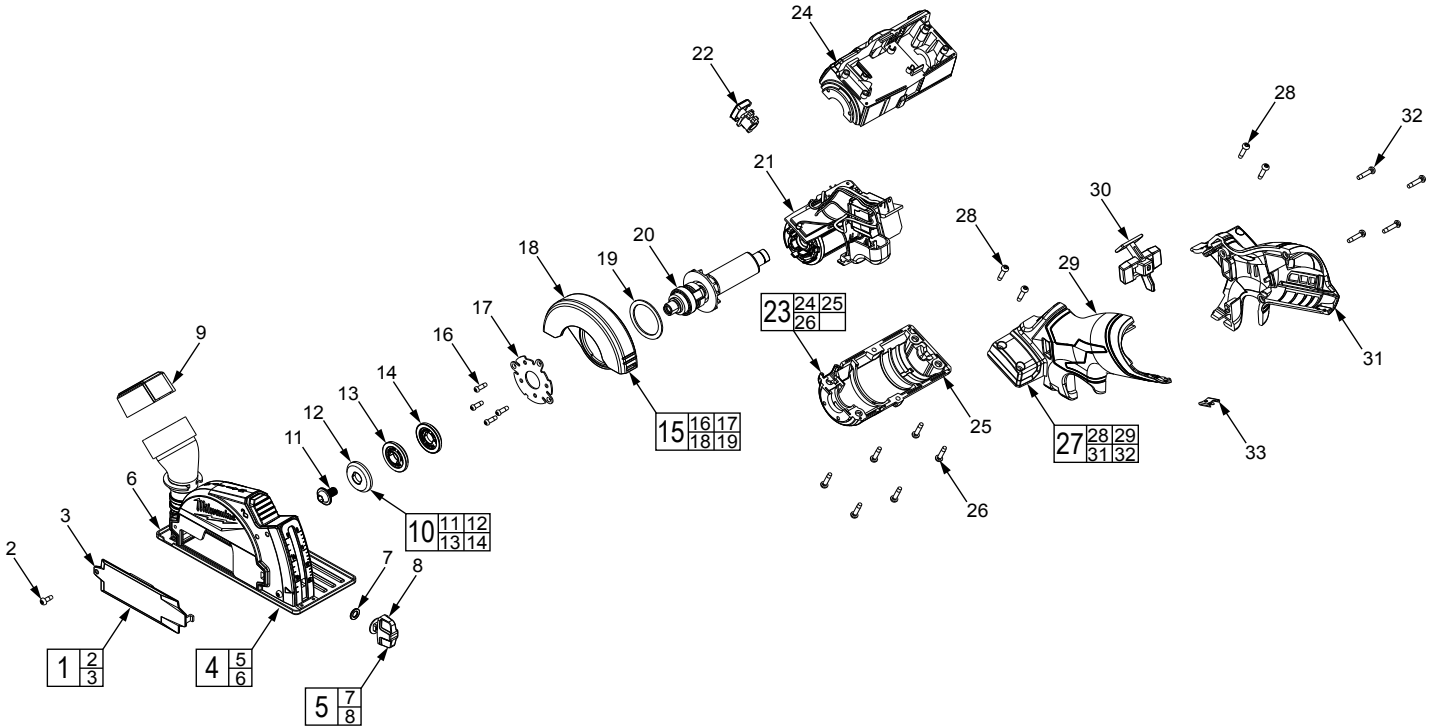

FIG.	PART NO.	DESCRIPTION OF PART	NO. REQ.
1	14-38-2030	Outer Guard Window Kit	(1)
2	-----	Outer Guard Screw	(1)
3	-----	Outer Guard Window	(1)
4	31-15-0830	Shoe Assembly	(1)
5	06-59-0015	Shoe Fastener Kit	(1)
6	-----	Shoe	(1)
7	-----	Washer	(1)
8	-----	Depth Adjustment Knob	(1)
9	31-12-0440	Dust Output Cap	(1)
10	14-46-2075	Flange/Blade Bolt Kit	(1)
11	-----	Round Head Blade Bolt	(1)
12	-----	Top Flange	(1)
13	-----	Bottom Flange	(1)
14	-----	7/16" Bottom Flange	(1)
15	14-32-0255	Guard Kit	(1)
16	-----	M3 x 1.058 PH T8 Torx Screw	(4)
17	-----	Guard Retain Clip	(1)
18	-----	Inner Guard	(1)
19	-----	Washer	(1)
20	16-01-0055	Rotor Assembly	(1)
21	14-20-2020	Electronics Assembly	(1)
22	14-46-2080	Spindle Lock Assembly	(1)
23	14-38-2020	Motor Housing Kit	(1)
24	-----	Top Motor Housing	(1)

FIG.	PART NO.	DESCRIPTION OF PART	NO. REQ.
25	-----	Bottom Motor Housing	(1)
26	-----	M3 x 14 Screw	(6)
27	14-38-2025	Handle Housing Kit	(1)
28	-----	Handle Housing Top Screw	(4)
29	-----	Left Handle	(1)
30	42-42-2020	Forward/Reverse Shuttle	(1)
31	-----	Right Handle w/ Dust Cover	(1)
32	-----	Handle Housing Side Screw	(4)
33	42-70-0058	Housing Clip	(1)
34	49-96-0600	Hex Key (Not Shown)	(1)
35	12-20-2515	Service Nameplate (Not Shown)	(1)
36	10-20-2157	Warning Label (Not Shown)	(1)
37	10-20-2158	Warning Label (Not Shown)	(1)
38	10-20-2159	Warning Label (Not Shown)	(1)

FIG. NOTES
 35, 36 A clean, dry surface is essential for proper performance for any adhesive system. The area intended for application of any adhesive label or nameplate must be prepared by cleaning with isopropyl alcohol. The solvent is to be applied with a clean, lint free applicator and the surface allowed to dry before applying the label or nameplate.
 37, 38