

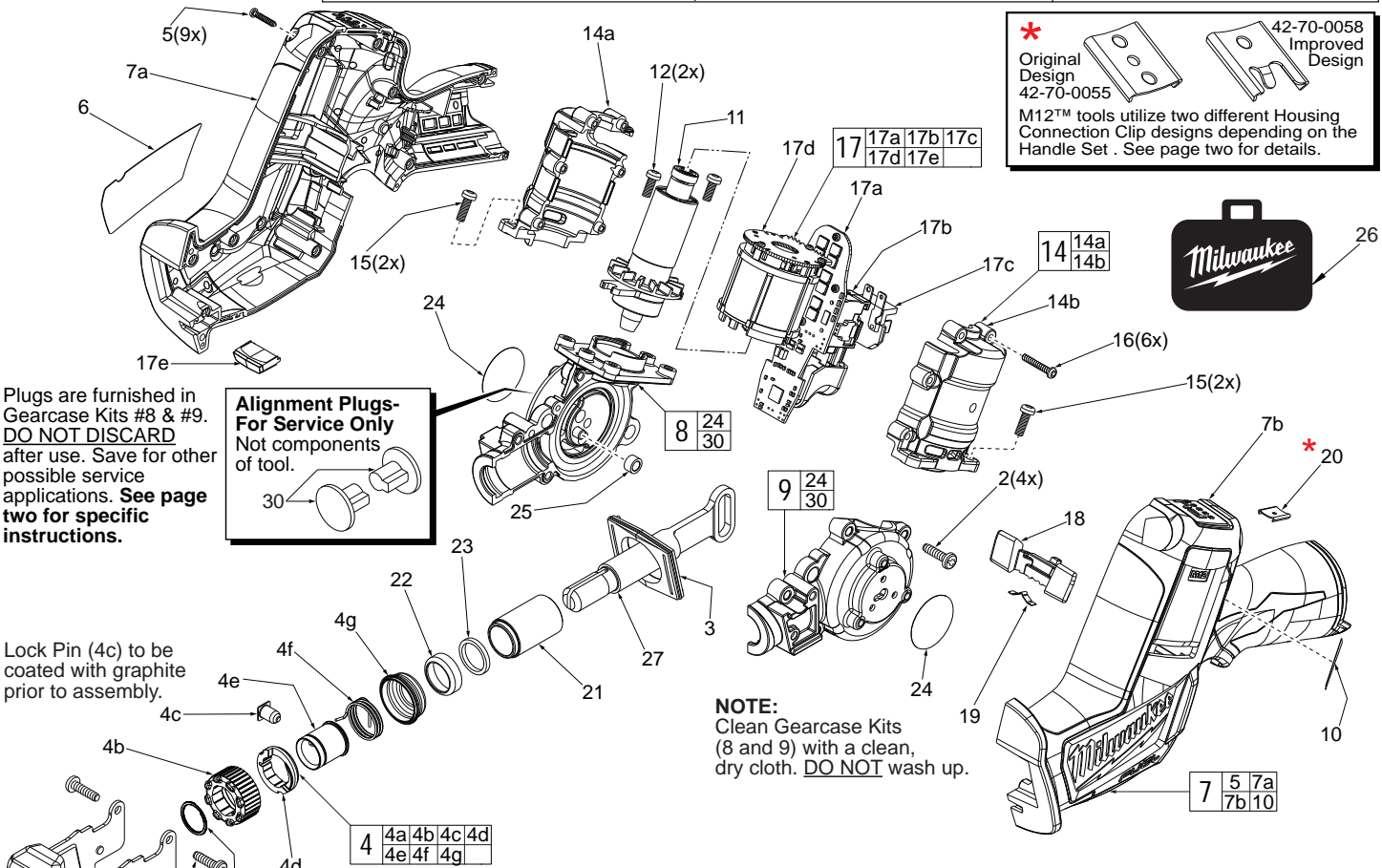

SERVICE PARTS LIST

BULLETIN NO.
54-40-2510

SPECIFY CATALOG NO. AND SERIAL NO. WHEN ORDERING PARTS		REVISED BULLETIN	DATE
M12 FUEL™ Hackzall®			Apr. 2014
CATALOG NO.	2520-20	STARTING SERIAL NO.	F51A
		WIRING INSTRUCTION SEE PAGE 4	



Plugs are furnished in Gearcase Kits #8 & #9. **DO NOT DISCARD** after use. Save for other possible service applications. See page two for specific instructions.

Alignment Plugs - For Service Only
Not components of tool.

Lock Pin (4c) to be coated with graphite prior to assembly.

NOTE:
Clean Gearcase Kits (8 and 9) with a clean, dry cloth. **DO NOT** wash up.

EXAMPLE:
00 0 Component Parts (Small #) Are Included When Ordering The Assembly (Large #).

FIG.	PART NO.	DESCRIPTION OF PART	NO. REQ.
1	45-16-0930	Shoe	(1)
2	06-82-5320	8-32 x 0.63" Pan Hd. Taptite T-20	(6)
3	45-06-1060	Rubber Seal	(1)
4	14-46-1011	Steel Quik-Lok® Blade Clamp Kit	(1)
4a	34-60-3680	Retaining Ring	(1)
4b	42-50-0076	Front Cam	(1)
4c	44-60-0626	Lock Pin	(1)
4d	42-50-0077	Rear Cam	(1)
4e	45-22-0081	Sleeve	(1)
4f	40-50-0161	Torsion Spring	(1)
4g	31-15-0511	Spring Cover	(1)
5	06-82-2385	M2.6 x 14mm ST Pan Hd. T-8 Screw	(9)
6	12-20-2520	Service Nameplate	(1)
7	31-44-2425	Handle Assembly	(1)
7a	-----	Handle Halve - Right	(1)
7b	-----	Handle Halve - Left	(1)
8	14-30-1010	Right Gearcase Assembly	(1)
9	14-30-0990	Left Gearcase Assembly	(1)
10	10-20-4245	Fuel Gauge Label	(1)
11	16-07-2500	Rotor Assembly	(1)
12	05-78-0105	M4 x 10mm Pan Hd. Tapt. T-20 Screw	(2)
14	23-16-1050	Motor Insulator Assembly	(1)
14a	-----	Motor Insulator Halve - Right	(1)
14b	-----	Motor Insulator Halve - Left	(1)
15	05-74-0985	M4 x 12mm Pan Hd. Tapt. T-20 Screw	(4)
16	06-82-1050	4-20 x 0.76" ST Pan Hd. T-10 Screw	(6)
17	23-66-1725	Switch / Electronics Kit	(1)
17a	-----	PCB Assembly	(1)
17b	-----	On-Off Switch	(1)

FIG.	PART NO.	DESCRIPTION OF PART	NO. REQ.
17c	-----	Terminal Block	(1)
17d	-----	Stator Assembly	(1)
17e	-----	LED Assembly	(1)
18	45-24-2450	Locking Shuttle	(1)
19	40-50-1135	Shuttle Spring	(1)
20	42-70-0055	Housing Clip	(1)
21	42-40-1120	Bushing	(1)
22	44-86-0740	Front Cap	(1)
23	45-06-0880	Felt Seal	(1)
24	23-70-3350	Aluminum Tape	(2)
25	44-86-0575	Drive Pin Sleeve	(1)
26	42-55-2520	Contractor Bag	(1)
27	38-50-1570	Spindle	(1)
30	31-53-0280	Alignment Plug - Service Tool (Not component of tool - one per in kits 8 and 9)	(1)

FIG.	LUBRICATION
22,23	Saturate Felt (23) with lightweight oil prior to assembly with Cap (22) onto Bushing (21a) and Spindle (21b).
21a,21b	Lightly coat the O.D. of Spindle Shaft (21b) and I.D. of Bushing (21a) with grease.
21b	Place a dab of grease in the rear slot of Spindle Shaft (21b).
8,9	Place .3 ounce (8.5g) grease in gear cavity of Gearcase Assemblies (8,9).
	Coat the spindle shaft pocket in Gearcase Assemblies (8,9).
8,25	Lightly coat the Drive Pin (component pressed into gear in the right gearcase assembly) and I.D. and O.D. of Drive Pin Sleeve (25) with grease.
8,9,11	Completely coat all of the teeth of the Spiral Bevel Pinion on Rotor Assembly (11) and Spiral Bevel Gears in gearcase assemblies (8 and 9) with grease.

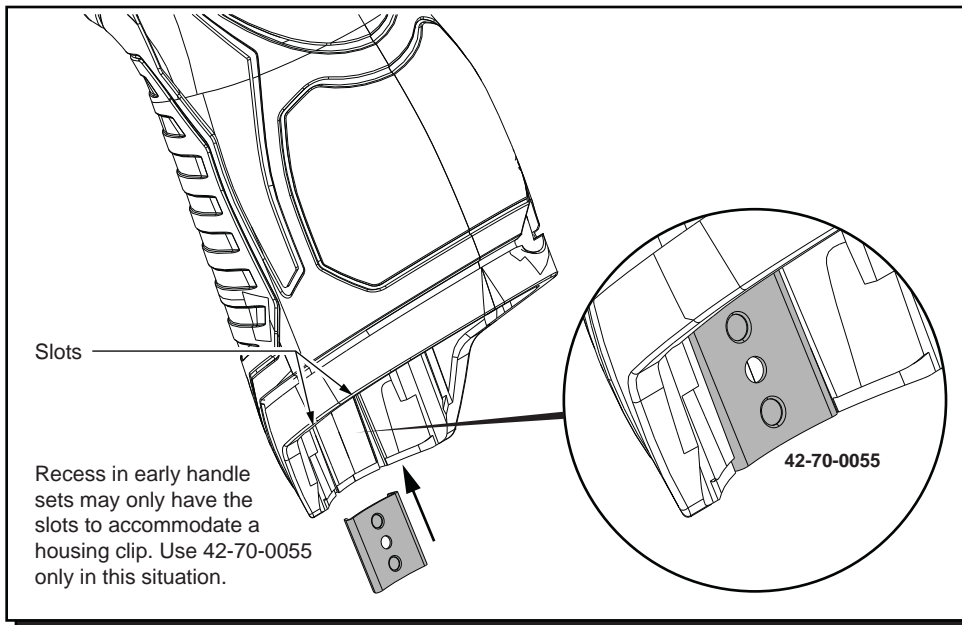

Early M12™ Handle Sets utilize **Housing Connection Clip No. 42-70-0055**. Install this clip design by aligning the side rails of the clip with the two slots in the handle set. Gently push into place with the aid of a small flat blade screwdriver or a similar instrument. Be sure that the clip is properly seated in both slots and that the clip is flush to sub-flush to the end of the handle set. To remove the clip, use the same small flat blade screwdriver or a similar instrument and push the clip out of the handle set. If the clip is loose or will not stay in place, a needle nose pliers can be used to gently bend/pinch the side rails of the clip. If the clip is damaged do not use, replace with a new 42-70-0055 housing clip.

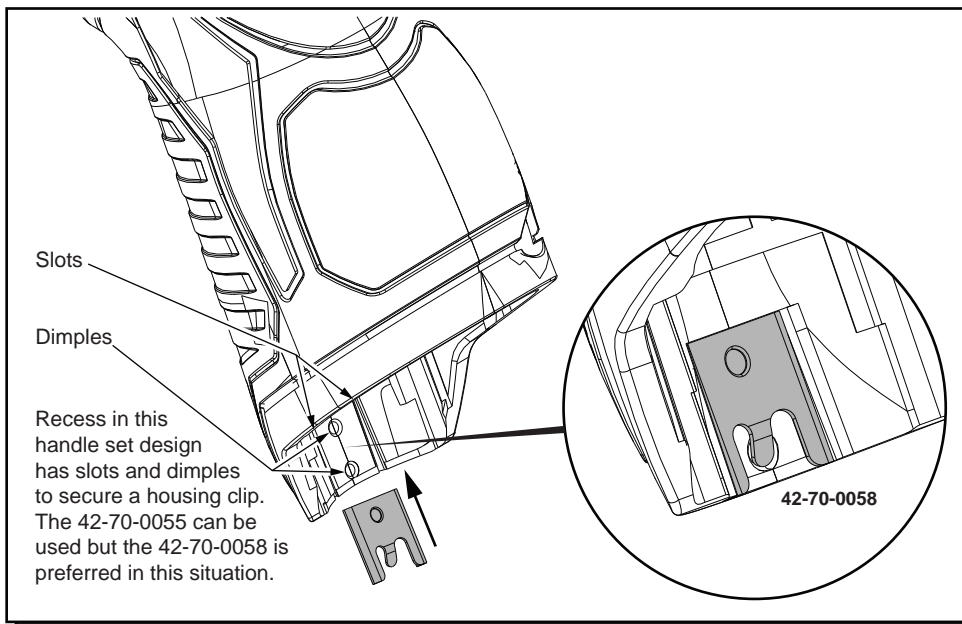

Updated M12™ Handle Sets utilize **Housing Connection Clips No. 42-70-0055 and 42-70-0058. (The 42-70-0058 is a preferred upgrade)**. Install this clip design by aligning the side rails of the clip with the two slots in the handle set. Gently push into place with the aid of a small flat blade screwdriver or a similar instrument. Be sure that the clip is properly seated in both slots and that the tab of the clip snaps down in the round dimpled cavity of the handle set. Be sure that the clip is flush to sub-flush to the end of the handle set. To remove the clip, use the same small flat blade screwdriver or a similar instrument and lift up on the clip tab while pushing the clip out of the handle set. Use a needle nose pliers to gently rebend the clip tab if necessary. If the tab on the clip is damaged during this process and is loose or will not stay in place, replace with a new 42-70-0058 clip.

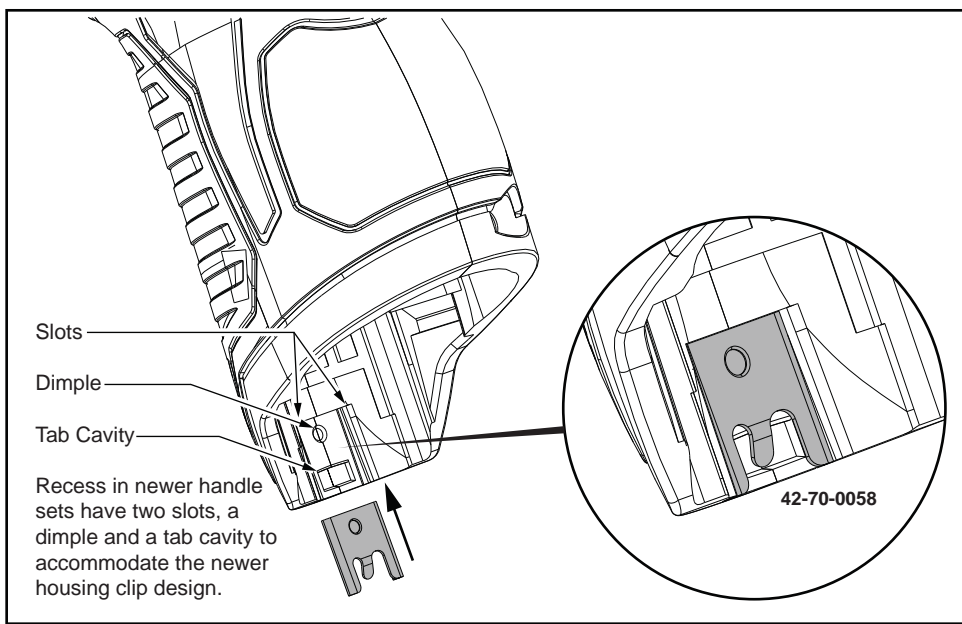

Newer M12™ Handle Sets utilize **Housing Connection Clip No. 42-70-0058**. Install this clip design by aligning the side rails of the clip with the two slots in the handle set. Gently push into place with the aid of a small flat blade screwdriver or a similar instrument. Be sure that the clip is properly seated in both slots and that the tab of the clip snaps down in the rectangular cavity of the handle set. Be sure that the clip is flush to sub-flush to the end of the handle set. To remove the clip, use the same small flat blade screwdriver or a similar instrument and lift the clip tab out of the cavity while pushing the clip out of the handle set. Use a needle nose pliers to gently rebend the clip tab if necessary. If the tab on the clip is damaged during this process and is loose or will not stay in place, replace with a new 42-70-0058 clip.

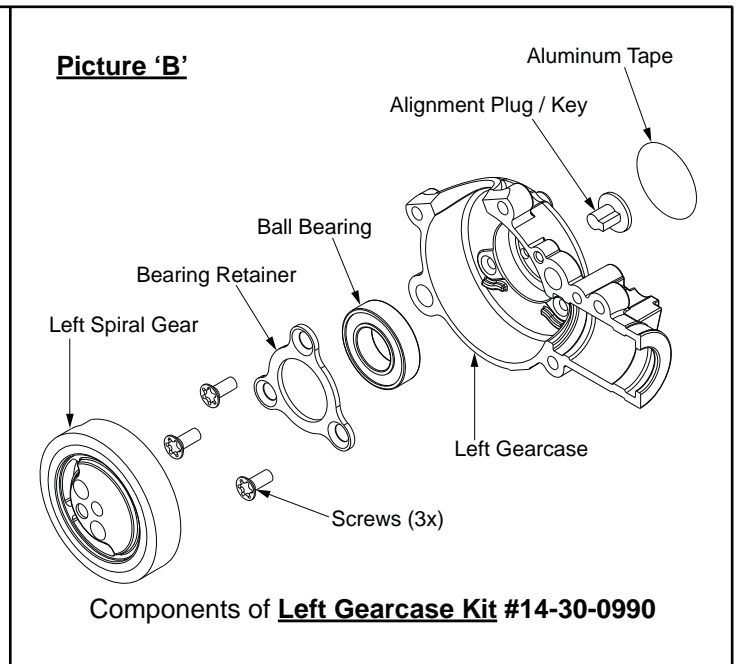
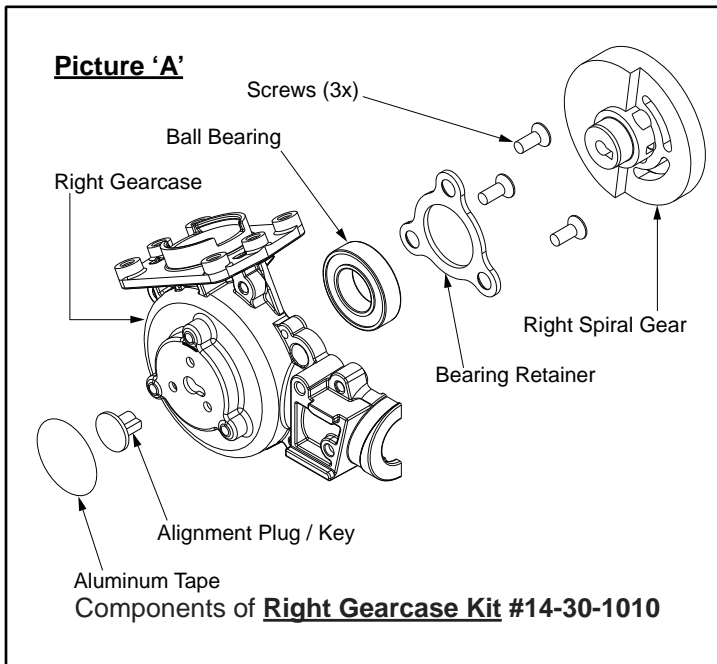

Picture "A and B" show the components that make-up the Right and Left Gearcase kits for M12 FUEL™ Cordless Hackzall® 2520-20. Each kit contains one [1] Alignment Plug / Key and [1] round Aluminum adhesive backed disc (not sold separately) which will be needed when servicing / replacing the gearcase assemblies of the M12 FUEL™ Hackzall®.

The Right and Left helical gear assemblies are supported independently in their respective gearcase assembly and turn independently. Each of the helical gears have a counter weight and when the two gearcase halves are assembled together **gearing must be synchronized to eliminate excessive vibration.**

Synchronization of the two gear case halves can be accomplished by using the Alignment Plug / Key supplied with each gearcase kit. Anytime rotor assembly 16-07-2500 has to be removed from the gearcase halves, helical gears will need to be resynchronized using the alignment plug / keys.

Synchronizing / Assembling Gearcase Kit Assemblies 14-30-1010 – 14-30-0990

Once the **rotor assembly** has been removed from the gearcase assembly the keyway cut into each **helical gear** will no longer be aligned with the **gearcase keyway** (fig. 1) due to the counter balance of the helical gear.

1. Rotate (by hand) **helical gear** in right gearcase (picture "A") until **helical gear keyway** is in-line with the **gearcase keyway** (fig. 2).
2. Install **plug / key** from kit into gearcase / helical gear keyway (fig. 3).
3. Install **drive pin sleeve** onto pin located on right helical gear (coat with type "L" grease).

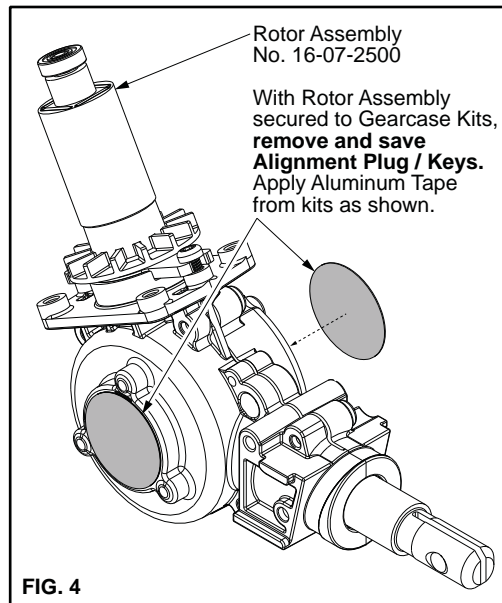
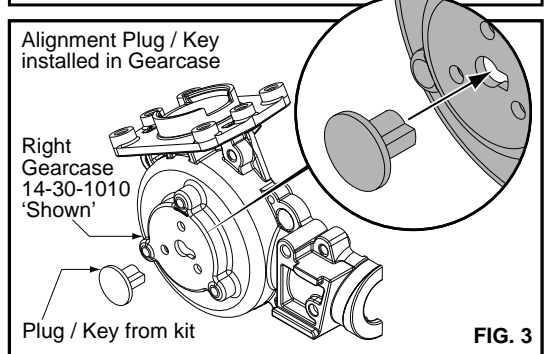
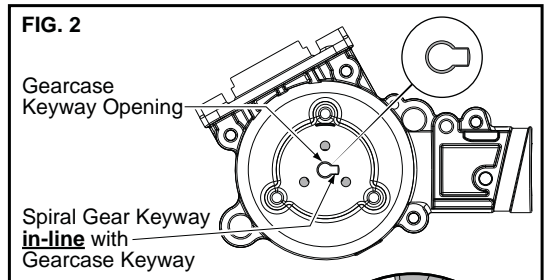
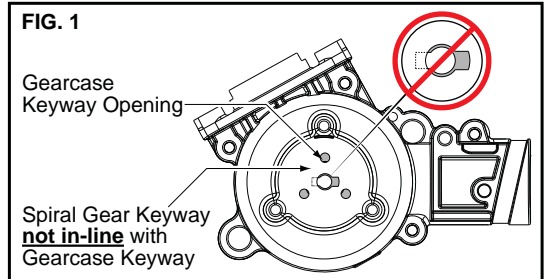

4. Install **spindle / gearcase bushing assembly** into right gearcase (coat components with type "L" grease and make sure spindle lock pin hole faces right gearcase).
Note: If new felt seal is being installed saturate seal with a lightweight oil.
5. Place approximately 1/8oz. Type "L" grease onto teeth of right helical gear. (Set assembly aside).
6. Rotate (by hand) **helical gear** in left gearcase (picture "B") until **helical gear keyway** is in-line with the **gearcase keyway** (fig. 2).
7. Install **plug / key** from kit into gearcase / helical gear keyway (fig. 3).
8. Place approximately 1/8oz. Type "L" grease onto teeth of left helical gear.
9. Assemble lubricated left gearcase assembly onto lubricated right gearcase assembly and install four [4] gearcase screws.
10. Install motor assembly 23-30-0900 and secure to gearcase assembly.
11. Remove left and right alignment plug (s) and apply aluminum tape disc from kits to each side of gearcase (fig.4). **SAVE PLUGS incase motor needs servicing or replacing.**

REMOVING THE STEEL QUIK-LOK® BLADE CLAMP (49)

- Remove external retaining ring (4a) and pull front cam (4b) off.
- Pull lock pin (4c) out and remove remainder of parts and discard.

REASSEMBLY OF THE STEEL QUIK-LOK® BLADE CLAMP (4)

- Coat new lock pin with powdered graphite.
- Hold tool in a vertical position.
- Place spring cover (4g) onto spindle.
- Slide torsion spring (4f) onto spindle with spring leg on hole side of spindle.
- Slide sleeve (4e) onto spindle aligning hole on sleeve with hole in spindle.
- Slide rear cam (4d) over sleeve (4e) until it bottoms on sleeve shoulder, **ensure leg of spring (4f) inserts into inner slot / hole in rear cam (4d).**
- Rotate rear cam in the direction of the arrows located on spring cover until there is clearance for lock pin (4c) to be inserted into sleeve/spindle holes. Insert lock pin.
- Align front cam (4b) inner ribs with rear cam outer slots and slide front cam onto sleeve until it bottoms. Retaining ring groove on the spindle shaft (27) should be completely visible.
- Attach retaining ring (4a) by separating coils and inserting end of ring into groove, then wind remainder of ring into groove. Ensure ring is seated in groove.
- Blade clamp should rotate freely. During normal usage, debris may not allow blade clamp to rotate freely. The use of spray lubricant can help free blade clamp. In extreme conditions, follow these instructions to remove, clean and reassemble blade clamp.

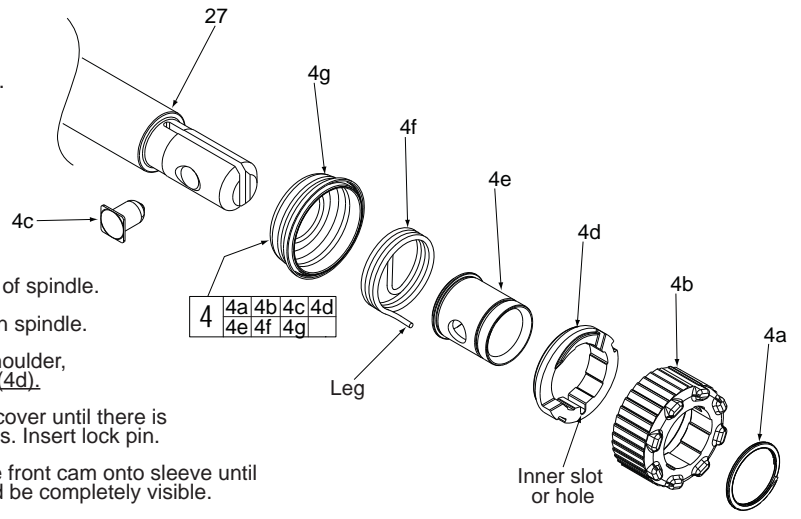

AS AN AID TO REASSEMBLY, TAKE NOTICE OF WIRE ROUTING AND POSITION IN WIRE GUIDES AND TRAPS WHILE DISMANTLING TOOL.

BE CAREFUL AND AVOID PINCHING WIRES BETWEEN HANDLE HALVES WHEN ASSEMBLING.

