



# SERVICE PARTS LIST

BULLETIN NO.  
54-06-0480

SPECIFY CATALOG NO. AND SERIAL NO. WHEN ORDERING PARTS		REVISED BULLETIN
<b>M12™ FUEL™ Multi-Head Drill</b>		
CATALOG NO.	<b>2505-20</b>	STARTING SERIAL NO. <b>K81A</b>

**EXAMPLE:**  

00	0
----	---

 Component Parts (Small #) Are Included  
 When Ordering The Assembly (Large #).

FIG.	PART NO.	DESCRIPTION	SEATING TORQUE (IN-LBS)
12	06-82-2500	8-32 x 7mm Pan Hd. T-15 Machine Screw	5-7
15	06-82-5315	M3 x 26.5mm Pan Hd. ST T-10 Screw	6-8
16	06-82-1080	M3 x 14mm Pan Hd. ST T-10 Screw	5-7

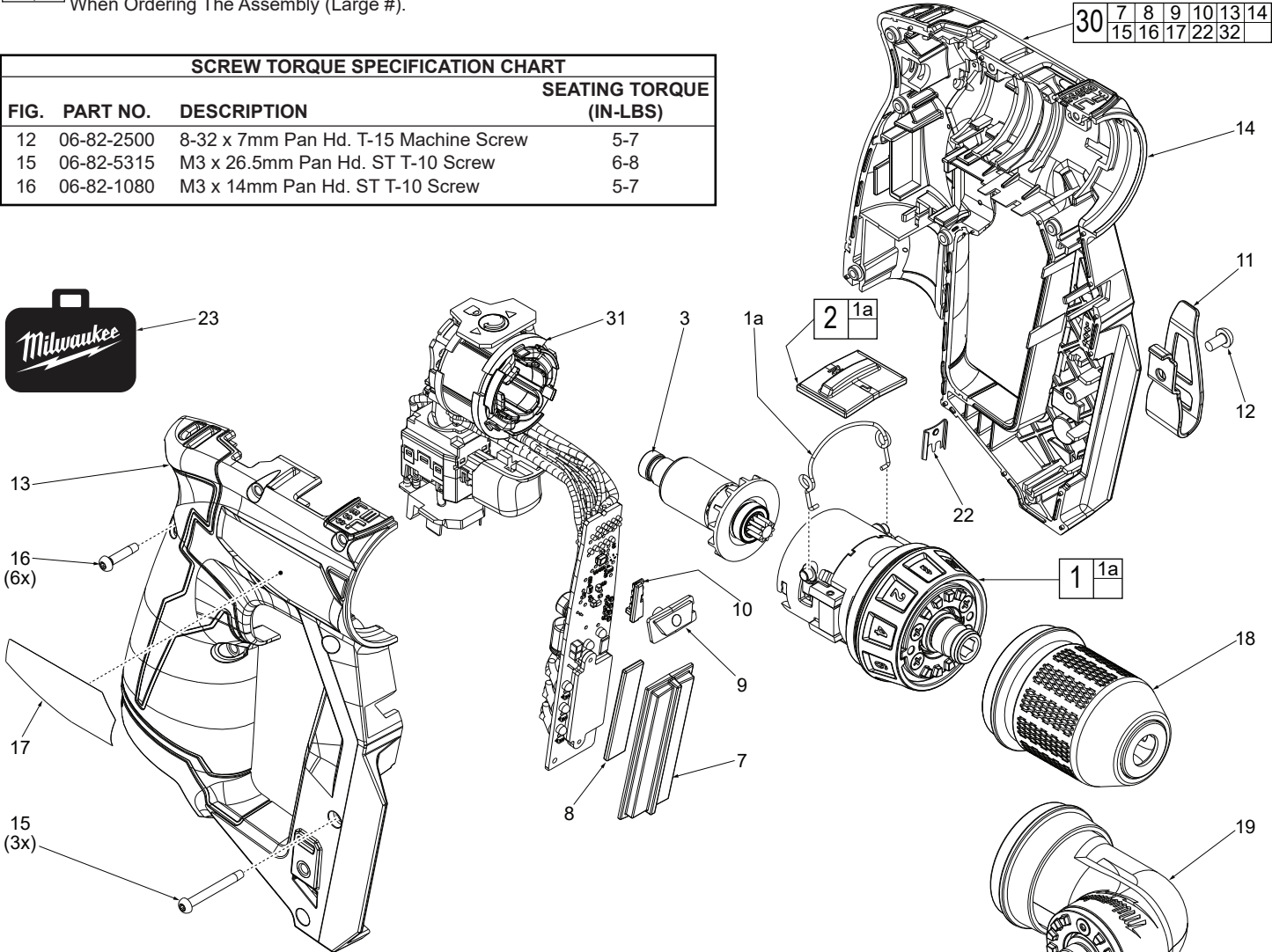
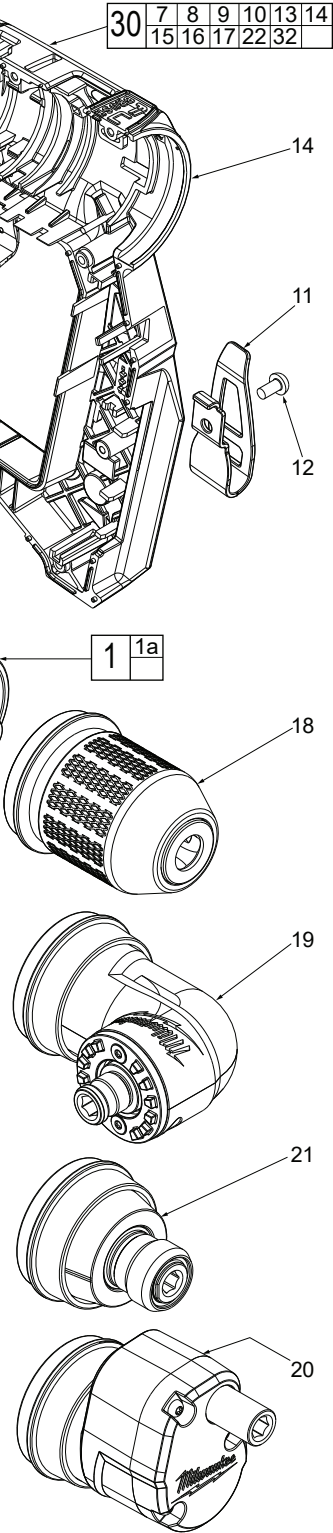
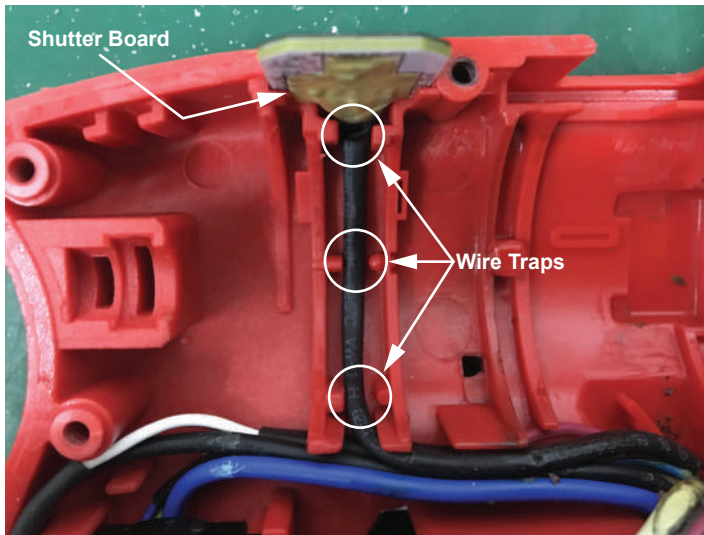

FIG.	PART NO.	DESCRIPTION OF PART	NO. REQ.
1	14-29-2505	Gear Box with Clutch Assembly	(1)
1a	44-10-0196	Speed Selector Lever	(1)
2	45-24-0231	Speed Selector Slide Kit	(1)
3	16-01-2504	Rotor Assembly	(1)
7	-----	Magnet Bit Holder	(1)
8	-----	Magnet	(1)
9	-----	LED Lens	(1)
10	-----	Light Pipe	(1)
11	42-70-0095	Belt Clip	(1)
12	06-82-2500	8-32 x 7mm Pan Hd. T-15 Machine Screw	(1)
13	-----	Housing Cover-Right	(1)
14	-----	Housing Support-Left	(1)
15	06-82-5315	M3 x 26.5mm Pan Hd. ST T-10 Screw	(3)
16	06-82-1080	M3 x 14mm Pan Hd. ST T-10 Screw	(6)
17	12-20-2512	Service Nameplate	(1)
18	42-66-0019	Removable 3/8" Keyless Chuck	(1)
19	14-72-0100	Removable Right Angle Drive (RAD)	(1)
20	14-35-0150	Removable Offset Attachment	(1)
21	14-35-0155	Removable Hex Attachment	(1)
22	42-70-0058	Housing Clip	(1)
23	42-55-2501	Zippered Tool Bag	(1)
30	31-44-2504	Housing Assembly	(1)
31	14-20-2505	Electronics Assembly	(1)
32	10-20-3098	Warning Label (Not Shown)	(1)



## WIRING INSTRUCTIONS



Tuck Shutter Board squarely and firmly in slotted recess of housing support. Push wires completely down in wire traps.

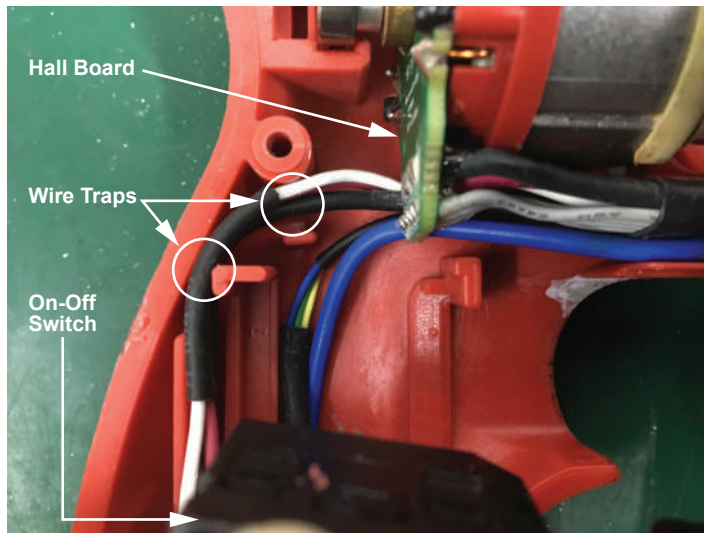

Push black and white wires completely down in wire traps. Route blue and yellow wires behind on-off switch.

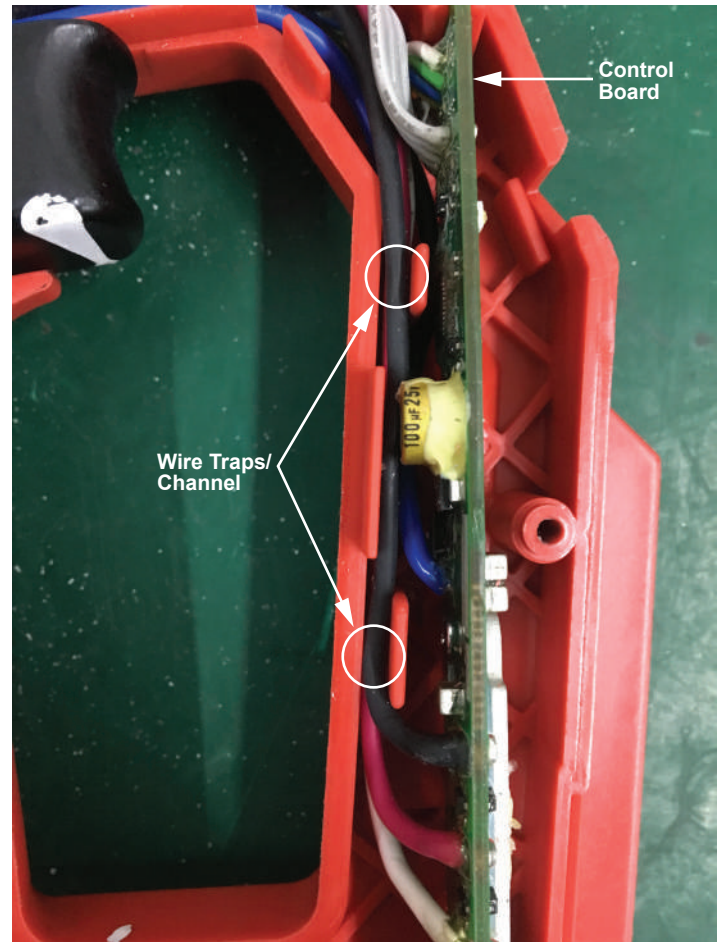

Route all control board wires through wire traps/channel as shown. Be sure to push wires completely down in traps. Be sure control board is seated squarely and firmly in support housing.

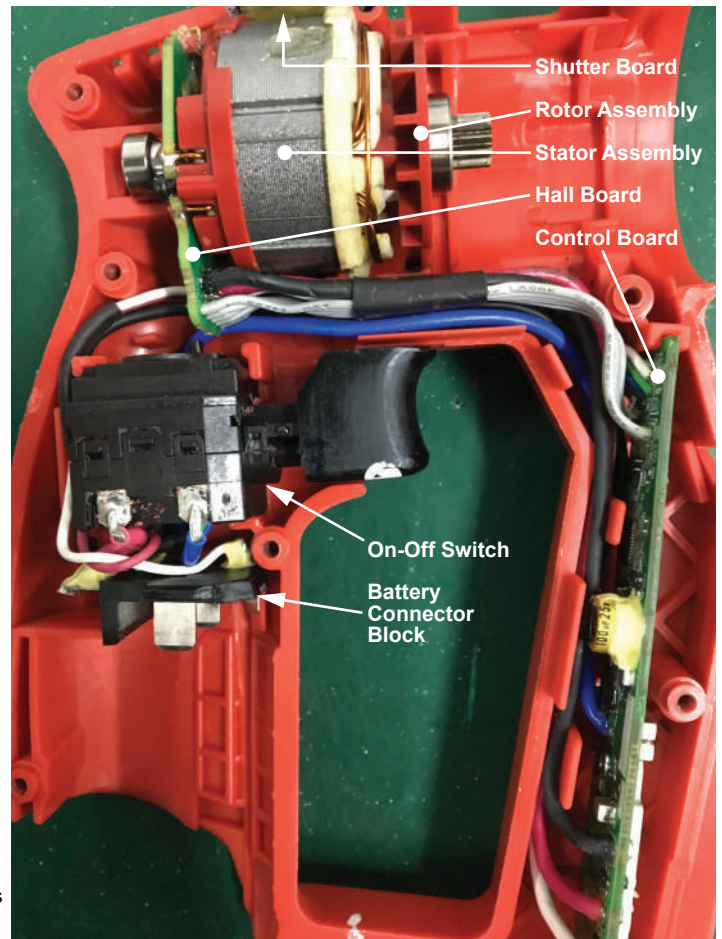

Be sure all elements of the electronics assembly are firmly seated in the support housing. Be sure all wires are pushed completely down in wire traps and channels. Make sure there is no interference prior to installing the housing cover.