



SERVICE PARTS LIST

BULLETIN NO.
54-47-0350

SPECIFY CATALOG NO. AND SERIAL NO. WHEN ORDERING PARTS		REVISED BULLETIN	DATE
M12 SOLDERING IRON			July 2017
CATALOG NO.	2488-20	WIRING INSTRUCTION	
STARTING SERIAL NO.	H97A		

EXAMPLE:
Component Parts (Small #)
Are Included When Ordering
The Assembly (Large #).

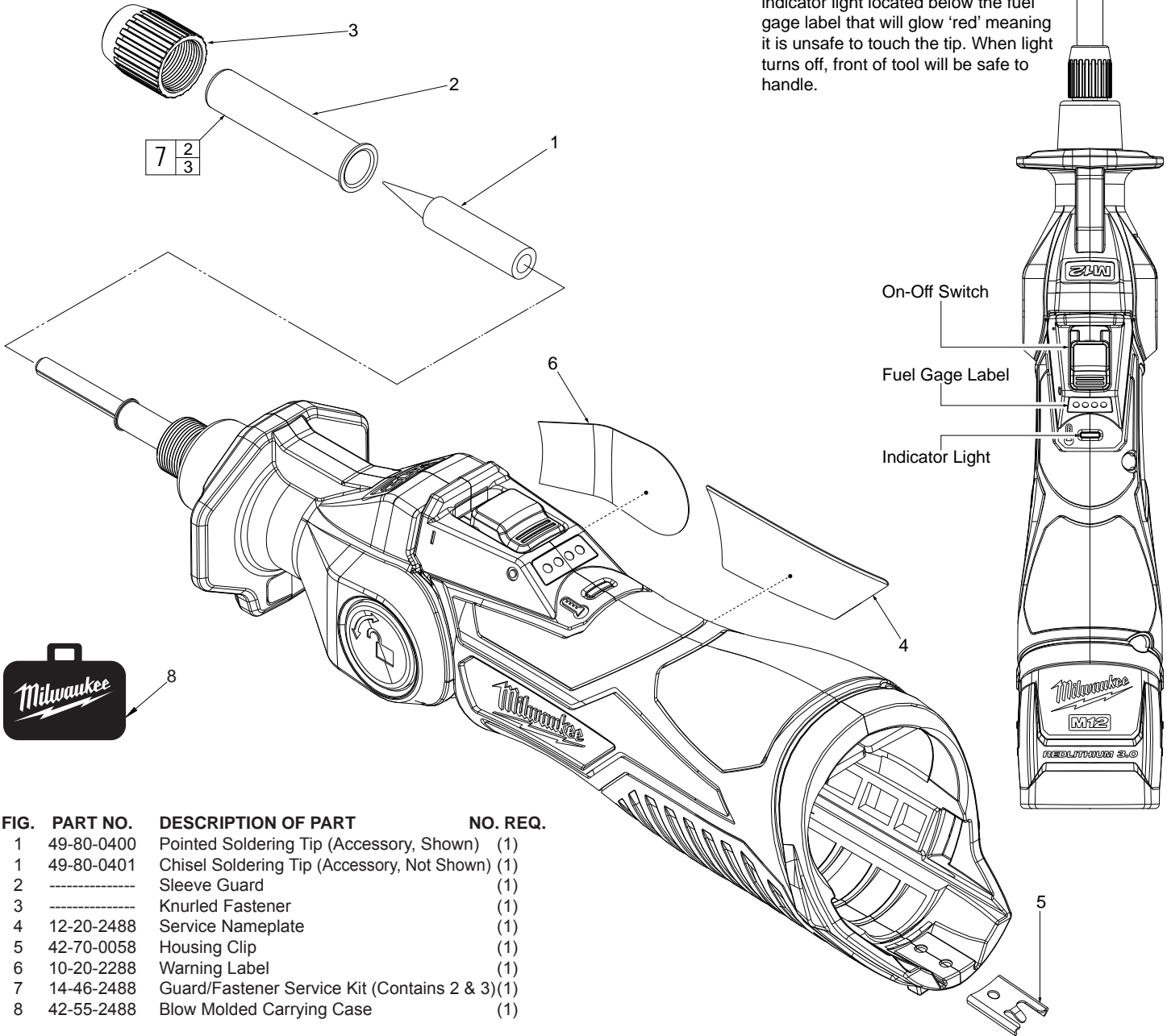

FIG.	PART NO.	DESCRIPTION OF PART	NO. REQ.
1	49-80-0400	Pointed Soldering Tip (Accessory, Shown)	(1)
1	49-80-0401	Chisel Soldering Tip (Accessory, Not Shown)	(1)
2	-----	Sleeve Guard	(1)
3	-----	Knurled Fastener	(1)
4	12-20-2488	Service Nameplate	(1)
5	42-70-0058	Housing Clip	(1)
6	10-20-2288	Warning Label	(1)
7	14-46-2488	Guard/Fastener Service Kit (Contains 2 & 3)	(1)
8	42-55-2488	Blow Molded Carrying Case	(1)

FIG. NOTES

4.6 A clean, dry surface is essential for proper performance for any adhesive system. The area intended for application of any adhesive label or nameplate must be prepared by cleaning with isopropyl alcohol. The solvent is to be applied with a clean, lint free applicator and the surface allowed to dry before applying the label or nameplate.