



SERVICE PARTS LIST

BULLETIN NO.
54-22-2100

SPECIFY CATALOG NO. AND SERIAL NO. WHEN ORDERING PARTS		REVISED BULLETIN	DATE
M12 FUEL™ Die Grinder			June 2019
CATALOG NO.	2485-20	STARTING SERIAL NO.	K92A
WIRING INSTRUCTION			

NOTE: Damper is pressed in-between housing halves.

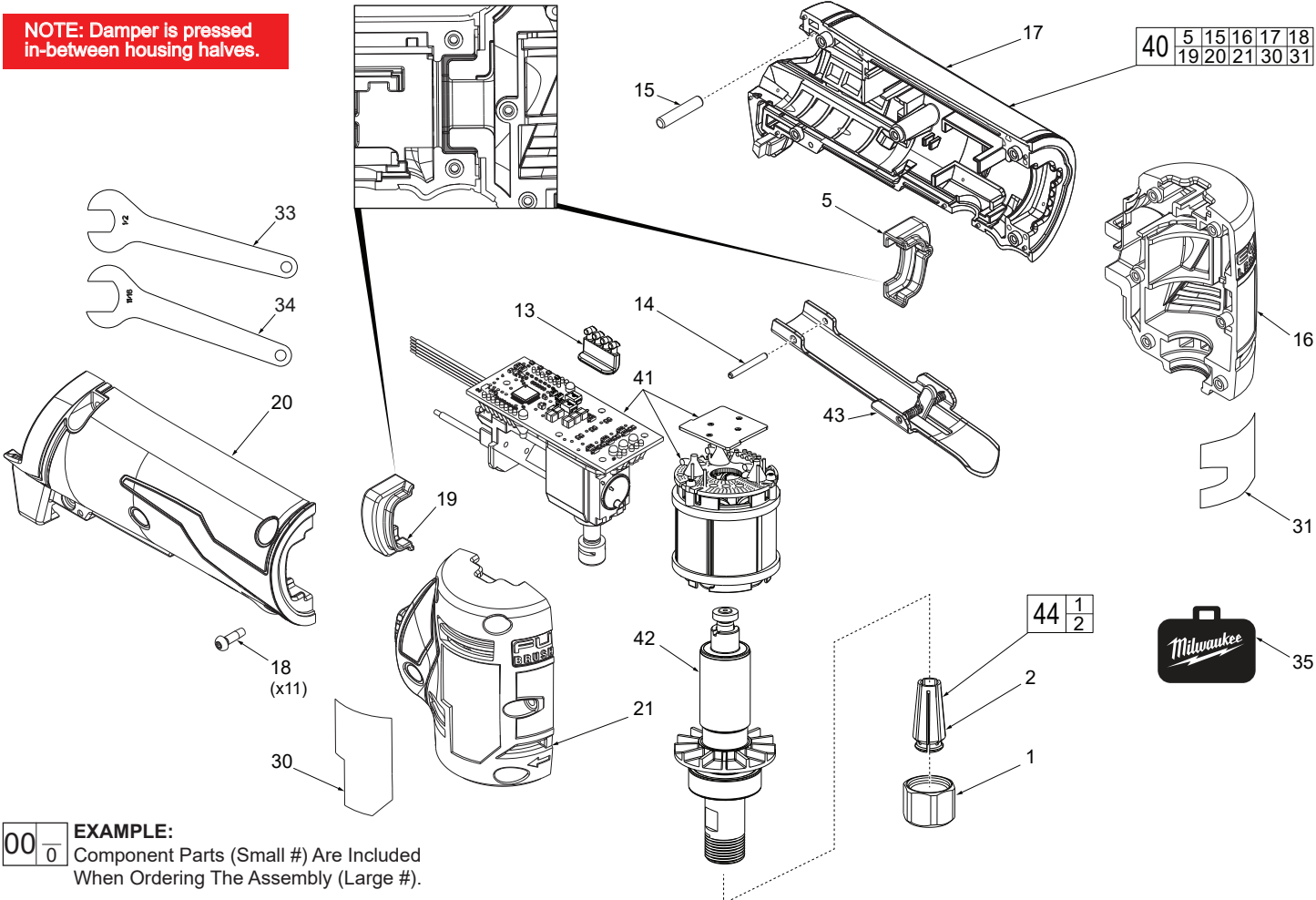

EXAMPLE:
00 0 Component Parts (Small #) Are Included When Ordering The Assembly (Large #).

FIG.	PART NO.	DESCRIPTION OF PART	NO. REQ.
1	48-68-0031	Collet Nut	1
2	48-66-0974	1/4" Collet	1
5	-----	Damper for Support	1
13	23-28-0340	Light Pipe	1
14	44-60-0575	Rivet Pin for Housing	1
15	44-94-0050	Rod	1
16	-----	Housing Support Head	1
17	-----	Housing Support Grip	1
18	06-82-3002	Housing Screw	11
19	-----	Damper for Cover	1
20	-----	Housing Cover Grip	1
21	-----	Housing Cover Head	1
30	12-20-2430	Service Nameplate	1
31	10-20-0625	Warning Label	1
32	42-77-0405	1/8" Collet (Optional) Not Shown	1
33	49-96-4040	Open End Wrench (1/2")	1
34	49-96-4090	Open End Wrench (11/16")	1
35	42-55-2425	Contact Bag	1
40	14-34-0002	Housing Kit	1
41	14-20-0070	Electronics Assembly	1
42	16-01-2405	Rotor Assembly	1
43	44-10-0520	Paddle Trigger Assembly	1
44	14-46-0166	1/4" Collet and Nut Kit	1

Install the electronics assembly, route wires through wire traps and channels as shown. Be sure all components are seated squarely and firmly in place. Be sure there is no interference when installing the housing covers (20, 21).

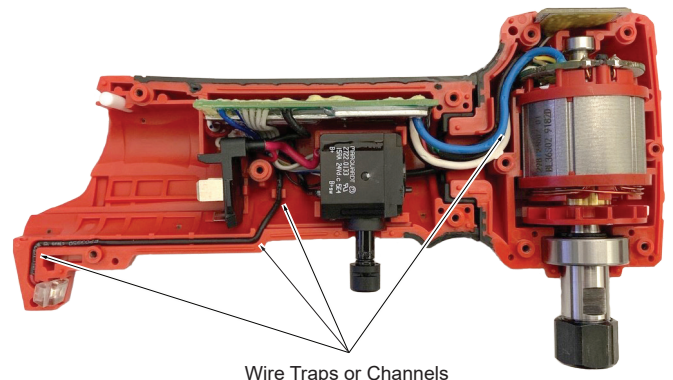

SCREW TORQUE SPECIFICATIONS				
FIG.	PART NO.	WHERE USED	SEAT TORQUE	
			(KG/CM)	(IN/LBS)
18	06-82-3002	Housing Cover Head	7-9	6.0-7.8
18	06-82-3002	Housing Cover Grip	7-9	6.0-7.8