



# SERVICE PARTS LIST

BULLETIN NO.  
54-40-2445

SPECIFY CATALOG NO. AND SERIAL NO. WHEN ORDERING PARTS		REVISED BULLETIN	DATE
<b>M12™ JIG SAW</b>			
<b>CATALOG NO.</b>	<b>2445-20</b>	<b>STARTING SERIAL NO.</b>	<b>D58A</b>
		<b>WIRING INSTRUCTION SEE PAGE 4</b>	

**EXAMPLE:**  

00	0
----	---

 Component Parts (Small #) Are Included When Ordering The Assembly (Large #).

FIG.	PART NO.	DESCRIPTION OF PART	NO. REQ.
2	45-22-0970	Barrel Cam	(1)
3	40-50-1810	Spring	(1)
12	05-81-1190	M3.5 x 10mm Screw	(4)
13	42-92-1170	Spindle Bushing Cover	(1)
15	42-24-0700	Spindle Bushing	(1)
16	42-40-1200	Spindle Roller Bushing	(1)

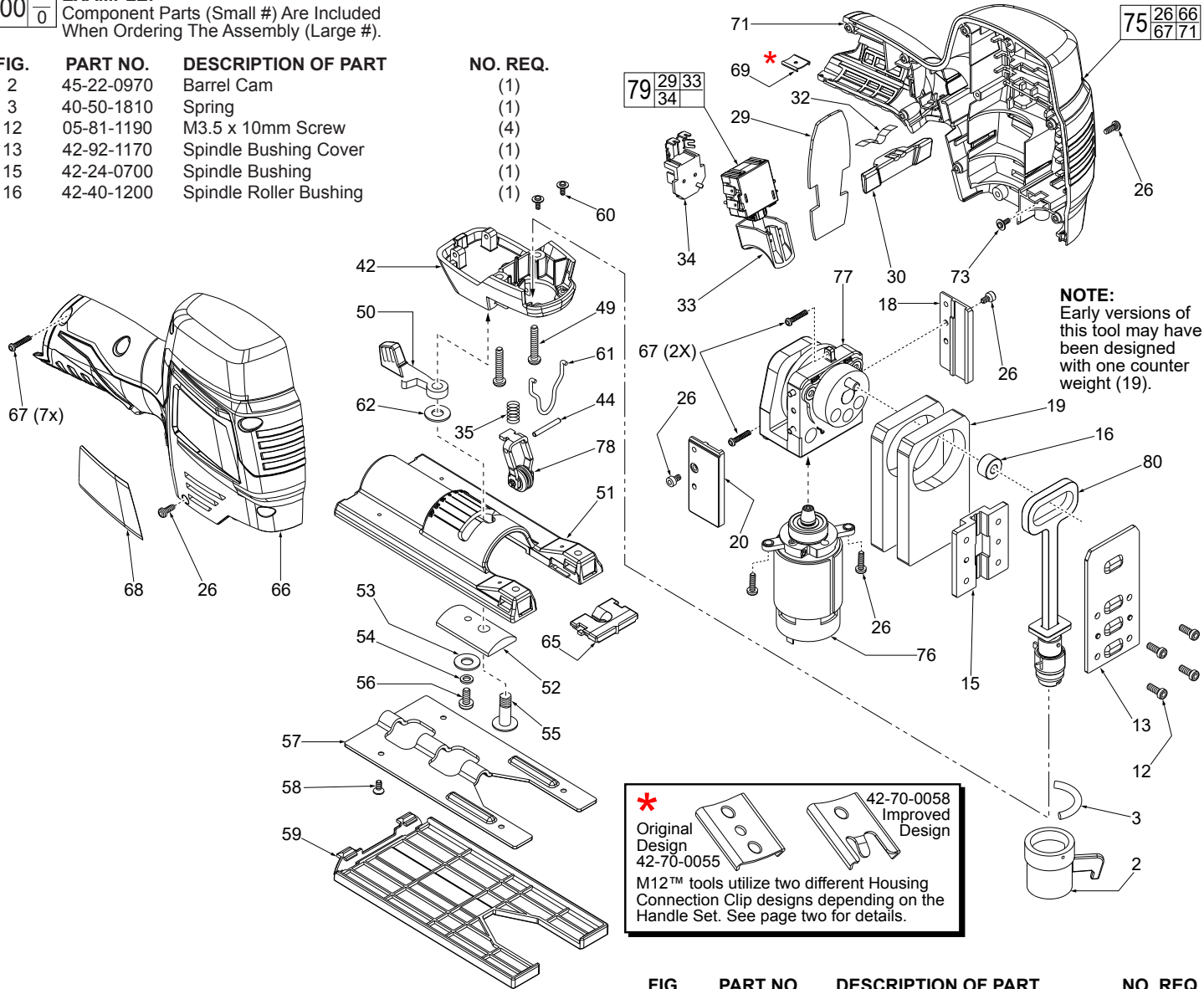
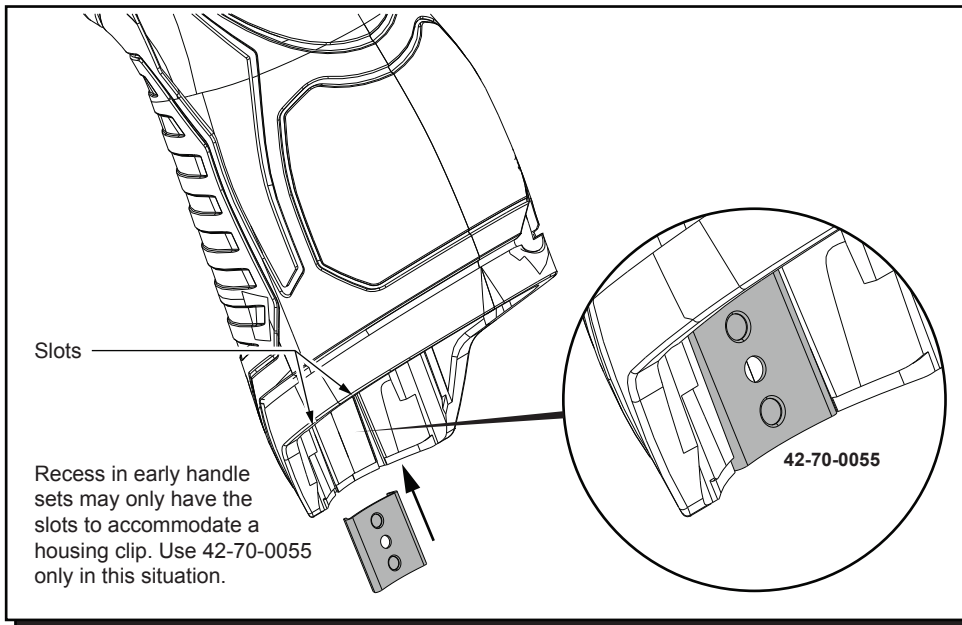

FIG.	PART NO.	DESCRIPTION OF PART	NO. REQ.
18	42-24-0720	Counter Weight Bushing - Left	(1)
19	42-28-0530	Counter Weight (See note above)	(1 or 2)
20	42-24-0710	Counter Weight Bushing - Right	(1)
26	05-86-1000	M3 x 8mm T-10 Screw	(6)
29	-----	PCB Assembly	(1)
30	42-42-1010	Lockout Lever	(1)
32	40-50-0027	Spring Plate	(1)
33	-----	Switch	(1)
34	-----	Battery Connector Block	(1)
35	40-50-1830	Roller Bracket Spring	(1)
42	28-14-1030	Lower Housing	(1)
44	06-65-1390	2.5 x 22mm Pin	(1)
49	05-81-1210	M4 x 22mm Screw	(2)
50	44-10-0780	Shoe Release Lever	(1)
51	28-06-0850	Shoe Body	(1)
52	31-17-0600	Shoe Clamp	(1)
53	45-88-2160	Flat Washer	(1)
54	45-88-1890	Spring Washer	(1)
55	05-74-2000	1/4-20 x .75" UNC-2A Screw	(1)
56	05-81-1030	M4 x 9mm T-20 Screw	(1)

FIG.	PART NO.	DESCRIPTION OF PART	NO. REQ.
57	42-92-1180	Shoe Insert	(1)
58	05-81-1205	M3 x 0.5 x 7mm Screw	(4)
59	31-15-1600	Shoe Base Cover	(1)
60	05-81-1290	M2.3 x 0.4 Screw	(2)
61	23-94-2400	Guard Wire	(1)
62	45-88-2130	Flat Washer	(1)
65	43-84-1030	Anti-Splintering Device	(1)
66	-----	Housing Halve - Right	(1)
67	06-82-1080	M3 x 14mm T-10 Screw	(9)
68	12-20-2445	Service Nameplate	(1)
69	42-70-0058	Housing Connection Clip	(1)
71	-----	Housing Halve - Left	(1)
73	05-81-1195	M3 x 8mm Screw	(1)
75	31-44-2675	Housing Set with Screws	(1)
76	23-30-0875	Motor Assembly	(1)
77	28-90-0350	Gearbox and Cam Assembly	(1)
78	42-36-1060	Roller Bracket Assembly	(1)
79	23-66-3140	Switch Assembly	(1)
80	38-50-2730	Spindle Assembly	(1)

MILWAUKEE ELECTRIC TOOL CORPORATION



Early M12™ Handle Sets utilize **Housing Connection Clip No. 42-70-0055**. Install this clip design by aligning the side rails of the clip with the two slots in the handle set. Gently push into place with the aid of a small flat blade screwdriver or a similar instrument. Be sure that the clip is properly seated in both slots and that the clip is flush to sub-flush to the end of the handle set. To remove the clip, use the same small flat blade screwdriver or a similar instrument and push the clip out of the handle set. If the clip is loose or will not stay in place, a needle nose pliers can be used to gently bend/pinch the side rails of the clip. If the clip is damaged do not use, replace with a new 42-70-0055 housing clip.

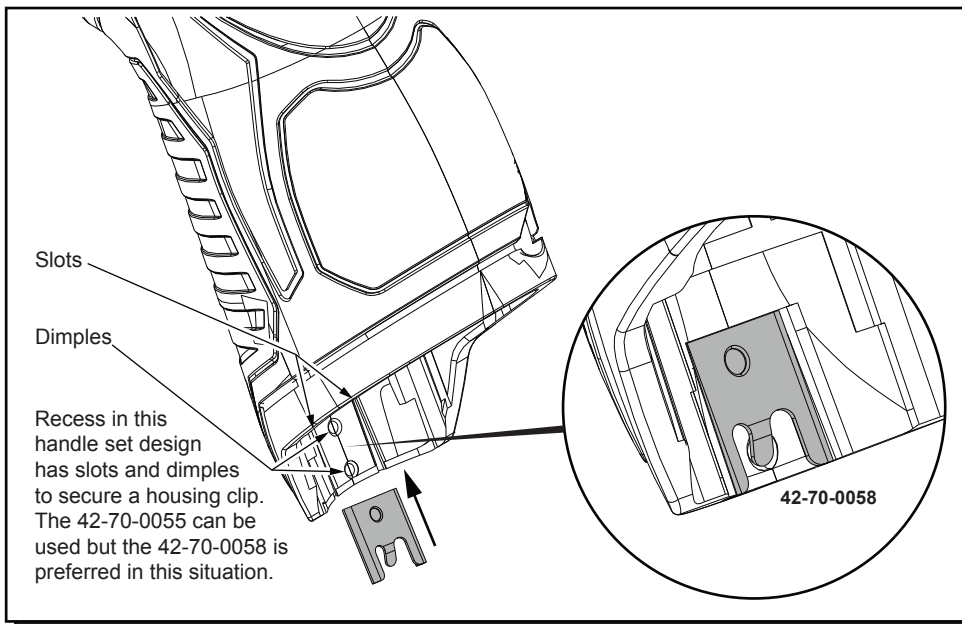

Updated M12™ Handle Sets utilize **Housing Connection Clips No. 42-70-0055 and 42-70-0058. (The 42-70-0058 is a preferred upgrade)**. Install this clip design by aligning the side rails of the clip with the two slots in the handle set. Gently push into place with the aid of a small flat blade screwdriver or a similar instrument. Be sure that the clip is properly seated in both slots and that the tab of the clip snaps down in the round dimpled cavity of the handle set. Be sure that the clip is flush to sub-flush to the end of the handle set. To remove the clip, use the same small flat blade screwdriver or a similar instrument and lift up on the clip tab while pushing the clip out of the handle set. Use a needle nose pliers to gently rebend the clip tab if necessary. If the tab on the clip is damaged during this process and is loose or will not stay in place, replace with a new 42-70-0058 clip.

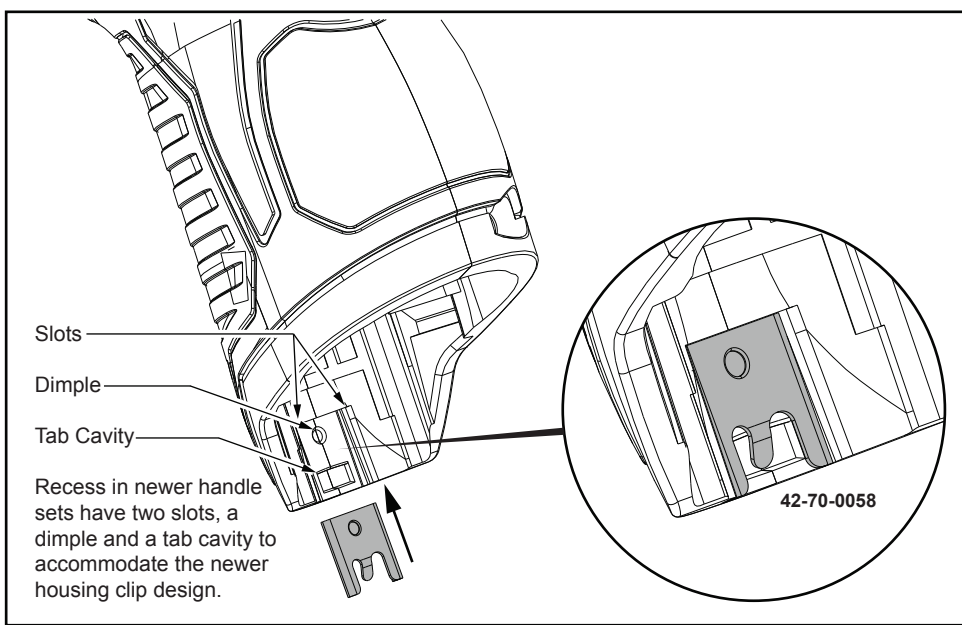

Newer M12™ Handle Sets utilize **Housing Connection Clip No. 42-70-0058**. Install this clip design by aligning the side rails of the clip with the two slots in the handle set. Gently push into place with the aid of a small flat blade screwdriver or a similar instrument. Be sure that the clip is properly seated in both slots and that the tab of the clip snaps down in the rectangular cavity of the handle set. Be sure that the clip is flush to sub-flush to the end of the handle set. To remove the clip, use the same small flat blade screwdriver or a similar instrument and lift the clip tab out of the cavity while pushing the clip out of the handle set. Use a needle nose pliers to gently rebend the clip tab if necessary. If the tab on the clip is damaged during this process and is loose or will not stay in place, replace with a new 42-70-0058 clip.

**LUBRICATION NOTES:****Use Type 'J' Grease, No. 49-08-4220**

When servicing, remove 90-95% of the existing grease prior to installing Type "J". Original grease maybe similar in color but not compatible with "J".

- Ⓐ Prior to installing spindle mechanism, distribute approximately 1/4oz. total of grease in each housing half groove that supports the spindle bushing cover (13) and the spindle bushing (15). Coat the felt seal assembly (component of the spindle assembly (80) with grease.
- Ⓑ Prior to assembly, place a heavy coat of grease over the shaft and the orbit slot portions of the spindle assembly (80). Coat the spindle roller bushing (16) and the cam pin with grease. Place grease in the spindle slots of the spindle bushing cover (13) and the spindle bushing (15).
- Ⓒ Prior to assembly, coat with grease the cam of the gearcase and cam assembly (77). Coat the inner slots of the counter weight bushings (18 and 20) with grease.
- Ⓓ Place approximately 1/4oz. of grease in the middle of the gearbox and cam assembly (77) making sure that the gear and pinion teeth are completely coated.

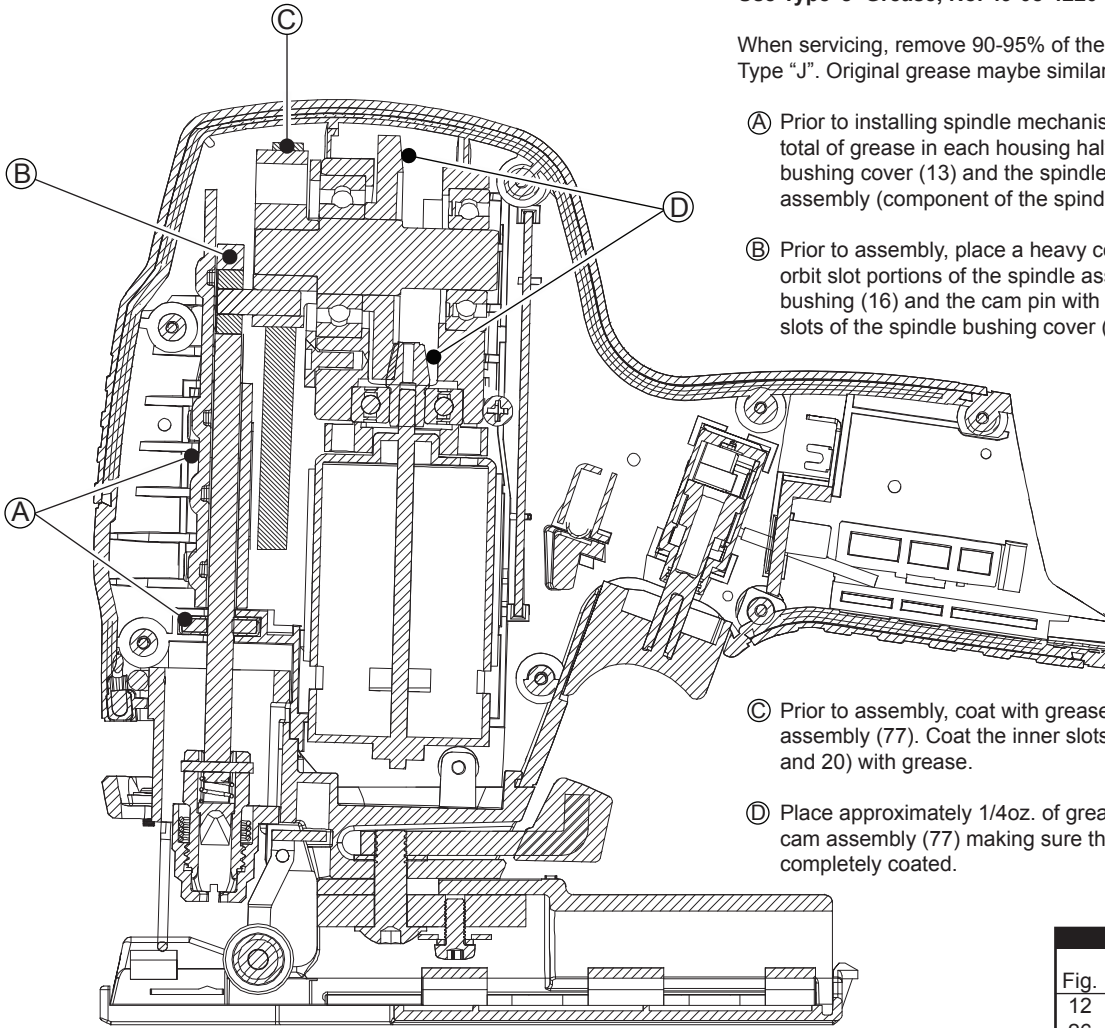
**TORQUE SPECIFICATIONS**

Fig.	Part No.	Min. (In-Lbs)	Max. (In-Lbs)
12	05-81-1190	13	16
26	05-86-1000	6	8
49	05-81-1210	11	14
55	05-74-2000	21	30
56	05-81-1030	14	16
58	05-81-1205	3	6
60	05-81-1290	2	5
73	05-81-1195	2	4

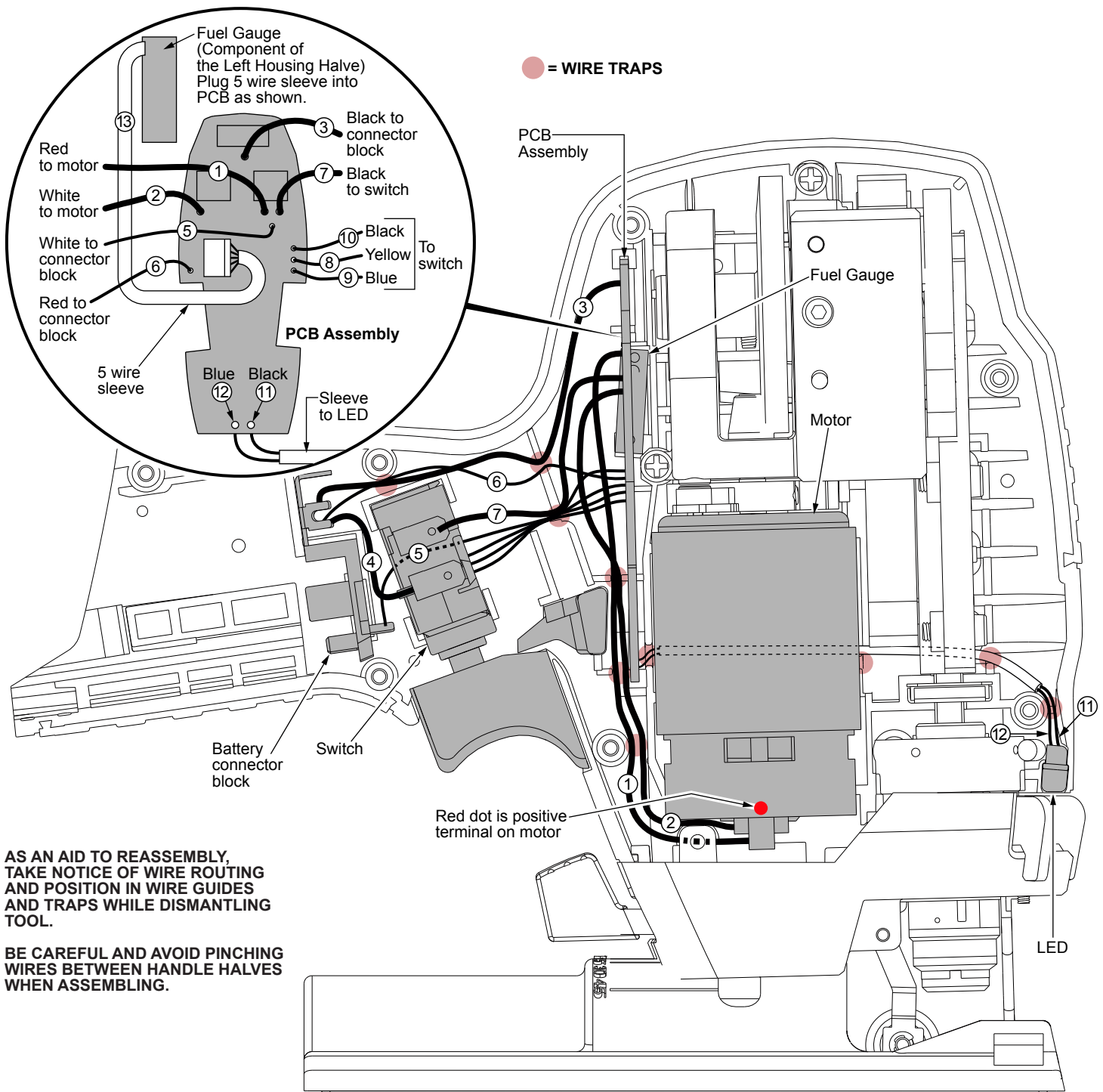

### WIRING SPECIFICATIONS

Wire No.	Wire Color	Origin or Gauge	Length	Terminals, Connectors and 1 or 2 End Wire Preparation
1	Red	23-66-3140	----	Component of the switch assembly. Route from PCBA and solder to motor terminal with red dot.
2	White	23-66-3140	----	Component of the switch assembly. Route from PCBA and solder to the other motor terminal.
3	Black	23-66-3140	----	Component of the switch assembly. Runs from PCBA to the battery connector block.
4	Red	23-66-3140	----	Component of the switch assembly. Runs from switch to the battery connector block.
5	White	23-66-3140	----	Component of the switch assembly. Runs from PCBA to the battery connector block.
6	Red	23-66-3140	----	Component of the switch assembly. Runs from PCBA to the battery connector block.
7	Black	23-66-3140	----	Component of the switch assembly. Runs from PCBA to the switch.
8	Yellow	23-66-3140	----	Component of the switch assembly. Runs from PCBA to the switch.
9	Blue	23-66-3140	----	Component of the switch assembly. Runs from PCBA to the switch.
10	Black	23-66-3140	----	Component of the switch assembly. Runs from PCBA to the switch.
11	Black	23-66-3140	----	Component of the switch assembly. Sleeved with #12 and runs from PCBA to the LED.
12	Blue	23-66-3140	----	Component of the switch assembly. Sleeved with #11 and runs from PCBA to the LED.
13	5 wires	31-44-2675	----	Component of the housing set (specifically the left halve). Plug 5 wire harness into PCBA as shown.