



SERVICE PARTS LIST

BULLETIN NO.
54-06-2130

SPECIFY CATALOG NO. AND SERIAL NO. WHEN ORDERING PARTS		REVISED BULLETIN	DATE
M18™ ROCKET™ LED TOWER LIGHT			May 2016
CATALOG NO.	2130-20	STARTING SERIAL NO.	G96A
		WIRING INSTRUCTION	

EXAMPLE:
Component Parts (Small #)
Are Included When Ordering
The Assembly (Large #).

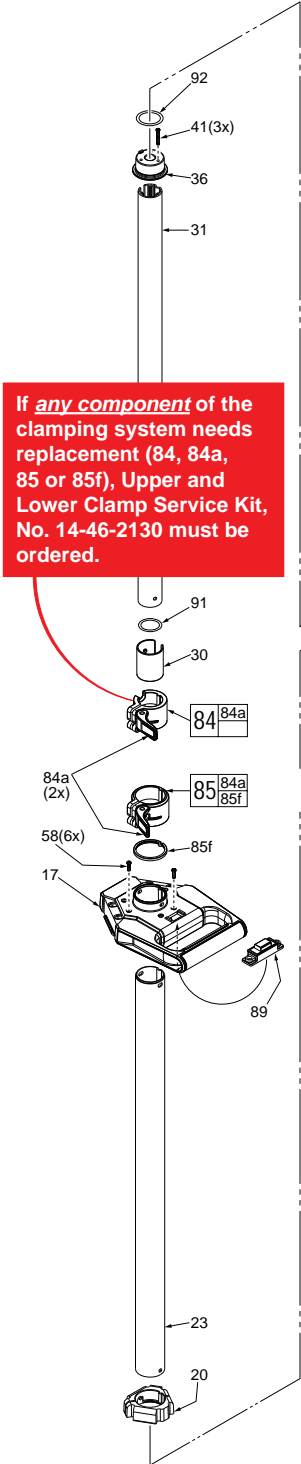

If **any component** of the clamping system needs replacement (84, 84a, 85 or 85f), Upper and Lower Clamp Service Kit, No. 14-46-2130 must be ordered.

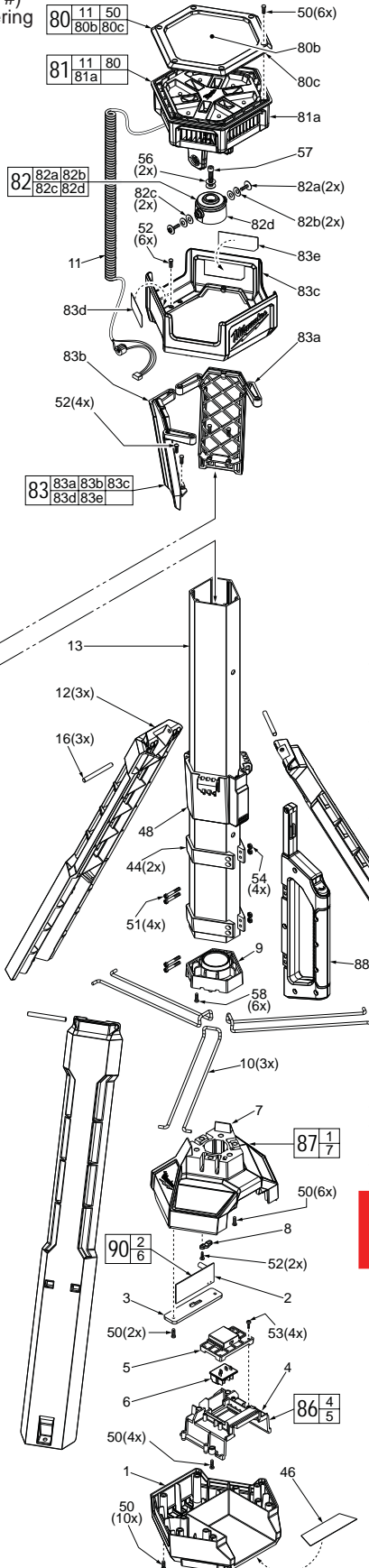
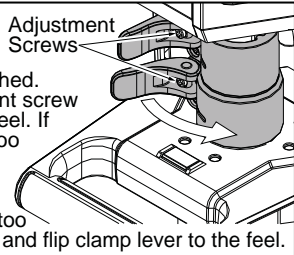

FIG.	PART NO.	DESCRIPTION OF PART	NO. REQ.
1	-----	Electronics Housing - Lower	(1)
2	-----	PCBA	(1)
3	-----	PCBA Retaining Plate	(1)
4	-----	Battery Connector Housing - Lower	(1)
5	-----	Battery Connector Housing - Upper	(1)
6	-----	Battery Connector	(1)
7	-----	Electronics Housing - Upper	(1)
8	31-17-0021	Cord Clamp	(1)
9	31-12-0027	Main Support Tube Lower Cap	(1)
10	44-14-0240	Wire Leg Linkage	(3)
11	-----	Power Cord with Ferrite Bead	(1)
12	44-04-0105	Support Leg	(3)
13	42-78-0200	Main Support Column	(1)
16	44-60-1655	Leg Support Pin	(3)
17	43-62-0395	Switch Handle Support (less switch)	(1)
20	45-60-0045	Large Tube Base Support	(1)
23	45-76-0115	Large Tube	(1)
30	42-40-0005	Small Tube Slide Bushing	(1)
31	45-76-0125	Small Tube	(1)
36	42-52-0007	LED Mounting Cap Support with Nut	(1)
41	06-82-0069	M3.0 x 30 Pan Hd. ST T-10 Screw	(3)
44	45-56-0110	Sliding Handle Guide Strap	(2)
46	12-20-2130	Service Nameplate	(1)
48	42-36-0027	M18™ Leg Support Bracket	(1)
50	06-82-0019	3.5 x 14 Pan Hd. ST T-15 Screw	(28)
51	06-82-0059	M4.0 x 27.5 Pan Hd. T-20 Machine Screw	(4)
52	06-82-0039	M3.5 x 12 Pan Hd. ST T-15 Screw	(12)
53	06-82-0049	3.0 x 12 Pan Hd. ST T-10 Screw	(4)
54	44-40-0485	M4 Nut	(4)
56	45-88-0202	Washer	(3)
57	06-75-0006	M6 Hex Socket Machine Screw	(1)
58	06-82-0029	3.5 x 20 Pan Hd. ST T-15 Screw	(12)
80	44-06-0102	Lens Cover Assembly	(1)
80b	-----	LED Lens Cover	(1)
80c	-----	LED Lens	(1)
81	23-26-0200	LED Light Assembly w/ Power Cord and Grommet	(1)
81a	-----	LED Light Assembly	(1)
82	42-52-0505	LED Mounting Cap w/ Washers and Screws	(1)
82a	-----	PH2 Round Head Washer Screw	(2)
82b	-----	Spring Washer	(2)
82c	-----	Washer	(2)
82d	-----	Mounting Cap	(1)
83	31-55-0075	LED Shroud Assembly	(1)
83a	-----	Shroud Support - Right	(1)
83b	-----	Shroud Support - Left	(1)
83c	-----	LED Shroud	(1)
83d	10-20-1018	Warning Label - Left	(1)
83e	10-20-1019	Warning Label - Right	(1)
84	-----	Small Tube Clamp Assembly	(1)
84a	-----	Clamp Lever	(2)
85	-----	Large Tube Clamp Assembly	(1)
85f	-----	Gasket	(1)
86	43-76-0010	Battery Connector Housing Kit	(1)
87	43-76-0015	Electronics Housing Kit	(1)
88	31-44-0347	Sliding Handle Assembly	(1)
89	23-66-0063	Switch Box Assembly	(1)
90	14-20-2130	Electronics Assembly with Ferrite Bead	(1)
91	34-40-0355	O-Ring	(1)
92	34-40-0357	O-Ring	(1)

Adjustments may be needed to Clamping Assemblies 84 and 85 to prohibit sliding when latched. Tighten or loosen adjustment screw and flip clamp lever to the feel. If clamping the lever seems too difficult **do not force lever**. Screw should be loosened slightly and try securing the lever again. If lever seems too loose, tighten screw slightly and flip clamp lever to the feel.





SERVICE PARTS LIST

BULLETIN NO.
54-06-2395

SPECIFY CATALOG NO. AND SERIAL NO. WHEN ORDERING PARTS		REVISED BULLETIN	DATE
M18™ ROVER™ MOUNTING FLOOD LIGHT			Jun. 2017
CATALOG NO.	2365-20	STARTING SERIAL NO.	J43A
WIRING INSTRUCTION			

EXAMPLE:

00	0
----	---

 Component Parts (Small #)
 Are Included When Ordering
 The Assembly (Large #).

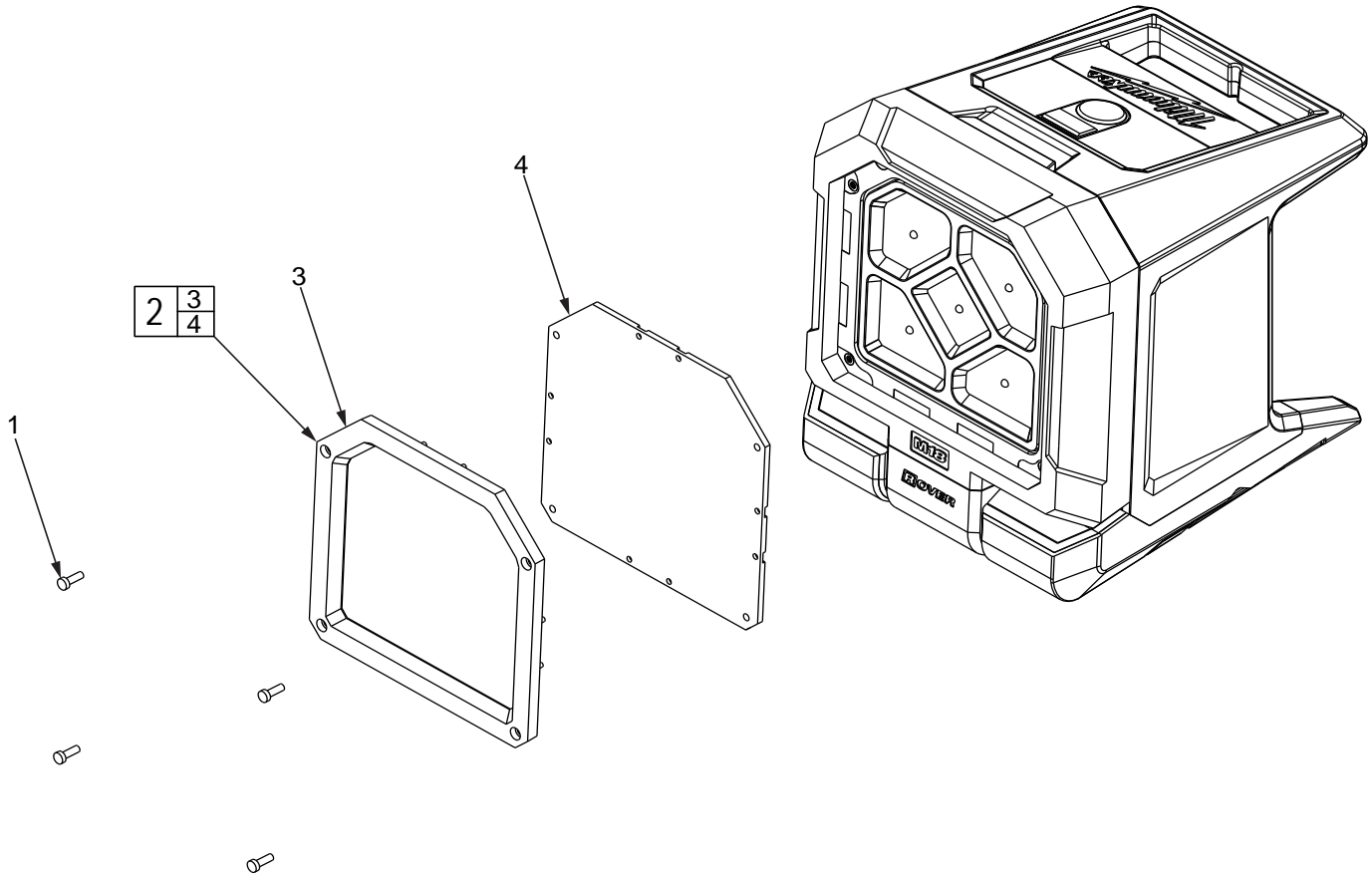

FIG.	PART NO.	DESCRIPTION OF PART	NO. REQ.
1	05-88-0013	M2.5 x 8 Pan Hd. Machine Screw	(4)
2	44-06-0011	Lens Assembly	(1)
3	-----	Lens Cover	(1)
4	-----	Lens	(1)
5	12-20-2335	Service Nameplate (Not Shown)	(1)

FIG. 5 NOTES
 5 A clean, dry surface is essential for proper performance for any adhesive system. The area intended for application of any adhesive label or nameplate must be prepared by cleaning with isopropyl alcohol. The solvent is to be applied with a clean, lint free applicator and the surface allowed to dry before applying the label or nameplate.



SERVICE PARTS LIST

BULLETIN NO.
54-06-2735

SPECIFY CATALOG NO. AND SERIAL NO. WHEN ORDERING PARTS		REVISED BULLETIN	DATE
CORDLESS 18 VOLT LED WORKLIGHT			Mar. 2012
CATALOG NO. 2735-20	STARTING SERIAL NO.	C12A	
		WIRING INSTRUCTION	

EXAMPLE:
Component Parts (Small #) Are Included When Ordering The Assembly (Large #).

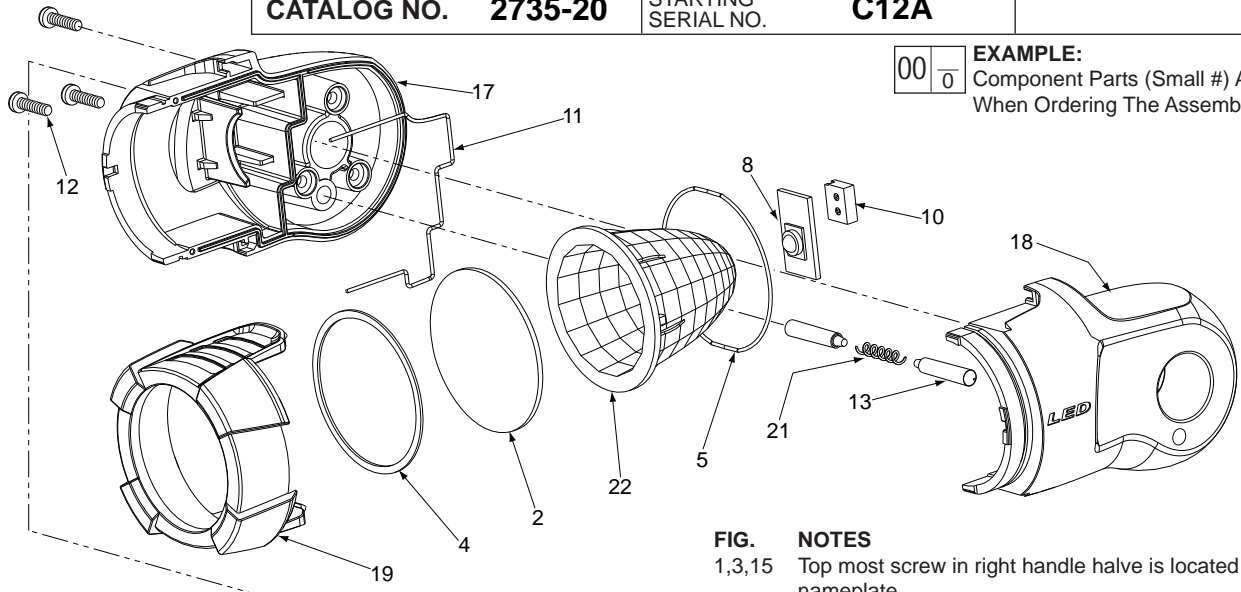
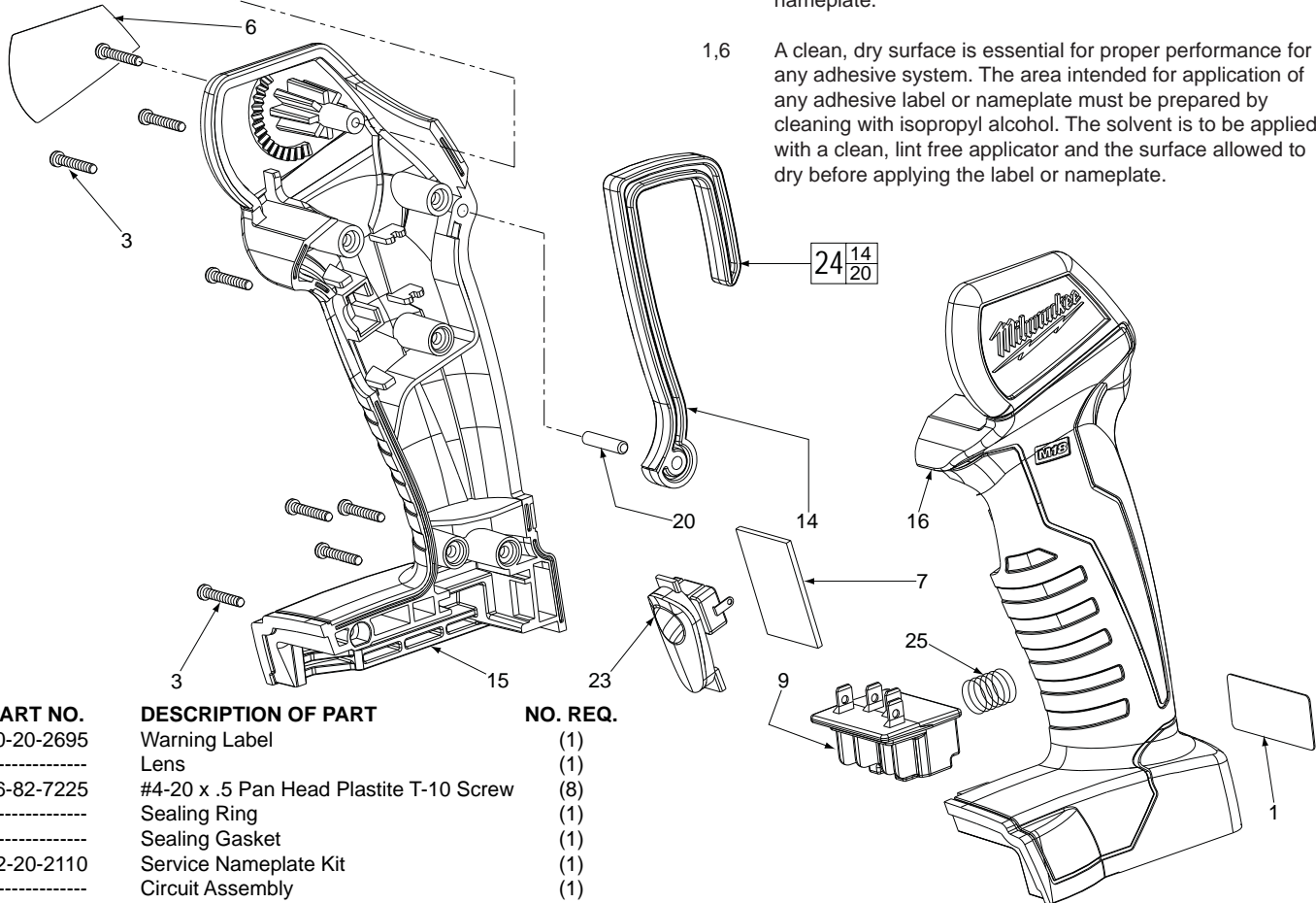

FIG. NOTES
1,3,15 Top most screw in right handle halve is located under the nameplate.



1,6 A clean, dry surface is essential for proper performance for any adhesive system. The area intended for application of any adhesive label or nameplate must be prepared by cleaning with isopropyl alcohol. The solvent is to be applied with a clean, lint free applicator and the surface allowed to dry before applying the label or nameplate.

FIG.	PART NO.	DESCRIPTION OF PART	NO. REQ.
1	10-20-2695	Warning Label	(1)
2	-----	Lens	(1)
3	06-82-7225	#4-20 x .5 Pan Head Plastite T-10 Screw	(8)
4	-----	Sealing Ring	(1)
5	-----	Sealing Gasket	(1)
6	12-20-2110	Service Nameplate Kit	(1)
7	-----	Circuit Assembly	(1)
8	-----	LED	(1)
9	-----	18 V Connector Block	(1)
10	-----	Sealing Washer	(1)
11	-----	Gasket	(1)
12	-----	M3 Screw	(3)
13	-----	Detent Pin	(2)
14	-----	Hook	(1)
15	-----	Right Handle Halve	(1)
16	-----	Left Handle Halve	(1)
17	-----	Right Housing	(1)
18	-----	Left Housing	(1)
19	-----	Bezel	(1)

FIG.	PART NO.	DESCRIPTION OF PART	NO. REQ.
20	-----	Pivot Pin	(1)
21	-----	Compression Spring	(1)
22	-----	Reflector	(1)
23	-----	Push Button Switch	(1)
24	43-74-0500	Hook and Pivot Pin Assembly	(1)
25	40-50-1090	Compression Spring	(1)



SERVICE PARTS LIST

BULLETIN NO.
54-06-2736

SPECIFY CATALOG NO. AND SERIAL NO. WHEN ORDERING PARTS			REVISED BULLETIN	DATE
CORDLESS 18 VOLT LED WORKLIGHT			54-06-2735	Aug. 2013
CATALOG NO.	2735-20	STARTING SERIAL NO.	WIRING INSTRUCTION	
		C12B		

EXAMPLE:
Component Parts (Small #) Are Included
When Ordering The Assembly (Large #).

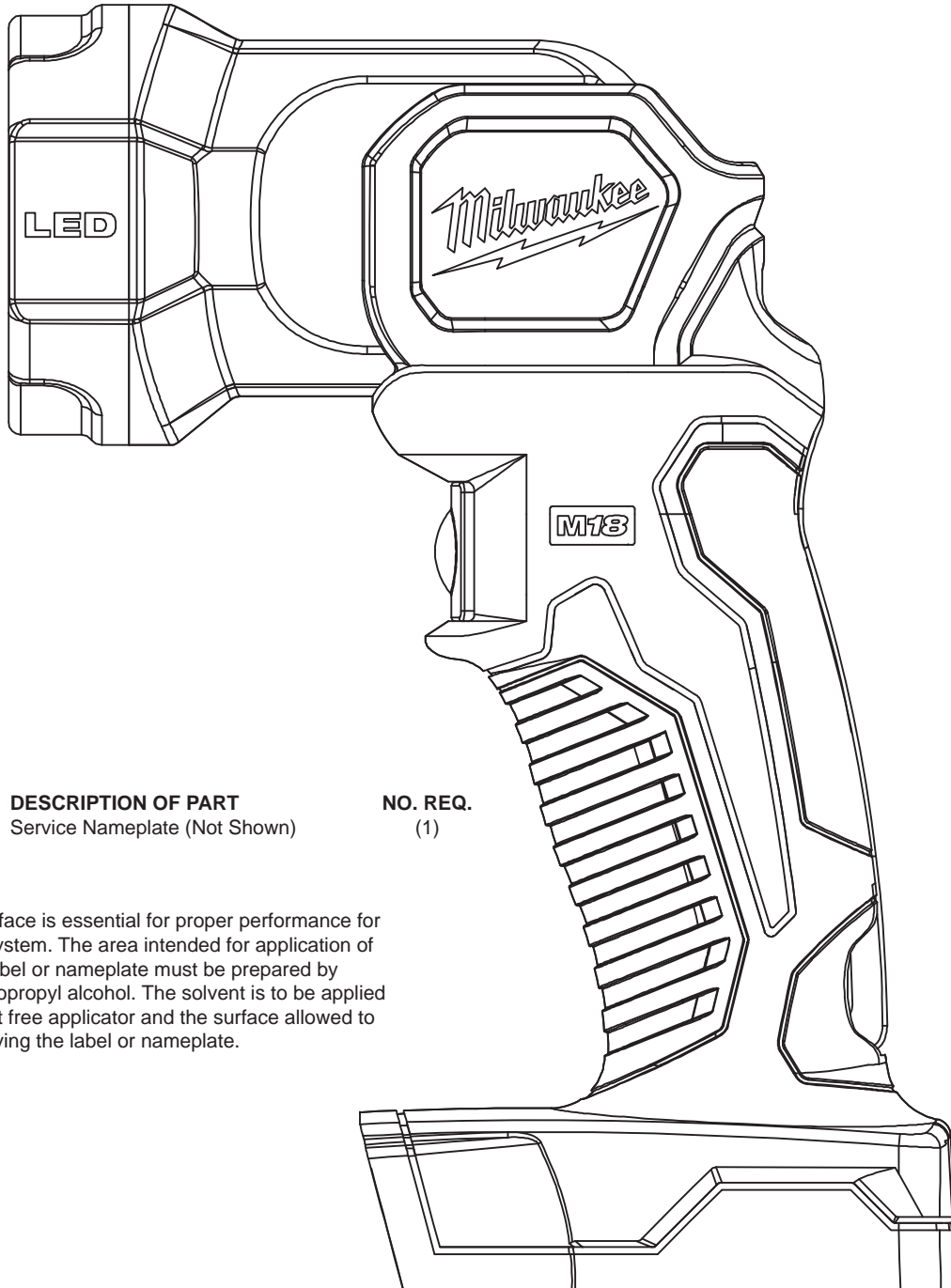

FIG.	PART NO.	DESCRIPTION OF PART	NO. REQ.
1	12-20-2111	Service Nameplate (Not Shown)	(1)

FIG. NOTES
1 A clean, dry surface is essential for proper performance for any adhesive system. The area intended for application of any adhesive label or nameplate must be prepared by cleaning with isopropyl alcohol. The solvent is to be applied with a clean, lint free applicator and the surface allowed to dry before applying the label or nameplate.