



SERVICE PARTS LIST

BULLETIN NO.
54-06-2380

| SPECIFY CATALOG NO. AND SERIAL NO. WHEN ORDERING PARTS | | | | REVISED BULLETIN | DATE |
|--|----------------|----------------------------|-------------|--------------------|-----------|
| M12™ SPOTLIGHT | | | | | July 2015 |
| CATALOG NO. | 2353-20 | STARTING SERIAL NO. | H01A | WIRING INSTRUCTION | |

EXAMPLE:

| | |
|----|---|
| 00 | 0 |
|----|---|

 Component Parts (Small #) Are Included When Ordering The Assembly (Large #).

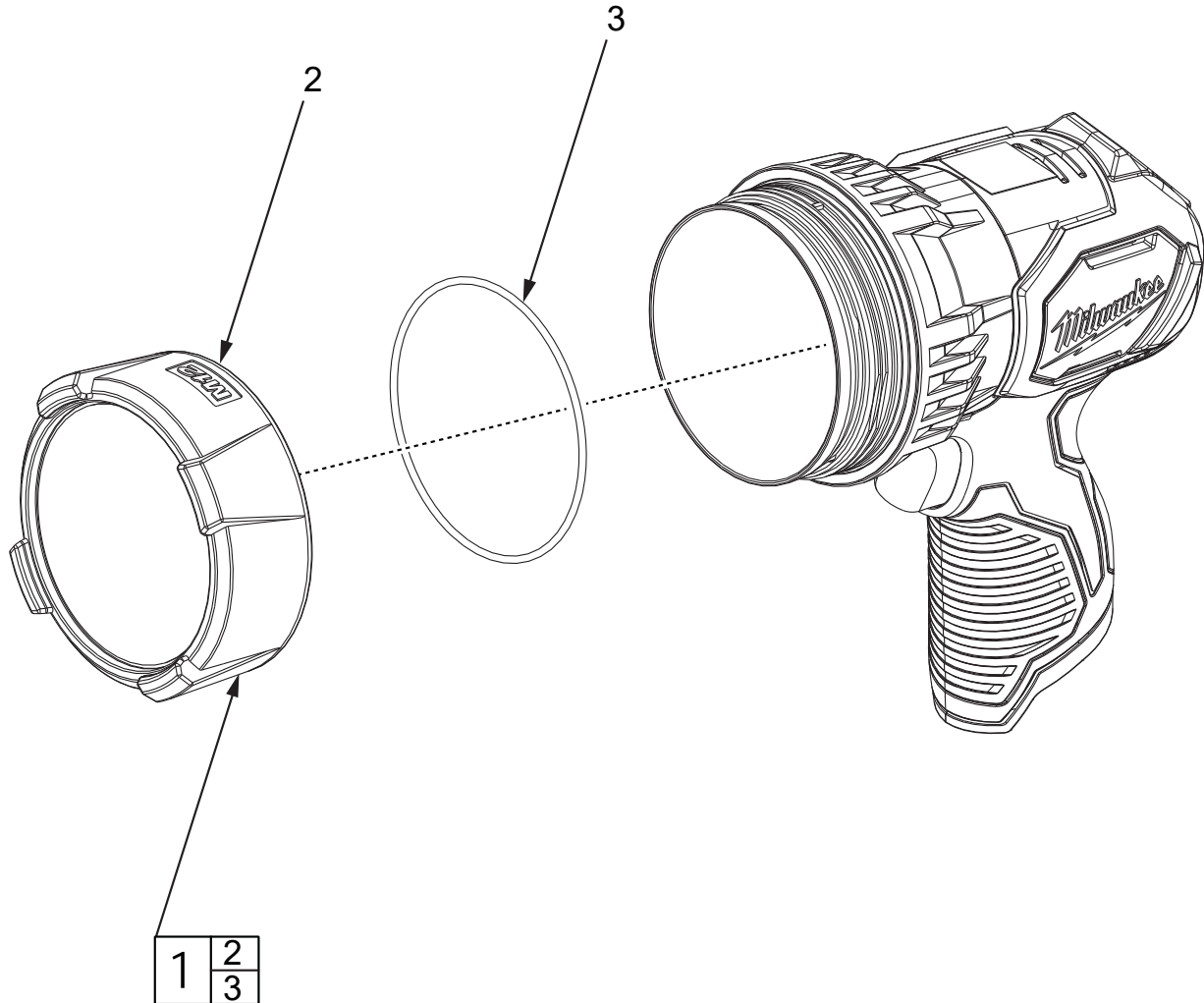

| FIG. | PART NO. | DESCRIPTION OF PART | NO. REQ. |
|------|------------|-------------------------------|----------|
| 1 | 14-38-2353 | Lens Assembly | (1) |
| 2 | ----- | Lens w/ Overmold | (1) |
| 3 | ----- | O-Ring | (1) |
| 4 | 12-20-2353 | Service Nameplate (not shown) | (1) |
| 5 | 45-56-0400 | Lanyard (Strap) (not shown) | (1) |
| 6 | 42-70-0058 | Housing Clip (not shown) | (1) |

FIG. 4 NOTES
 A clean, dry surface is essential for proper performance for any adhesive system. The area intended for application of any adhesive label or nameplate must be prepared by cleaning with isopropyl alcohol. The solvent is to be applied with a clean, lint free applicator and the surface allowed to dry before applying the label or nameplate.