



SERVICE PARTS LIST

BULLETIN NO.
54-06-2365

SPECIFY CATALOG NO. AND SERIAL NO. WHEN ORDERING PARTS		REVISED BULLETIN	DATE
CORDLESS M18™ LED STICK LIGHT			June 2014
CATALOG NO.	2352-20	STARTING SERIAL NO.	G21A
		WIRING INSTRUCTION	

00
0

EXAMPLE:
Component Parts (Small #) Are Included
When Ordering The Assembly (Large #).

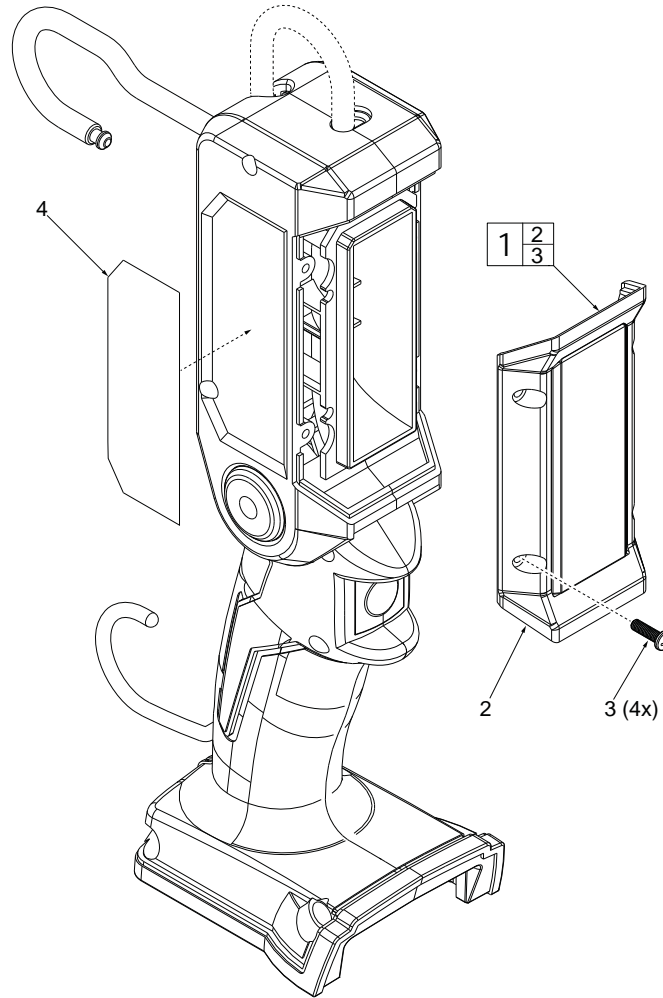

FIG.	PART NO.	DESCRIPTION OF PART	NO. REQ.
1	14-38-2352	Lens / Screw Assembly	(1)
2	-----	Lens Assembly	(1)
3	-----	M3 x 8mm Pan Hd. T-10 Screw	(4)
4	12-20-2352	Service Nameplate	(1)

FIG. NOTES

- 3 Care must be used when securing fasteners in tool. To prevent stripping do not over tighten. It is not recommended to use power tools, hand tighten only. Torque screws #4 to 5-7 in/lbs (6-8 kg/cm). Torque screws #10 to 3-4 in/lbs (3.5-4.5 kg/cm).
- 4 A clean, dry surface is essential for proper performance for any adhesive system. The area intended for application of any adhesive label or nameplate must be prepared by cleaning with isopropyl alcohol. The solvent is to be applied with a clean, lint free applicator and the surface allowed to dry before applying the label or nameplate.