

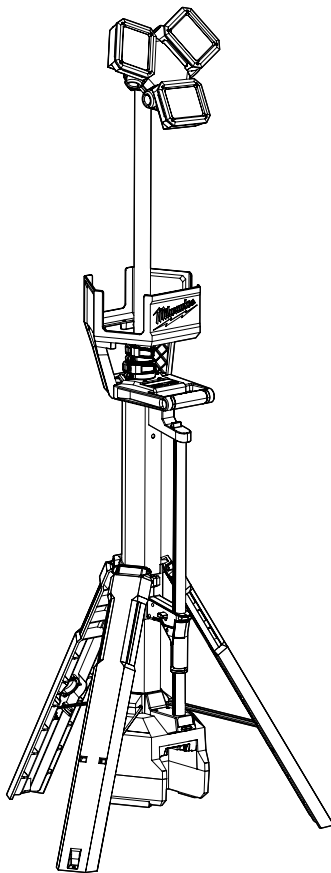

# OPERATOR'S MANUAL



Cat. No. / No de cat.  
2136-20

## M18™ **ROCKET™** LED TOWER LIGHT/CHARGER



**WARNING** To reduce the risk of injury, user must read and understand operator's manual.

# IMPORTANT SAFETY INSTRUCTIONS

**WARNING** Read all safety warnings and all instructions. Failure to follow the warnings and instructions may result in electric shock, fire and/or serious injury. **Save all warnings and instructions for future reference.**

## WORK AREA SAFETY

- **To reduce the risk of injury, close supervision is necessary** when an appliance is used near children.
- **Store idle light out of reach of children.** Warm lights can become hazardous in the hands of children.

## ELECTRICAL SAFETY

- **Power cord plugs must match the outlet. Never modify the plug in any way. Do not use any adapter plugs with earthed (grounded) power tools.** Unmodified plugs and matching outlets will reduce risk of electric shock.
- **Avoid body contact with earthed or grounded surfaces, such as pipes, radiators, ranges and refrigerators.** There is an increased risk of electric shock if your body is earthed or grounded.
- **To reduce the risk of electric shock, do not put light in water or other liquid.** Do not place or store appliance where it can fall or be pulled into a tub or sink.
- **Do not abuse the cord. Never use the cord for carrying, pulling or unplugging the power tool. Keep cord away from heat, oil, sharp edges or moving parts.**
- **Arrange cords carefully to avoid hazardous environments.** Tripping or snagging on cords can cause injury and product damage. Do not allow cords to run through puddles or across wet ground.
- **Do not unplug by pulling on the cord.** To unplug, grasp the plug, not the cord.
- **Unplug the cord from outlet when not in use and before servicing or cleaning.**
- **Always use a suitable extension cord to reduce the risk of electric shock.**
- **If operating a light in a damp location is unavoidable, use a ground fault circuit interrupter (GFCI) protected supply.** Use of an GFCI reduces the risk of electric shock.

## PERSONAL SAFETY

- **Do not overreach. Keep proper footing and balance at all times.** This enables better control of the light in unexpected situations.
- **Do not use on a ladder or unstable support.** Stable footing on a solid surface enables better control of the light in unexpected situations.
- **Prevent unintentional starting. Ensure the switch is in the off-position before connecting to power source and/or battery pack, picking up or carrying the tool.** Carrying power tools with your finger on the switch or energizing power tools that have the switch on invites accidents.

• **Disconnect the plug from the power source and/ or remove the battery pack, if detachable, from the power tool before making any adjustments, changing accessories, or storing power tools.** Such preventive safety measures reduce the risk of starting the power tool accidentally.

## BATTERY TOOL USE AND CARE

- **Recharge only with the charger specified by the manufacturer.** A charger that is suitable for one type of battery pack may create a risk of fire when used with another battery pack.
- **Use light only with specifically designated battery packs.** Use of any other battery packs may create a risk of injury and fire.
- **Do not short circuit.** A short-circuited battery pack may cause fire, personal injury, and product damage. A battery pack will short circuit if a metal object makes a connection between the positive and negative contacts on the battery pack. Do not place a battery pack near anything that may cause a short circuit, such as coins, keys or nails in your pocket.
- **Do not allow fluids to flow into battery pack.** Corrosive or conductive fluids, such as seawater, certain industrial chemicals, and bleach or bleach containing products, etc., can cause a short circuit.
- **Under abusive conditions, liquid may be ejected from the battery; avoid contact. If contact accidentally occurs, flush with water. If liquid contacts eyes, additionally seek medical help.** Liquid ejected from the battery may cause irritation or burns.
- **Do not use a battery pack or tool that is damaged or modified.** Damaged or modified batteries may exhibit unpredictable behavior resulting in fire, explosion or risk of injury.
- **Do not expose a battery pack or tool to fire or excessive temperature.** Exposure to fire or temperature above 265°F (130°C) may cause explosion.
- **Follow all charging instructions and do not charge the battery pack or tool outside the temperature range specified in the instructions.** Charging improperly or at temperatures outside the specified range may damage the battery and increase the risk of fire.

## CHARGER USE AND CARE

- **CAUTION** To reduce the risk of injury, charge only their MILWAUKEE Lithium-Ion packs only in their MILWAUKEE Lithium-Ion charger. Other types of batteries may burst causing personal injury and damage. Do not wire a battery pack to a power supply plug or car cigarette lighter. Batteries will be permanently disabled or damaged.
- **Charge only MILWAUKEE M18™ Lithium-Ion packs.** Other types of batteries may burst causing personal injury or damage.
- **Avoid dangerous environments.** Do not charge battery pack in rain, snow, damp or wet locations. Do not use battery pack or charger in the presence of explosive atmospheres (gaseous fumes, dust or flammable materials) because sparks may be generated when inserting or removing battery pack, possibly causing fire.

# FUNCTIONAL DESCRIPTION

- **Charge in a well ventilated area.** Do not block charger vents. Keep them clear to allow proper ventilation. Do not allow smoking or open flames near a charging battery pack. Vented gases may explode.
- **Maintain charger cord.** When unplugging charger, pull plug rather than cord to reduce the risk of damage to the electrical plug and cord. Never carry charger by its cord. Keep cord from heat, oil and sharp edges. Make sure cord will not be stepped on, tripped over or subjected to damage or stress. Do not use charger with damaged cord or plug. Have a damaged charger replaced immediately.
- **Use only recommended attachments.** Use of an attachment not recommended or sold by the battery charger or battery pack manufacturer may result in a risk of fire, electric shock or personal injury.
- **Unplug charger** when not in use. Remove battery packs from unplugged chargers.
- **To reduce the risk of electric shock,** always unplug charger before cleaning or maintenance. Do not allow water to flow into AC/DC plug. Use a Ground Fault Circuit Interrupter (GFCI) to reduce shock hazards.
- **Store your battery and charger** in a cool, dry place. Do not store battery pack where temperatures may exceed 120°F (50°C) such as in direct sunlight, a vehicle or metal building during the summer.

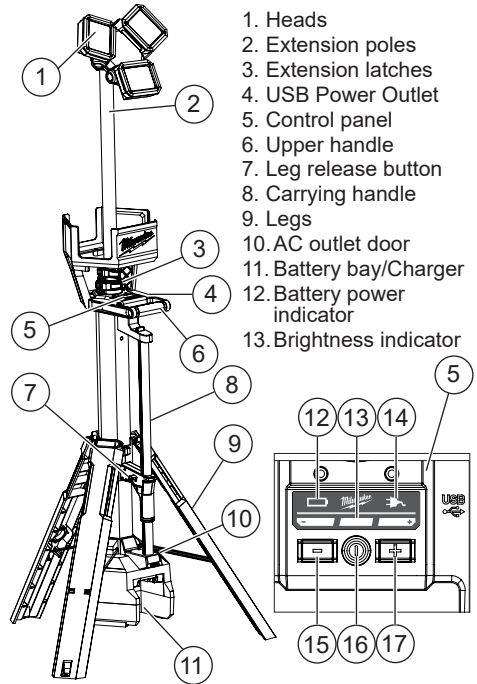

1. Heads
2. Extension poles
3. Extension latches
4. USB Power Outlet
5. Control panel
6. Upper handle
7. Leg release button
8. Carrying handle
9. Legs
10. AC outlet door
11. Battery bay/Charger
12. Battery power indicator
13. Brightness indicator

14. AC power indicator
15. Decrease brightness button
16. Power button
17. Increase brightness button

## SERVICE

- **Have your light serviced by a qualified repair person using only identical replacement parts.** This will ensure that the safety of the light is maintained.
- **Never service damaged battery packs.** Service of battery packs should only be performed by the manufacturer or authorized service providers.

## SPECIFIC SAFETY RULES

- **Warning - The lens may get hot during use.** To reduce the risk of burns, do not touch hot lens.
- **Suitable for rain and wet locations. Store indoors.**
- **Always use common sense and be cautious when using tools.** It is not possible to anticipate every situation that could result in a dangerous outcome. Do not use this tool if you do not understand these operating instructions or you feel the work is beyond your capability; contact Milwaukee Tool or a trained professional for additional information or training.
- **Maintain labels and nameplates.** These carry important information. If unreadable or missing, contact a MILWAUKEE service facility for a free replacement.

**READ AND SAVE ALL INSTRUCTIONS FOR FUTURE USE**

## SPECIFICATIONS

<b>Cat. No.</b> .....	<b>2136-20</b>
DC Input Volts.....	18
AC Input Volts.....	120
AC Input Amps.....	1.3
DC Output Volts.....	18
DC Output Amps.....	3.1
USB Output Volts.....	5.3
USB Output Amps.....	2.1
Operating Temperature	
Battery and Charger .....	32°F to 150°F (0°C to 65°C)
Battery and Tool.....	-4°F to 140°F (-20°C to 60°C)
<b>M18™ Li-Ion Battery Packs</b> .....	18 V DC

# SYMBOLOLOGY

-  Volts
-  Direct Current
-  Alternating Current
-  Amps
-  Double Insulated
-  UL Listing for Canada and U.S.
-  Do not stare at the operating light source
-  Always extend legs before raising the poles
-  Keep hands clear of housing when collapsing the extension poles
-  Read operator's manual
-  Universal Serial Bus (USB)
-  USB Power Button

•Protect your extension cords from sharp objects, excessive heat and damp or wet areas.

Recommended Minimum Wire Gauge For Extension Cords*					
Nameplate Amps	Extension Cord Length				
	25'	50'	75'	100'	150'
0 - 2.0	18	18	18	18	16
2.1 - 3.4	18	18	18	16	14
3.5 - 5.0	18	18	16	14	12
5.1 - 7.0	18	16	14	12	12
7.1 - 12.0	16	14	12	10	--
12.1 - 16.0	14	12	10	--	--
16.1 - 20.0	12	10	--	--	--

\* Based on limiting the line voltage drop to five volts at 150% of the rated amperes.

# GROUNDING

**WARNING** Improperly connecting the grounding wire can result in the risk of electric shock. Check with a qualified electrician if you are in doubt as to whether the outlet is properly grounded. Do not modify the plug provided with the tool. Never remove the grounding prong from the plug. Do not use the tool if the cord or plug is damaged. If damaged, have it repaired by a MILWAUKEE service facility before use. If the plug will not fit the outlet, have a proper outlet installed by a qualified electrician.

## Grounded Tools: Tools with Three Prong Plugs

Tools marked "Grounding Required" have a three wire cord and three prong grounding plug. The plug must be connected to a properly grounded outlet (See Figure A). If the tool should electrically malfunction or break down, grounding provides a low resistance path to carry electricity away from the user, reducing the risk of electric shock.

The grounding prong in the plug is connected through the green wire inside the cord to the grounding system in the tool. The green wire in the cord must be the only wire connected to the tool's grounding system and must never be attached to an electrically "live" terminal.

Your tool must be plugged into an appropriate outlet, properly installed and grounded in accordance with all codes and ordinances. The plug and outlet should look like those in Figure A.

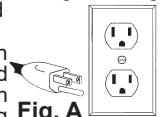

Fig. A

## Double Insulated Tools: Tools with Two Prong Plugs

Tools marked "Double Insulated" do not require grounding. They have a special double insulation system which satisfies OSHA requirements and complies with the applicable standards of Underwriters Laboratories, Inc., the Canadian Standard Association and the National Electrical Code. Double Insulated tools may be used in either of the 120 volt outlets shown in Figures B and C.

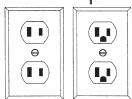

Fig. B Fig. C

# EXTENSION CORDS

Grounded tools require a three wire extension cord. Double insulated tools can use either a two or three wire extension cord. As the distance from the supply outlet increases, you must use a heavier gauge extension cord. Using extension cords with inadequately sized wire causes a serious drop in voltage, resulting in loss of power and possible tool damage. Refer to the table shown to determine the required minimum wire size.

The smaller the gauge number of the wire, the greater the capacity of the cord. For example, a 14 gauge cord can carry a higher current than a 16 gauge cord. When using more than one extension cord to make up the total length, be sure each cord contains at least the minimum wire size required. If you are using one extension cord for more than one tool, add the nameplate amperes and use the sum to determine the required minimum wire size.

## Guidelines for Using Extension Cords

- If you are using an extension cord outdoors, be sure it is marked with the suffix "W" to indicate that it is acceptable for outdoor use.
- Be sure your extension cord is properly wired and in good electrical condition. Always replace a damaged extension cord or have it repaired by a qualified person before using it.

# ASSEMBLY

**WARNING** Recharge only with the charger specified for the battery. For specific charging instructions, read the operator's manual supplied with your charger and battery.

## Inserting/Removing Battery Pack

Insert the battery pack by sliding battery pack into the battery bay. Insert the battery pack until the battery latches lock.

To remove the battery pack, press in both battery latches and slide the battery pack out of the battery bay.

## Inserting/Removing Extension Cord

When not using the AC option, make sure the AC doors are closed completely.

To operate the light on AC power, extend and lock legs. Open the door and plug a suitable extension cord into the light. To disconnect the extension cord, press the Power button to turn off the light, then remove the cord from the outlet.

**NOTE:** When an extension cord is plugged into the light, the light will automatically run on AC power.

**CAUTION** To reduce the risk of injury, do not stare at the operating light source.

**WARNING** To reduce the risk of injury, always fully extend and lock legs into position before raising the poles. Light may tip and cause injury.

To reduce the risk of injury, keep hands clear of the housing area when collapsing the extension poles. Head may descend rapidly, pinching hands and fingers.

## Extending/Collapsing the Legs

Always extend and lock legs before raising the poles.

1. Stand light upright.
2. Press the Leg Release Button and slide the legs down using the Carrying Handle.
3. Lift up on the Upper Handle while sliding down the Carrying Handle.
4. Lift until the Battery Bay lifts off the floor and the legs lock into place.
5. To collapse, hold with upper handle, press the Leg Release Button and slide in the legs using the Carrying Handle. Keep hands clear of the legs as they collapse.

## Extending/Collapsing the Extension Poles

Extend or collapse the two poles to set the light at the desired height.

1. Extend and lock the legs.
2. Open the top extension latch and raise the head out of the housing. Extend the pole to the desired height.
3. Fully close top extension latch.
4. If more height is needed, fully extend first pole and close latch before opening bottom latch.
5. Continue to raise the head to the desired height.
6. Fully close bottom extension latch.
7. Rotate the heads to the desired angle. The three heads can be adjusted individually.

**NOTE:** Before collapsing the poles, the heads must be returned to their upright angle.

## USB Power Outlet

This outlet can be used to charge a cell phone, power an MP3 player or any other device that uses less than 2.1 A of DC electrical current. To turn the USB on or off, press the USB Power button. The USB port will automatically shut off after two hours of inactivity.

**NOTE:** Any device that uses more than 2.1A of DC electrical current will trip a self-resetting overload and disable the output.

# LIGHT OPERATION

**CAUTION** To reduce the risk of injury, do not stare at the operating light source.

## Using the Light

1. Insert battery pack or plug into AC power.
2. Press the Power button to turn on the light.  
**NOTE:** When the light is running on battery, the Battery Power Indicator will light. When the light is running on AC power, the AC Power Indicator will light.
3. Press the Increase + and Decrease - buttons to cycle through High, Medium, and Low brightness.  
**NOTE:** The light will default to the selected brightness the next time it is turned on.
4. Press the Power button to turn the light off. Always turn off power before unplugging the light.

# BATTERY OPERATION

## Fuel Gauge

Use the Fuel Gauge to determine the battery pack's remaining run time. Press the Fuel Gauge button to display the lights. The Fuel Gauge will light up for 2-3 seconds. When less than 10% of charge is left, 1 light on the fuel gauge will flash slowly.

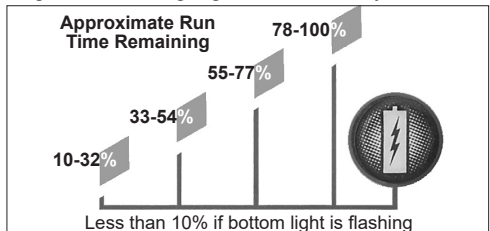

**NOTE:** If the Fuel Gauge doesn't appear to be working, place the battery pack on the charger and charge as needed.

Compared to NiCd battery pack types, MILWAUKEE Lithium-Ion battery packs deliver fade-free power for their entire run time. The tool will not experience a slow, gradual loss of power as you work. To signal the end of discharge, 1 light on the fuel gauge will flash quickly for 2-3 seconds and the tool will not run. Charge the battery pack.

**NOTE:** Immediately after using the battery pack, the Fuel Gauge may display a lower charge than it will if checked a few minutes later. The battery cells "recover" some of their charge after resting.

## Battery Pack Protection

To protect itself from damage and extend its life, the battery pack's intelligent circuit monitors current draw and temperature. In extremely high torque, binding, stalling, and short circuit situations, the battery pack will turn OFF the tool if the current draw becomes too high. All the fuel gauge lights will flash. Release the trigger and restart.

Under extreme circumstances, the internal temperature of the battery could become too high. If this happens, the fuel gauge lights will flash in an alternating pattern and the tool will not run. Allow the battery to cool down.

Fuel Gauge Lights	Diagnosis	Solution
Lights 1 - 4 Solid	Remaining run time	Continue working
1 Light, flashing slowly	Less than 10% run time left	Prepare to charge pack
1 Light, flashing quickly	End of discharge	Charge pack
Lights 1-4, flashing quickly	Current draw too high	Release trigger and restart, reduce pressure
Lights 1&3 / 2&4, flashing alternately	Battery temperature too high	Release trigger and allow battery to cool

### Cold Weather Operation

MILWAUKEE Lithium-Ion battery packs are designed to operate in temperatures below freezing. When the battery pack is too cold, it may need to warm up before normal use. Put the battery on a tool and use the tool in a light application. It may "buzz" for a short time until it warms up. When the buzzing stops, use the tool normally.

### Maintenance and Storage

Do not expose your battery pack or cordless tools to water or rain, or allow them to get wet. This could damage the tool and battery pack. Do not use oil or solvents to clean or lubricate your battery pack. The plastic casing will become brittle and crack, causing a risk of injury.

Store battery packs at room temperature away from moisture. Do not store in damp locations where corrosion of terminals may occur. As with other battery pack types, permanent capacity loss can result if the pack is stored for long periods of time at high temperatures (over 120° F). MILWAUKEE Lithium-Ion battery packs maintain their charge during storage longer than other battery pack types. After about a year of storage, charge the pack as normal.

### Transport

Personal transport of Li-Ion battery packs is allowed when done in accordance with these warnings and instructions. The proper classification, packaging, labeling, marking, and documentation requirements for shipping Li-Ion batteries is dependent upon whether the particular batteries are rated greater than or less than 100 Wh (Watt Hours can be found on the battery pack nameplate). Generally, Li-Ion batteries rated 100 Wh or less are "excepted" from certain Class 9 DG requirements. Always check compliance of Li-Ion battery consignments against the current regulations governing the chosen mode of transport. When in doubt, contact the carrier or other trained Dangerous Goods professional to confirm acceptability. Li-Ion packs are shipped under classification UN 3480 (battery only) or UN 3481 (batteries contained in or packed with equipment).

**⚠WARNING** To reduce the risk of injury or explosion, never burn or incinerate a battery pack even if it is damaged, dead or completely discharged. When burned, toxic fumes and materials are created.

### Disposing of MILWAUKEE Lithium-Ion Battery Packs

MILWAUKEE Lithium-Ion battery packs are more environmentally friendly than some other types of power tool battery packs (e.g., nickel-cadmium). Always dispose of your battery pack according to federal, state and local regulations. Contact a recycling agency in your area for recycling locations. Even discharged battery packs contain some energy. Before disposing, use electrical tape to cover the terminals to prevent the battery pack from shorting, which could cause a fire or explosion.

### RBRC Battery Recycling Seals

The RBRC™ Battery Recycling Seals (see "Sym-bology") on your tool battery packs indicate that MILWAUKEE has arranged for the recycling of that battery pack with the Rechargeable Battery Recycling Corporation (RBRC). At the end of your battery pack's useful life, return the battery pack to a MILWAUKEE Branch Office/Service Center or the participating retailer nearest you. For more information, visit the RBRC web site at [www.rbrc.org](http://www.rbrc.org).

## CHARGER OPERATION

**⚠WARNING** Charge only MILWAUKEE M18™ Lithium-Ion batteries in this MILWAUKEE Lithium-Ion charger. Other types of batteries may cause personal injury and damage.

### When to Charge the Battery Pack

To charge the battery pack, connect the light to AC power and insert a battery pack. The light will remain operational when the battery pack is charging. MILWAUKEE batteries do not develop a "memory" when charged after only a partial discharge. It is not necessary to run down the battery pack before placing it on the charger.

- Use the Fuel Gauge to determine when to charge your MILWAUKEE Lithium-Ion battery pack.
- You can "Top-Off" your battery pack's charge before starting a big job or long day of use.
- The only time it is necessary to charge the MILWAUKEE Lithium-Ion battery pack is when the battery pack has reached the end of its charge. To signal the end of charge, power to the tool will drop quickly, allowing you just enough power to finish making a cut, drilling a hole, or driving a fastener. Charge the battery pack as needed.

### How to Charge the Battery Pack

Plug the light into a 120V outlet. The battery packs will not charge if the Stand Light Charger is not plugged in. Align the battery pack with the bay and slide the battery pack into the charger as far as possible.

- When a battery pack is inserted into the charger, the LEDs will indicate the following:



Continuous red: Charging



Continuous green light: Charging is complete



Flashing red: Battery is too hot/cold

Charging will begin when battery reaches correct charging temperature



Flashing red/green: Damaged or faulty battery pack

- A fully discharged battery pack with an internal temperature in the normal range will charge in about 30 to 185 minutes, depending on the battery pack.
- Heavily cycled batteries may take longer to charge completely.
- The Fuel Gauge lights on the battery pack are displayed as the pack is being charged, indicating how fully charged the pack is. The fuel gauge will turn off when charging is complete.
- After charging is complete, the continuous green light will come on.
- The charger will keep the battery pack fully charged if it is left on the charger. The light indicator will flash green during this maintenance charging.

# ACCESSORIES



**WARNING**

Use only recommended accessories. Others may be hazardous.

- If the light indicator flashes red and green, check that the battery pack is fully seated into the bay. Remove the pack and reinsert. If the problem persists, contact a MILWAUKEE service facility.
- If the light indicator does not come on, check that the battery pack is fully seated into the bay. Remove the battery pack and reinsert. If the light indicator still does not come on, contact a MILWAUKEE service facility.

## Charging a Hot or Cold Battery Pack

The Red Flashing Indicator light on the charger indicates that the battery pack temperature is outside the charging range. Once the battery pack is within the acceptable range, normal charging will take place and the red light will be continuous. Hot or cold batteries may take longer to charge.

### Lithium-Ion Charging Status

Battery Pack Temperature	Red Charger Indicator Light	Charging Status
Too Hot	Fast Flashing	Not charging
Normal Range	Continuous	Normal charging
Too Cold	Fast Flashing	Not charging

# MAINTENANCE

**WARNING** To reduce the risk of injury, always unplug the charger and remove the battery pack from the charger before performing any maintenance. Never disassemble the tool, battery pack or charger. Contact a MILWAUKEE service facility for ALL repairs.

To reduce the risk of fire, personal injury, and product damage due to a short circuit, never immerse your tool, battery pack or charger in fluid or allow a fluid to flow inside them. Corrosive or conductive fluids, such as seawater, certain industrial chemicals, and bleach or bleach containing products, etc., can cause a short circuit.

## Maintaining Light

Keep your light, battery pack and charger in good repair by adopting a regular maintenance program. If the light does not work properly, return the light to a MILWAUKEE service facility for repairs.

## Tightening

If the head or extensions will not hold their position, the screws may need to be tightened. Tighten the bracket screws by holding the head. Tighten the extension latches by opening the latches and tightening the screw inside.

**WARNING** To reduce the risk of personal injury and damage, never immerse your tool, battery pack or charger in liquid or allow a liquid to flow inside them.

## Cleaning

Clean dust and debris from vents. Keep handles clean, dry and free of oil or grease. Use only mild soap and a damp cloth to clean, since certain cleaning agents and solvents are harmful to plastics and other insulated parts. Do not use sprays or solvents. Some of these include gasoline, turpentine, lacquer thinner, paint thinner, chlorinated cleaning solvents, ammonia and household detergents containing ammonia. Never use flammable or combustible solvents around tools.

Discover other hand lamps on our website.