



SERVICE PARTS LIST

BULLETIN NO.
54-06-2210

SPECIFY CATALOG NO. AND SERIAL NO. WHEN ORDERING PARTS				REVISED BULLETIN	DATE
HEADLAMP					Oct. 2018
CATALOG NO.	2103	STARTING SERIAL NO.	K56A	WIRING INSTRUCTION	

EXAMPLE:

00	0
----	---

 Component Parts (Small #)
 Are Included When Ordering
 The Assembly (Large #).

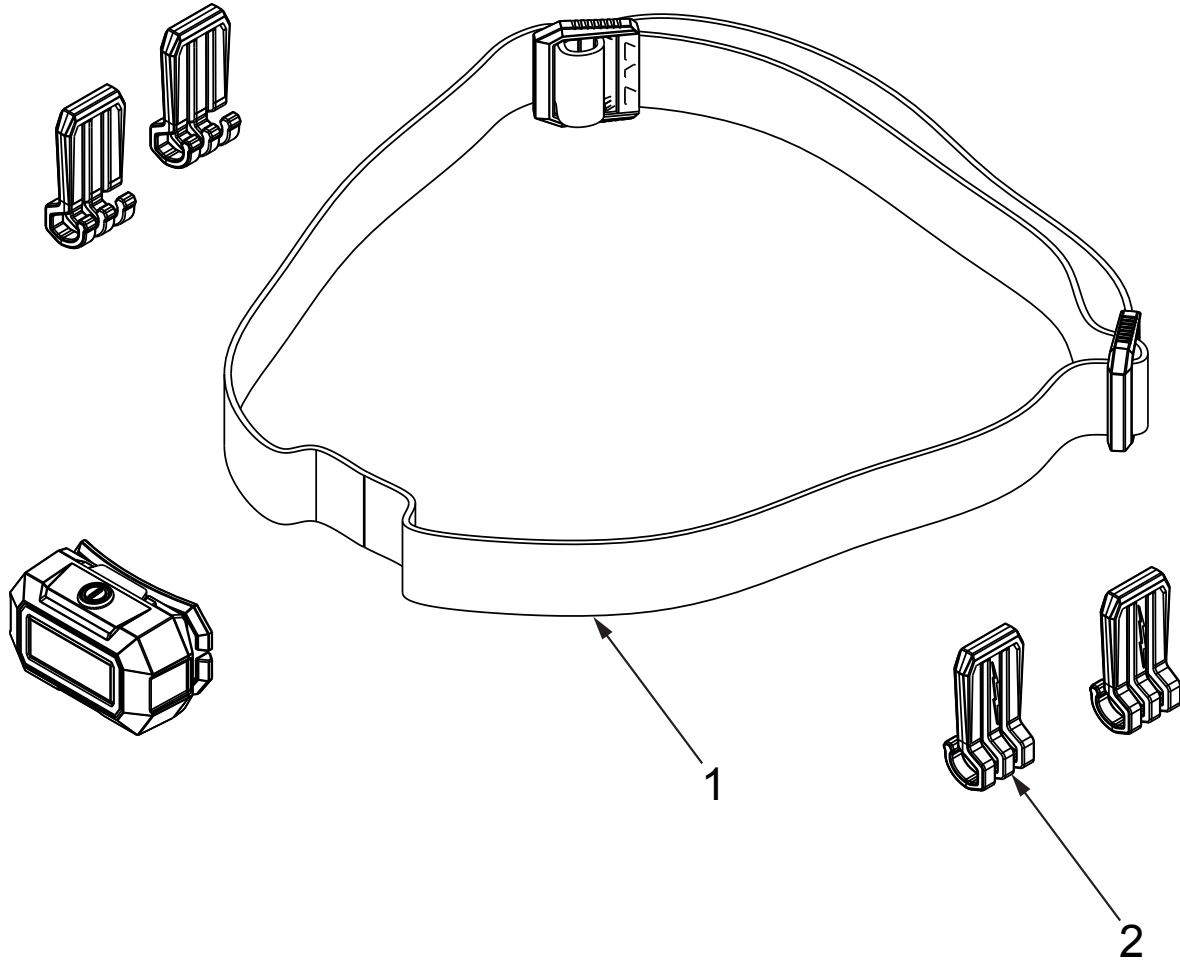

FIG.	PART NO.	DESCRIPTION OF PART	NO. REQ.
1	45-56-2103	Strap	(1)
2	42-70-2103	Hard Hat Clips (Set of 4)	(1)
3	12-20-2103	Service Nameplate (Not Shown)	(1)

FIG. NOTES

3 A clean, dry surface is essential for proper performance for any adhesive system. The area intended for application of any adhesive label or nameplate must be prepared by cleaning with isopropyl alcohol. The solvent is to be applied with a clean, lint free applicator and the surface allowed to dry before applying the label or nameplate.