

# WIRING INSTRUCTIONS

TITLE

**SUPER HAWG**

BULLETIN  
**58-01-0695**

DATE  
Feb. 2005

**SEE THE BACK OF THIS WIRING INSTRUCTION FOR WIRE ROUTING DETAILS.**

CORD JACKET IS TO EXTEND .25 MINIMUM PAST CORD CLAMP.

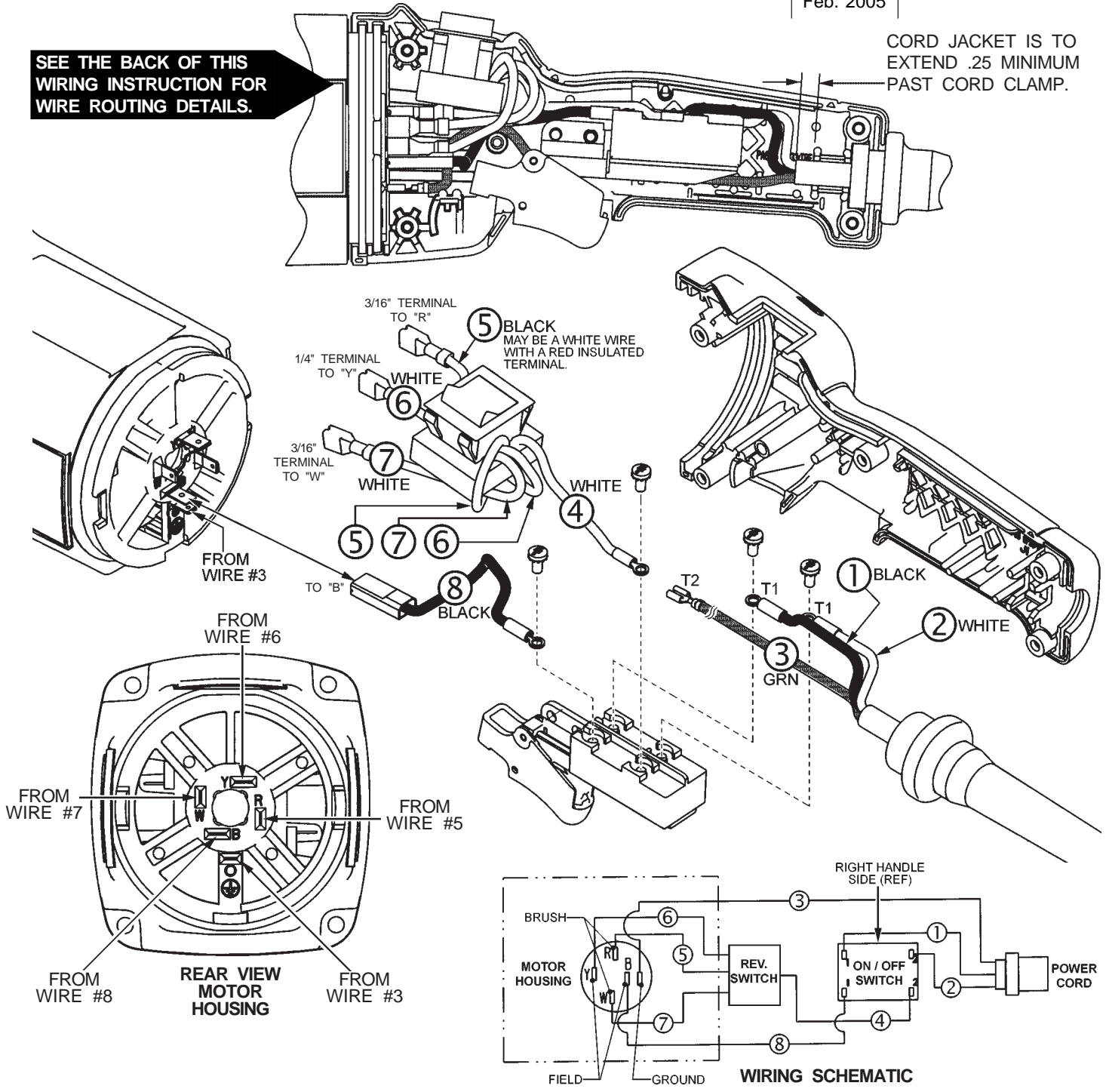

## WIRING SPECIFICATIONS

Wire No.	Wire Color	Origin or Part No.	Gauge	Length	Terminals, Connectors and End Wire Preparation
1	Black	22-64-1260	16	3.5	Component of the cord assembly. Strip .19 For T1.
2	White	22-64-1260	16	2.5	Component of the cord assembly. Strip .19 For T1.
3	Green	22-64-1260	16	7.5	Component of the cord assembly. Strip .19 For T2.
4	White	23-66-2360	--	--	Component of the reversing switch assembly.
5	BLACK or WHITE	23-66-2360	--	--	Component of the reversing switch assembly.
6	White	23-66-2360	--	--	Component of the reversing switch assembly.
7	White	23-66-2360	--	--	Component of the reversing switch assembly.
8	Black	23-94-2270	--	--	Leadwire assembly.

NOTE:  
All leads must be held to ± 1/8".  
All lead lengths are before stripping.

## TERMINAL DESCRIPTION

Code	Part No.	Qty.
T1	23-74-0870	2
T2	23-74-1095	1

**BULK LEAD WIRE - BULLETIN 58-01-0003**

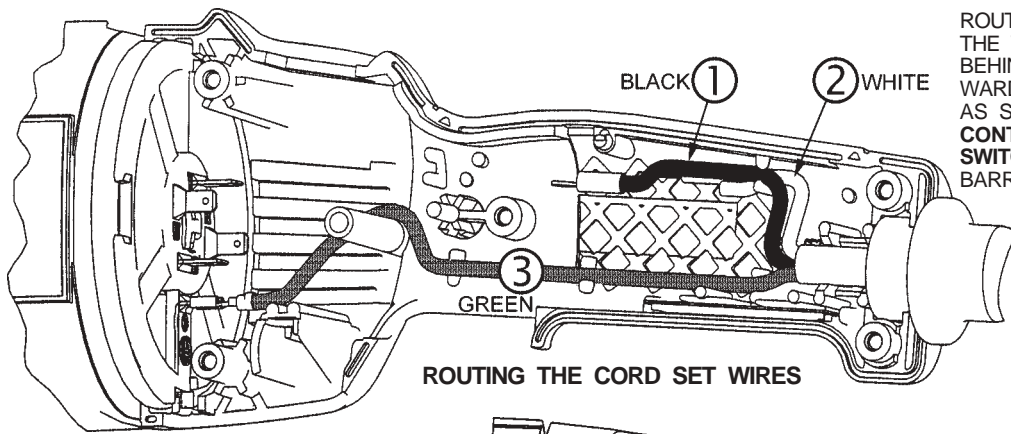

**ROUTING THE CORD SET WIRES**

ROUTE GREEN GROUND WIRE (3) THROUGH THE WIRE TRAPS IN THE RIGHT HANDLE, BEHIND THE ON/OFF SWITCH AND DOWNWARD AROUND THE WIRE GUIDE POSTS, AS SHOWN. **GREEN WIRE (3) MUST NOT CONTACT THE TRIGGER OF THE ON/OFF SWITCH.** ORIENT THE TERMINAL WITH THE BARRELS FACING UPWARD.

ROUTE THE WHITE CORD WIRE (2) TO THE ON/OFF SWITCH. PLACE THE WHITE CORD WIRE INTO THE BOTTOM OF THE WIRE TRAP, AS SHOWN.

ROUTE THE BLACK CORD WIRE (1) TO THE ON/OFF SWITCH. PLACE THE BLACK CORD WIRE OVER THE WHITE CORD WIRE IN THE WIRE TRAP, AS SHOWN.

ROUTE THE BLACK LEADWIRE ASSEMBLY (8) FROM THE MOTOR HOUSING TERMINAL "B" TO THE ON/OFF SWITCH. ROUTE THE LEADWIRE ASSEMBLY BETWEEN THE WIRE TRAP AND THE SWITCH BOSS AND AROUND THE WIRE GUIDE POST, AS SHOWN. (DO NOT PLACE WIRE IN TRAP).

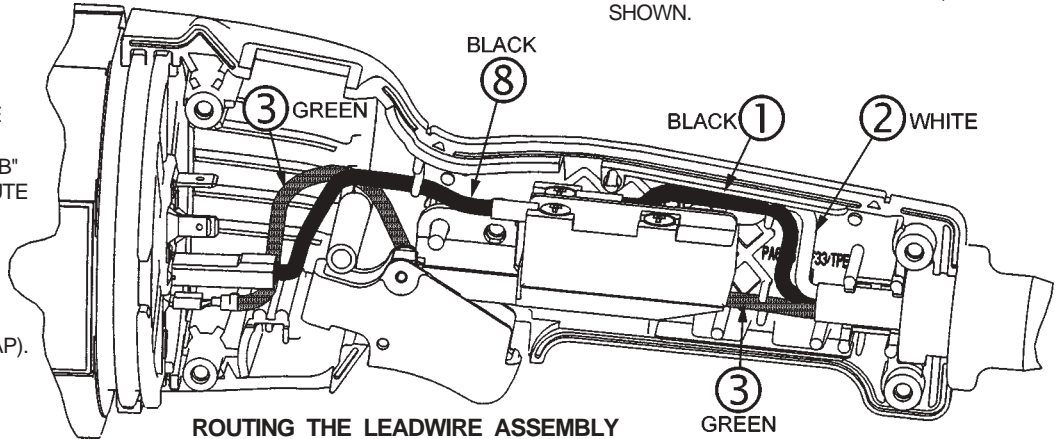

**ROUTING THE LEADWIRE ASSEMBLY**

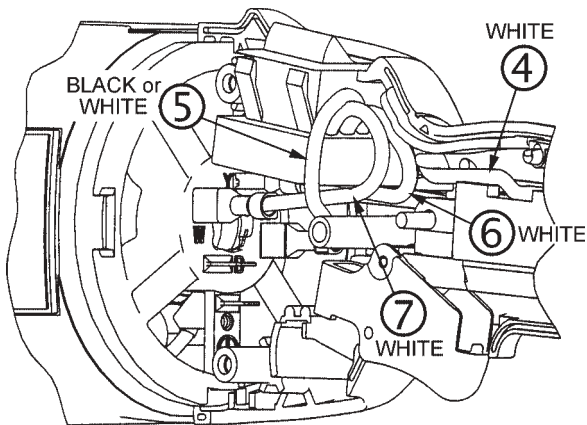

**ROUTING THE REVERSE SWITCH WIRES**

ROUTE THE BLACK WIRE (5), WITH THE .187 QUICK CONNECT RECEPTACLE (THIS WIRE MAY BE WHITE WITH A RED INSULATED TERMINAL) OVER WHITE WIRES (6 AND 7) AND IN FRONT OF THE WIRE GUIDE POST, AS SHOWN.

ROUTE THE WHITE WIRE (4), WITH THE RING TERMINAL, THROUGH THE WIRE TRAP TO THE ON/OFF SWITCH, AS SHOWN.

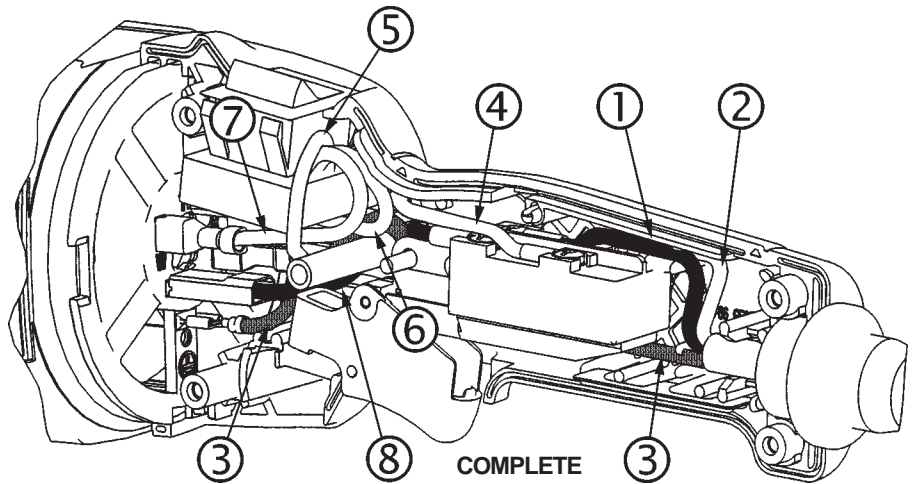

**COMPLETE WIRE ROUTING**

**FIELD NOTE:**

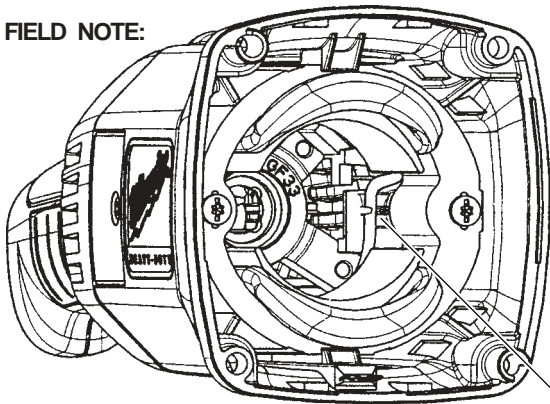

AFTER INSTALLING THE FIELD INTO THE MOTOR HOUSING, ENSURE THAT THE FIELD LEADWIRE IS ROUTED THROUGH THE WIRE TRAP AND IS HELD SECURELY. THE FIELD AND LEADWIRE MAY BE INSTALLED 180° FROM THE ORIENTATION SHOWN.

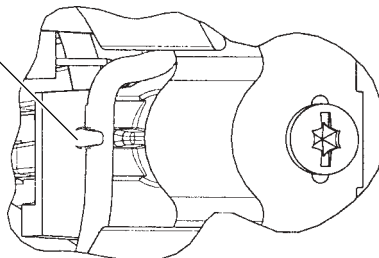

# WIRING INSTRUCTIONS

TITLE

**SUPER HAWG**

BULLETIN  
**58-01-0696**

DATE  
June 2014

**SEE THE BACK OF THIS WIRING INSTRUCTION FOR ROUTING DETAILS.**

CORD JACKET IS TO EXTEND .25 MINIMUM PAST CORD CLAMP.

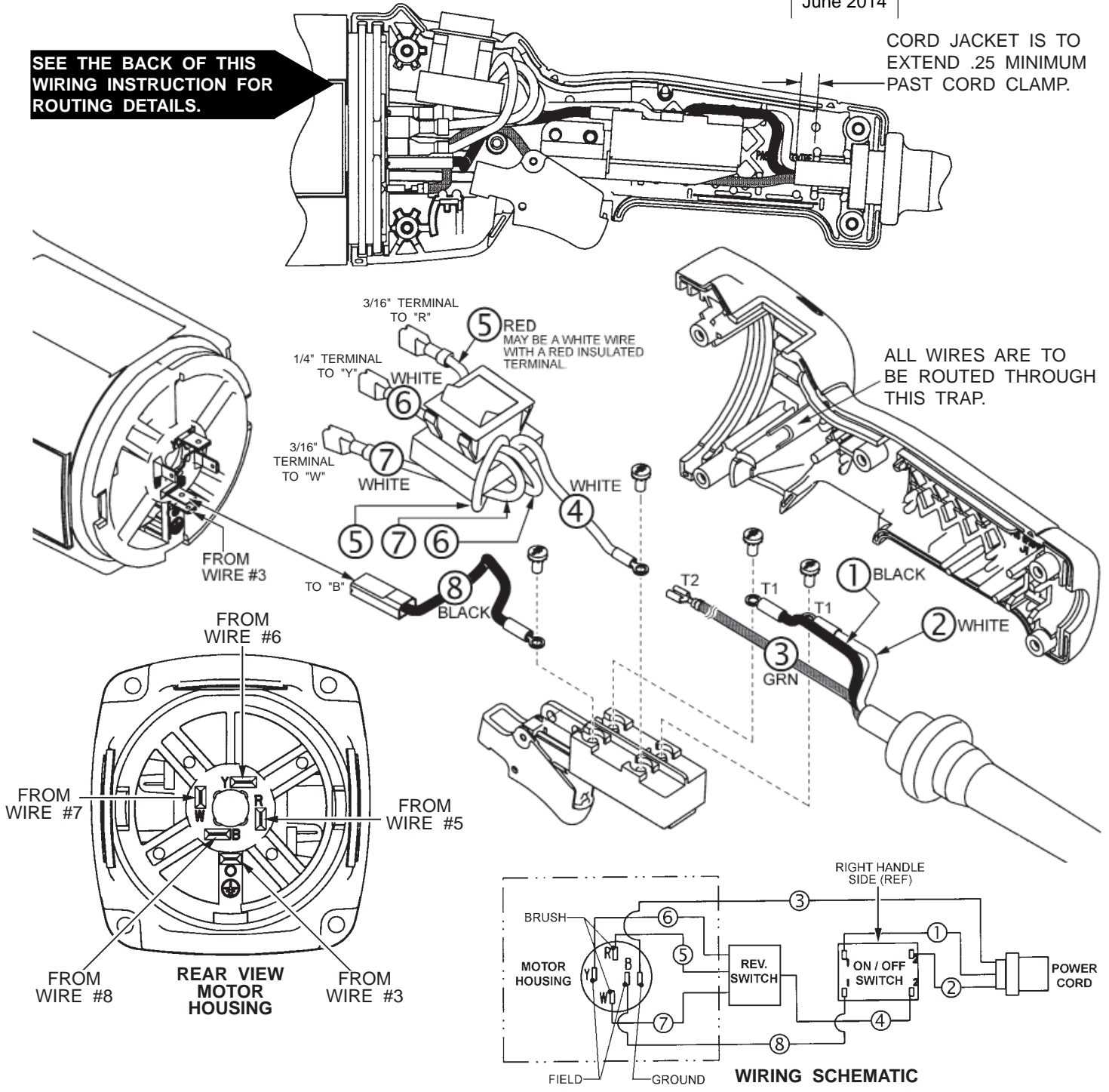

**WIRING SPECIFICATIONS**

Wire No.	Wire Color	Origin or Part No.	Gauge	Length	Terminals, Connectors and End Wire Preparation
1	Black	22-64-1260	16	3.5	Component of the cord assembly. Strip .19 For T1.
2	White	22-64-1260	16	2.5	Component of the cord assembly. Strip .19 For T1.
3	Green	22-64-1260	16	7.5	Component of the cord assembly. Strip .19 For T2.
4	White	23-66-2360	--	--	Component of the reversing switch assembly.
5	Red	23-66-2360	--	--	Component of the reversing switch assembly.
6	White	23-66-2360	--	--	Component of the reversing switch assembly.
7	White	23-66-2360	--	--	Component of the reversing switch assembly.
8	Red	23-94-2270	--	--	Leadwire assembly.

NOTE:  
All leads must be held to  $\pm 1/8"$ .  
All lead lengths are before stripping.

**TERMINAL DESCRIPTION**

Code	Part No.	Qty.
T1	23-74-0870	2
T2	23-74-1095	1

**BULK LEAD WIRE - BULLETIN 58-01-0003**

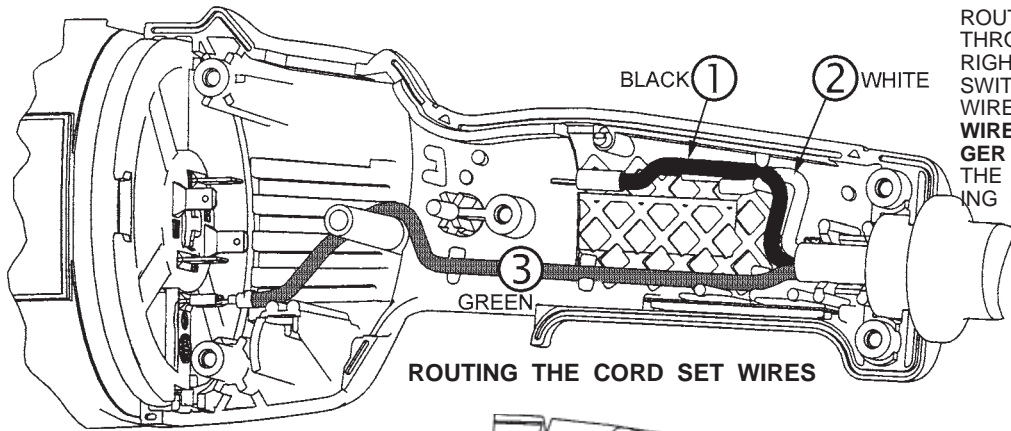

**ROUTING THE CORD SET WIRES**

ROUTE GREEN GROUND WIRE (3) THROUGH THE WIRE TRAPS IN THE RIGHT HANDLE, BEHIND THE ON/OFF SWITCH AND DOWNWARD AROUND THE WIRE GUIDE POSTS, AS SHOWN. **GREEN WIRE (3) MUST NOT CONTACT THE TRIGGER OF THE ON/OFF SWITCH.** ORIENT THE TERMINAL WITH THE BARRELS FACING UPWARD.

ROUTE THE WHITE CORD WIRE (2) TO THE ON/OFF SWITCH. PLACE THE WHITE CORD WIRE INTO THE BOTTOM OF THE WIRE TRAP, AS SHOWN.

ROUTE THE BLACK CORD WIRE (1) TO THE ON/OFF SWITCH. PLACE THE BLACK CORD WIRE OVER THE WHITE CORD WIRE IN THE WIRE TRAP, AS SHOWN.

ROUTE THE RED LEADWIRE ASSEMBLY (8) FROM THE MOTOR HOUSING TERMINAL "B" TO THE ON/OFF SWITCH. ROUTE THE LEADWIRE ASSEMBLY BETWEEN THE WIRE TRAP AND THE SWITCH BOSS AND AROUND THE WIRE GUIDE POST, AS SHOWN.

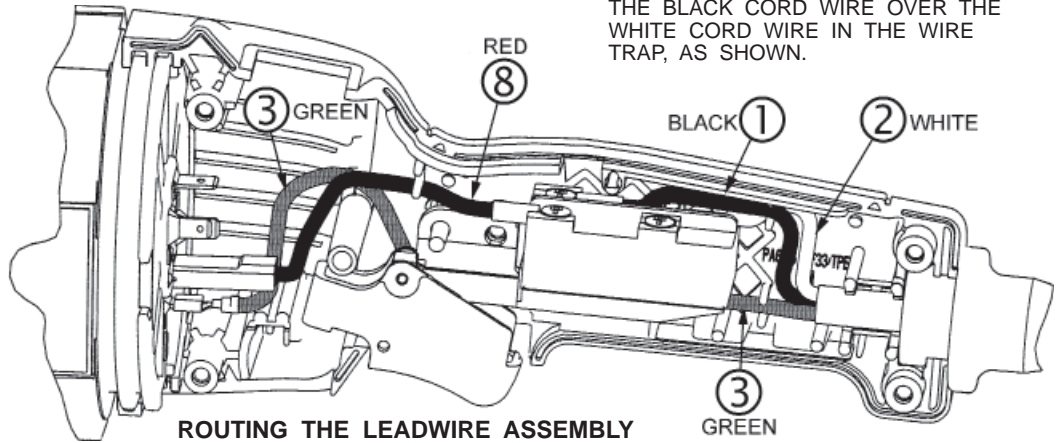

**ROUTING THE LEADWIRE ASSEMBLY**

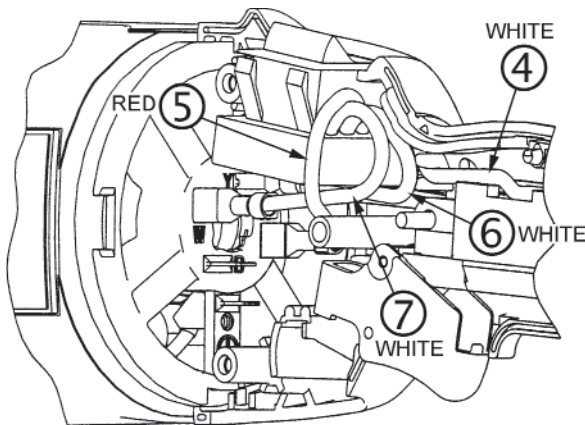

**ROUTING THE REVERSE SWITCH WIRES**

ROUTE THE RED WIRE (5), WITH THE .187 QUICK CONNECT RECEPTACLE (THIS WIRE MAY BE WHITE WITH A RED INSULATED TERMINAL) OVER WHITE WIRES (6 AND 7) AND IN FRONT OF THE WIRE GUIDE POST, AS SHOWN.

ROUTE THE WHITE WIRE (4), WITH THE RING TERMINAL, THROUGH THE WIRE TRAP TO THE ON/OFF SWITCH, AS SHOWN.

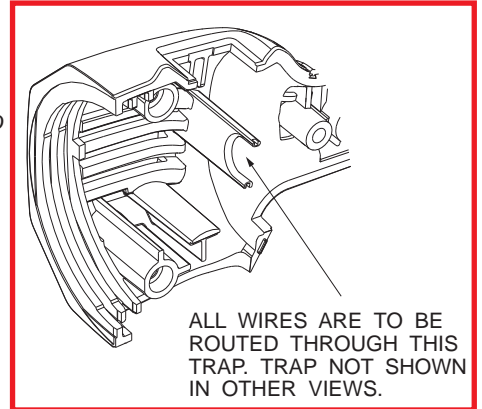

ALL WIRES ARE TO BE ROUTED THROUGH THIS TRAP. TRAP NOT SHOWN IN OTHER VIEWS.

**FIELD NOTE:**

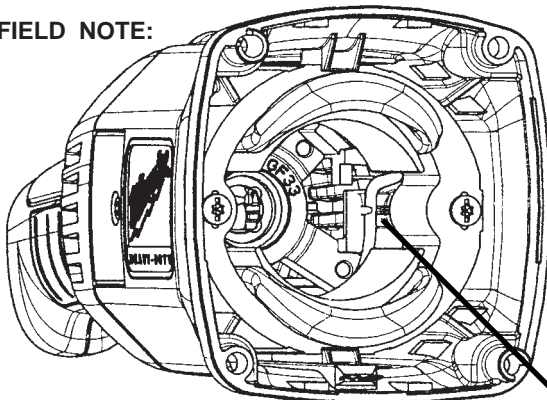

AFTER INSTALLING THE FIELD INTO THE MOTOR HOUSING, ENSURE THAT THE FIELD LEADWIRE IS ROUTED THROUGH THE WIRE TRAP AND IS HELD SECURELY. THE FIELD AND LEADWIRE MAY BE INSTALLED 180° FROM THE ORIENTATION SHOWN.

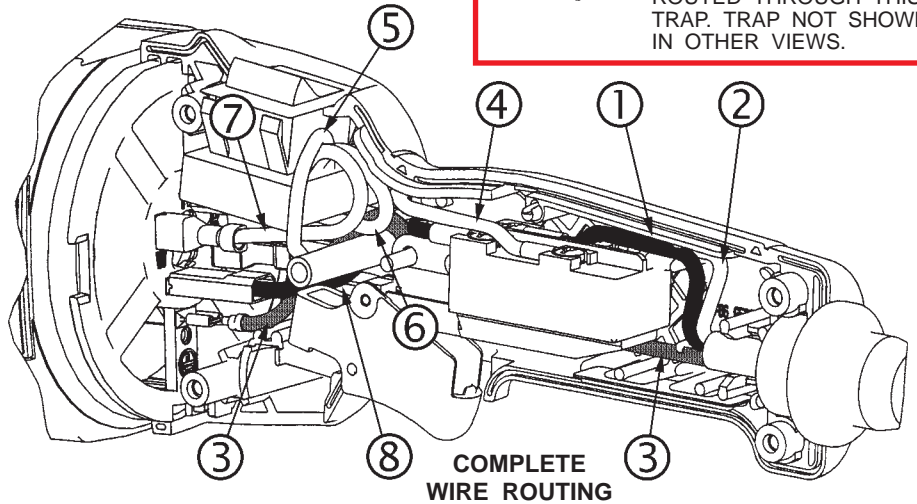

**COMPLETE WIRE ROUTING**

