



# SERVICE PARTS LIST

**BULLETIN NO.**  
54-10-0110

SPECIFY CATALOG NO. AND SERIAL NO. WHEN ORDERING PARTS		REVISED BULLETIN
<b>1/2" REVERSING COMPACT DRILL</b>		
<b>CATALOG NO. 1630-1</b>	<b>STARTING SERIAL NO. 718-1001</b>	<b>WIRING INSTRUCTION 58-01-0537</b>
<b>CAT. NO. 1630-6</b>	<b>START SER. NO. 718-1001</b>	<b>BILINGUAL LABEL 10-98-6400</b>

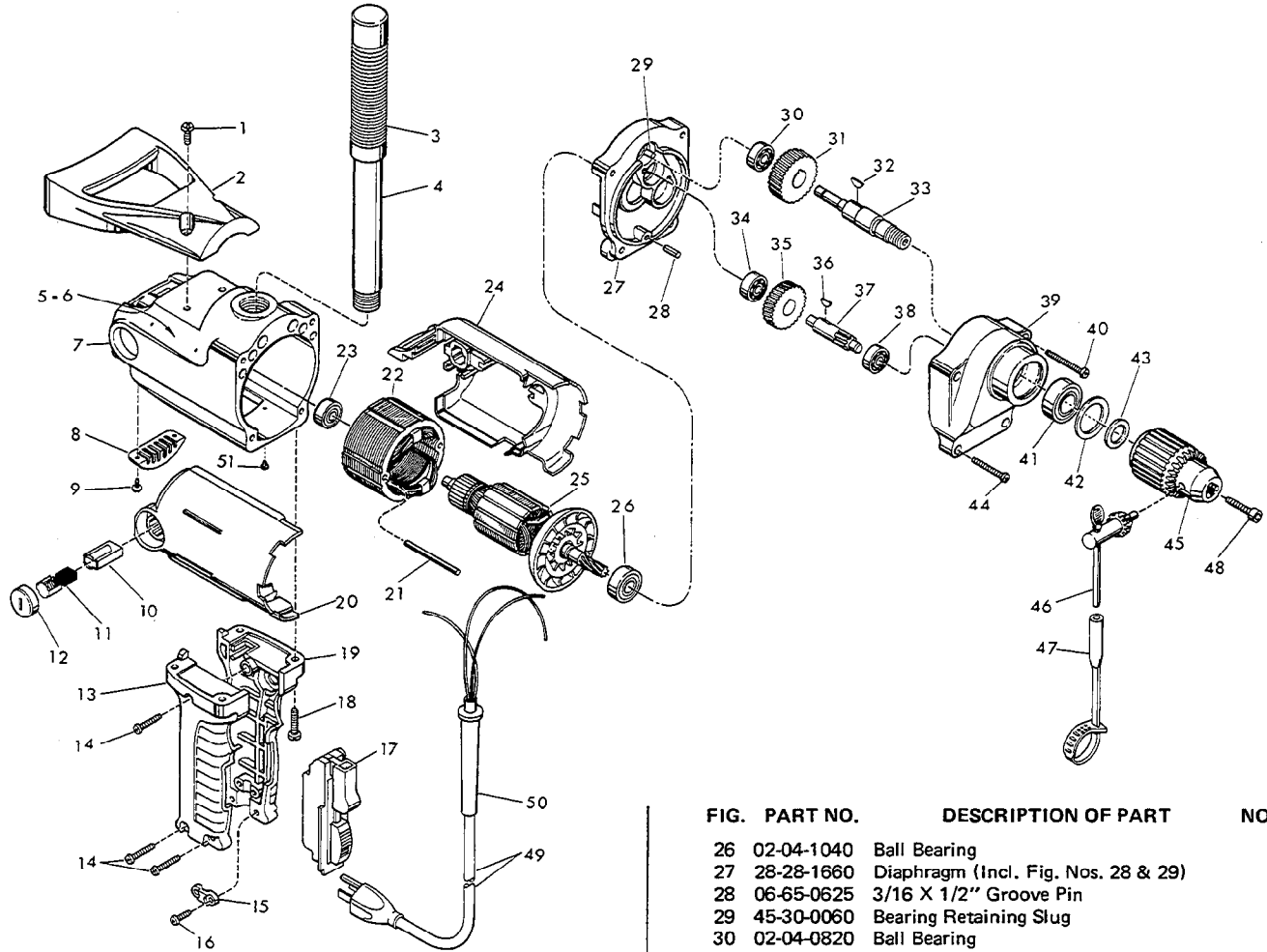

FIG.	PART NO.	DESCRIPTION OF PART	NO. REQ.
1	06-95-0460	12-24 X 3/4" Pan Hd. Taptite Sem.	(2)
2	31-44-1370	Spade handle	(1)
3	43-62-0242	Handle Grip	(1)
4	43-62-0235	Pipe Handle	(1)
5	12-99-0320	Nameplate Blank	(1)
6	06-85-0200	6 X 1/4" Nameplate Screw	(2)
7	28-50-6270	Motor Housing	(1)
8	44-66-5510	Cover Plate	(1)
9	06-95-2100	6-32 X 1/4" Pan Hd. Taptite Sem.	(2)
10	22-20-0660	Brush Tube	(2)
11	22-18-0680	Carbon Brush Assembly	(2)
12	23-44-0180	Brush Retaining Screw	(2)
13	31-44-1290	Right Hand Handle Half	(1)
14	06-95-0219	8-16 X 7/8" Plastite Screw	(3)
15	31-17-0156	Cord Clamp	(1)
16	06-95-0216	8-16 X 5/8" Plastite Screw	(2)
17	23-66-1020	On-Off 2 Speed Switch	(1)
18	06-95-0460	12-24 X 3/4" Pan Hd. Taptite Sem.	(4)
19	31-44-1295	Left Hand Handle Half	(1)
20	23-16-1275	Motor Insulator - Right Half	(1)
21	06-65-1230	Grooved Pin	(2)
22	18-50-0050	120V Field (Includes Fig. No. 21)	(1)
23	02-04-0847	Ball Bearing	(1)
24	23-16-1276	Motor Insulator - Left Half	(1)
25	16-50-0050	120V Armature (Incl. 22-84-0660 Fan)	(1)

FIG.	PART NO.	DESCRIPTION OF PART	NO. REQ.
26	02-04-1040	Ball Bearing	(1)
27	28-28-1660	Diaphragm (Incl. Fig. Nos. 28 & 29)	(1)
28	06-65-0625	3/16 X 1/2" Groove Pin	(1)
29	45-30-0060	Bearing Retaining Slug	(2)
30	02-04-0820	Ball Bearing	(1)
31	32-75-2101	Spindle Gear	(1)
32	06-42-2000	Woodruff Key	(1)
33	38-50-5430	Spindle	(1)
34	02-04-0820	Ball Bearing	(1)
35	32-40-1880	Intermediate Gear	(1)
36	06-42-1200	Woodruff Key	(1)
37	36-66-3101	Intermediate Shaft	(1)
38	02-04-0820	Ball Bearing	(1)
39	28-14-1705	Gear Case Assy. (See Note)	(1)
40	06-95-1650	10-24 X 1-7/16" Fil. Hd. Taptite Sem.	(2)
41	02-04-1567	Ball Bearing	(1)
42	34-80-2500	Retaining Ring	(1)
43	45-88-0325	Chuck Washer	(1)
44	06-95-1625	10-24 X 1-3/16" Fil. Hd. Taptite Sem.	(2)
45	48-66-1380	1/2" Rev. Chuck (Incl. Fig. No. 46)	(1)
46	48-66-3280	Chuck Key	(1)
47	48-66-4040	Key Holder	(1)
48	06-75-3150	1/4-20 X 1" Skt. Hd. Cap Screw - L.H. Thread	(1)
49	22-64-0121	Cord Set	(1)
50	44-76-0150	Cord Protector	(1)
51	06-81-8625	6-32 X 1/4 Ground Sem.	(1)
52	10-98-5987	Warning Label (Not Shown)	(1)

**NOTE:**  
**LUBRICATION**  
5-1/2 Oz. Type A



# SERVICE PARTS LIST

**BULLETIN NO.**  
54-10-0111

SPECIFY CATALOG NO. AND SERIAL NO. WHEN ORDERING PARTS		REVISED BULLETIN 54-10-0110	DATE April '86
<b>1/2" REVERSING COMPACT DRILL</b>			
<b>CATALOG NO. 1630-1</b>		<b>STARTING SERIAL NO. 718-8206</b>	
		<b>WIRING INSTRUCTION 58-01-0537</b>	
CAT. NO.	START SER. NO.	BILINGUAL LABEL	

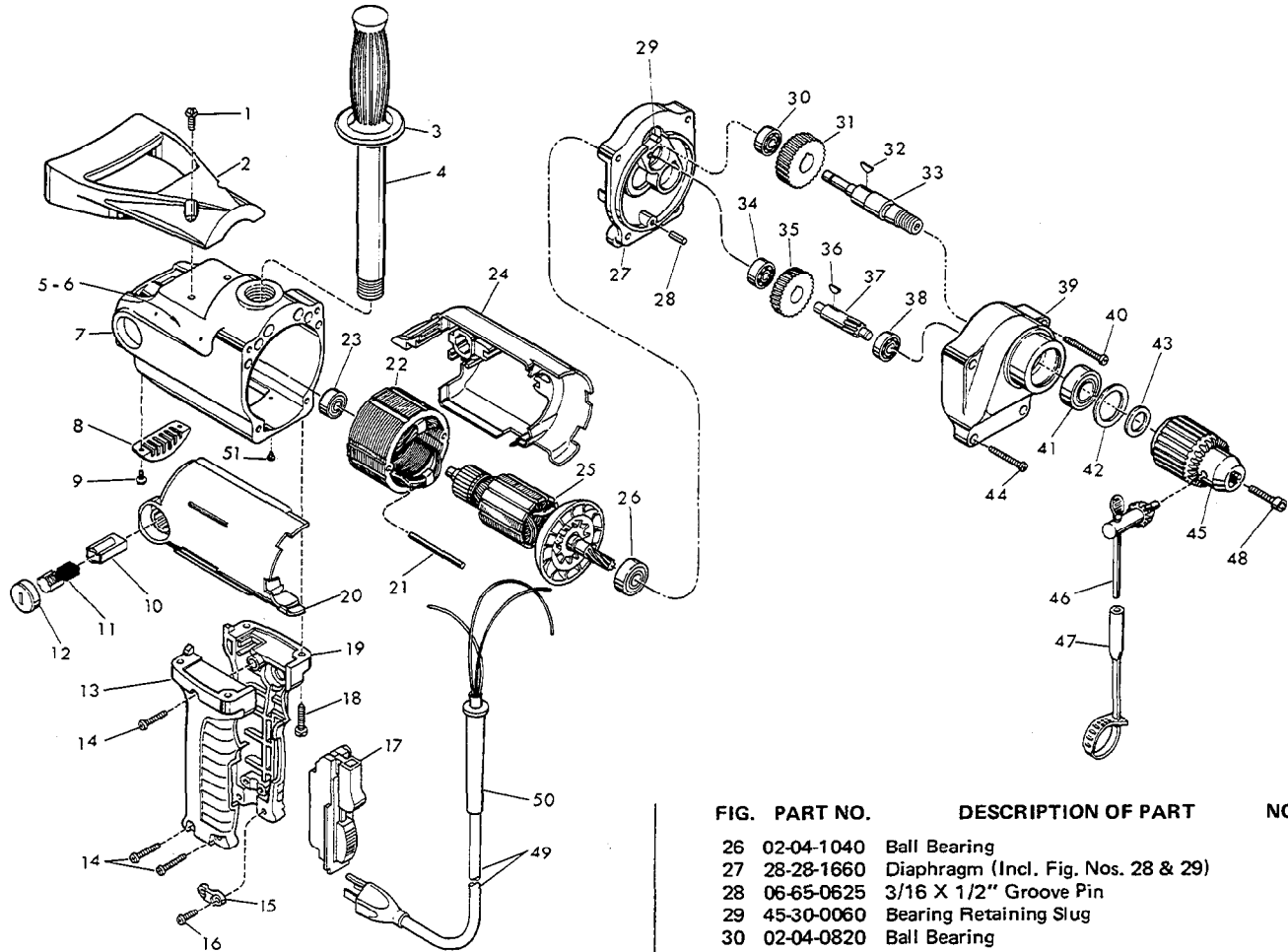

FIG.	PART NO.	DESCRIPTION OF PART	NO. REQ.
	1	06-95-0460 12-24 X 3/4" Pan Hd. Taptite Sem.	(2)
	2	31-44-1370 Spade handle	(1)
★	3	43-62-0246 Handle Grip	(1)
	4	43-62-0235 Pipe Handle	(1)
	5	12-99-0320 Nameplate Blank	(1)
	6	06-85-0200 6 X 1/4" Nameplate Screw	(2)
	7	28-50-6270 Motor Housing	(1)
	8	44-66-5510 Cover Plate	(1)
	9	06-95-2100 6-32 X 1/4" Pan Hd. Taptite Sem.	(2)
	10	22-20-0660 Brush Tube	(2)
	11	22-18-0680 Carbon Brush Assembly	(2)
	12	23-44-0180 Brush Retaining Screw	(2)
★	13	31-44-1440 Right Hand Handle Half	(1)
★	14	06-82-7326 8-26 X 1" Plastite Screw	(3)
	15	31-17-0156 Cord Clamp	(1)
	16	06-95-0216 8-16 X 5/8" Plastite Screw	(2)
	17	23-66-1020 On-Off 2 Speed Switch	(1)
	18	06-95-0460 12-24 X 3/4" Pan Hd. Taptite Sem.	(4)
★	19	31-44-1445 Left Hand Handle Half	(1)
	20	23-16-1275 Motor Insulator - Right Half	(1)
	21	06-65-1230 Grooved Pin	(2)
	22	18-50-0050 120V Field (Includes Fig. No. 21)	(1)
	23	02-04-0847 Ball Bearing	(1)
	24	23-16-1276 Motor Insulator - Left Half	(1)
	25	16-50-0050 120V Armature (Incl. 22-84-0660 Fan)	(1)

FIG.	PART NO.	DESCRIPTION OF PART	NO. REQ.
	26	02-04-1040 Ball Bearing	(1)
	27	28-28-1660 Diaphragm (Incl. Fig. Nos. 28 & 29)	(1)
	28	06-65-0625 3/16 X 1/2" Groove Pin	(1)
	29	45-30-0060 Bearing Retaining Slug	(2)
	30	02-04-0820 Ball Bearing	(1)
	31	32-75-2101 Spindle Gear	(1)
	32	06-42-2000 Woodruff Key	(1)
	33	38-50-5430 Spindle	(1)
	34	02-04-0820 Ball Bearing	(1)
	35	32-40-1880 Intermediate Gear	(1)
	36	06-42-1200 Woodruff Key	(1)
	37	36-66-3101 Intermediate Shaft	(1)
	38	02-04-0820 Ball Bearing	(1)
	39	28-14-1705 Gear Case Assy. (See Note)	(1)
	40	06-95-1650 10-24 X 1-7/16" Fil. Hd. Taptite Sem.	(2)
	41	02-04-1567 Ball Bearing	(1)
	42	34-80-2500 Retaining Ring	(1)
	43	45-88-0325 Chuck Washer	(1)
	44	06-95-1625 10-24 X 1-3/16" Fil. Hd. Taptite Sem.	(2)
	45	48-66-1380 1/2" Rev. Chuck (Incl. Fig. No. 46)	(1)
	46	48-66-3280 Chuck Key	(1)
	47	48-66-4040 Key Holder	(1)
	48	06-75-3150 1/4-20 X 1" Skt. Hd. Cap Screw - L.H. Thread	(1)
	49	22-64-0121 Cord Set	(1)
	50	44-76-0150 Cord Protector	(1)
	51	06-81-8625 6-32 X 1/4 Ground Sem.	(1)
	52	10-98-5986 Warning Label (Not Shown)	(1)

**NOTE:**  
**LUBRICATION**  
5-1/2 Oz. Type A



# SERVICE PARTS LIST

BULLETIN NO.  
54-10-0112

SPECIFY CATALOG NO. AND SERIAL NO. WHEN ORDERING PARTS		REVISED BULLETIN	DATE
1/2" REVERSING COMPACT DRILL		54-10-0111	Feb. '88
CATALOG NO. 1630-1	STARTING SERIAL NO. 718-15756	WIRING INSTRUCTION 58-01-0537	

**EXAMPLE:**  
Component Parts (Small #) Are Included When Ordering The Assembly (Large #).

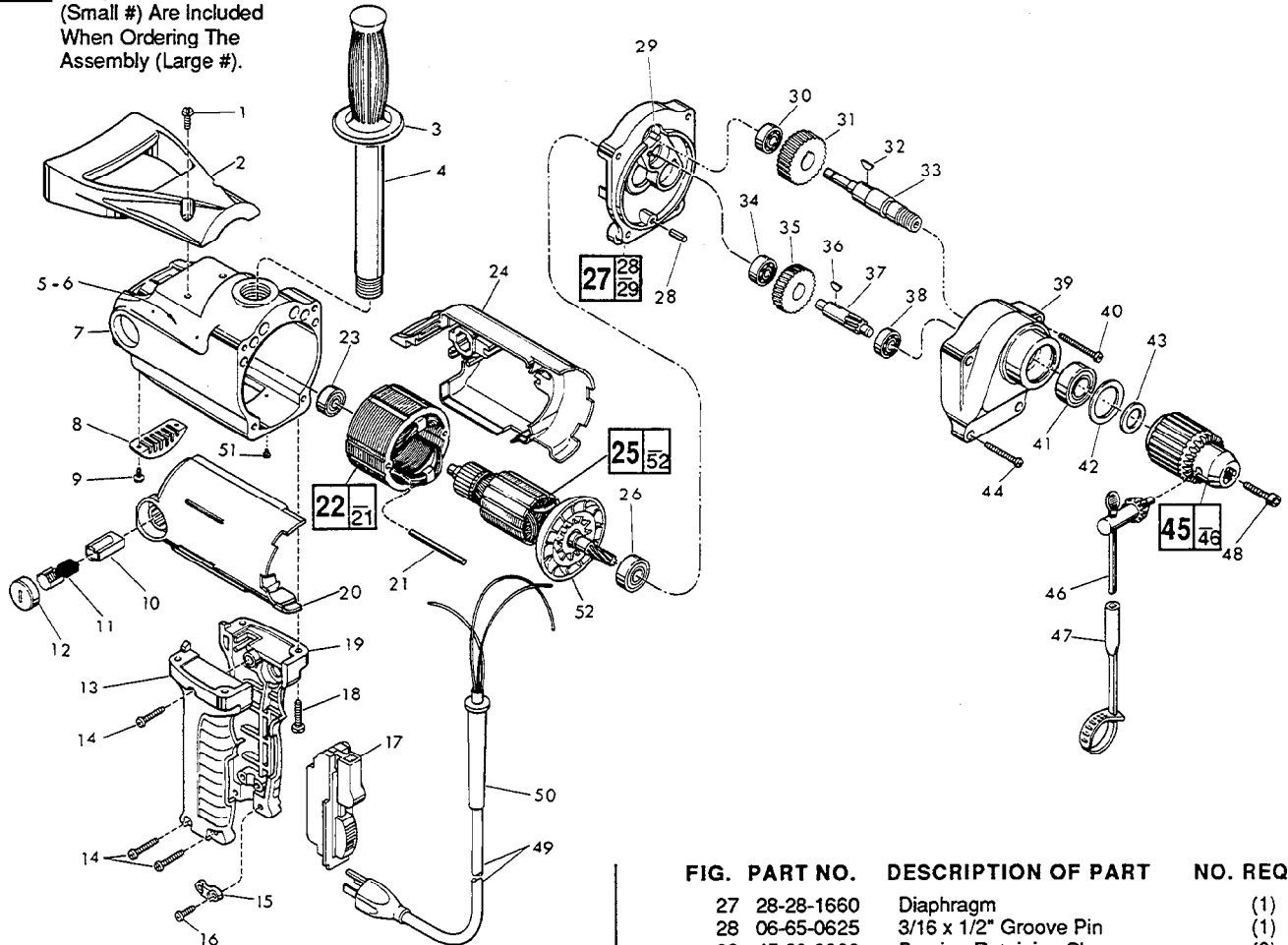

FIG. PART NO.	DESCRIPTION OF PART	NO. REQ.
1	06-95-0460 12-24x3/4" Pan Hd. Taptite Sem.	(2)
2	31-44-1370 Spade Handle	(1)
3	43-62-0246 Handle Grip	(1)
4	43-62-0235 Pipe Handle	(1)
5	12-99-0320 Nameplate Blank	(1)
6	06-85-0200 6x1/4" Nameplate Screw	(2)
7	28-50-6270 Motor Housing	(1)
8	44-66-5510 Cover Plate	(1)
9	06-95-2100 6-32x1/4" Pan Hd. Taptite Sem.	(2)
10	22-20-0660 Brush Tube	(2)
11	22-18-0680 Carbon Brush Assembly	(2)
12	23-44-0180 Brush Retaining Screw	(2)
13	31-44-1440 Right Hand Handle Half	(1)
14	06-82-7326 8-16x1" Plastite Screw	(3)
15	31-17-0156 Cord Clamp	(1)
16	06-95-0216 8-16x5/8" Plastite Screw	(2)
17	23-66-1020 On-Off 2 Speed Switch	(1)
18	06-95-0460 12-24x3/4" Pan Hd. Taptite Sem.	(4)
19	31-44-1445 Left Hand Handle Half	(1)
20	23-16-1275 Motor Insulator - Right Half	(1)
21	06-65-1230 Grooved Pin	(2)
22	18-50-0050 120 V. Field	(1)
23	02-04-0847 Ball Bearing	(1)
24	23-16-1276 Motor Insulator - Left Half	(1)
25	16-50-0050 120 V. Armature	(1)
26	02-04-1040 Ball Bearing	(1)

FIG. PART NO.	DESCRIPTION OF PART	NO. REQ.
27	28-28-1660 Diaphragm	(1)
28	06-65-0625 3/16 x 1/2" Groove Pin	(1)
29	45-30-0060 Bearing Retaining Slug	(2)
30	02-04-0820 Ball Bearing	(1)
31	32-75-2101 Spindle Gear	(1)
32	06-42-2000 Woodruff Key	(1)
33	38-50-5430 Spindle	(1)
34	02-04-0820 Ball Bearing	(1)
35	32-40-1880 Intermediate Gear	(1)
36	06-42-1200 Woodruff Key	(1)
37	36-66-3101 Intermediate Shaft	(1)
38	02-04-0820 Ball Bearing	(1)
39	28-14-1705 Gear Case Assembly	(1)
40	06-95-1650 10-24x1-7/16" Fil. Hd. Taptite Sem	(2)
41	02-04-1567 Ball Bearing	(1)
42	34-80-2500 Retaining Ring	(1)
★ 43	45-88-0330 Chuck Washer	(1)
44	06-95-1625 10-24x1-3/16" Fil. Hd. Taptite Sem.	(2)
★ 45	48-66-1381 1/2" Reversing Chuck	(1)
46	48-66-3280 Chuck Key	(1)
47	48-66-4040 Key Holder	(1)
48	06-75-3150 1/4-20x1" Skt. Hd. Cap Screw - L.H. Thread	(1)
49	22-64-0121 Cord Set	(1)
50	44-76-0150 Cord Protector	(1)
51	06-81-8625 6-32x1/4" Ground Sem.	(1)
52	22-84-0660 Fan	(1)
	10-98-5986 Warning Label	(1)

### FIG. LUBRICATION

39 5-1/2 Oz. Type "A" Grease, 49-08-0800.



# SERVICE PARTS LIST

BULLETIN NO.  
54-10-0113

SPECIFY CATALOG NO. AND SERIAL NO. WHEN ORDERING PARTS		REVISED BULLETIN	DATE
1/2" REVERSING COMPACT DRILL		54-10-0112	Mar. '88
CATALOG NO. 1630-1	STARTING SERIAL NO. 718-20000	WIRING INSTRUCTION 58-01-0537	

**EXAMPLE:**  
Component Parts  
(Small #) Are Included  
When Ordering The  
Assembly (Large #).

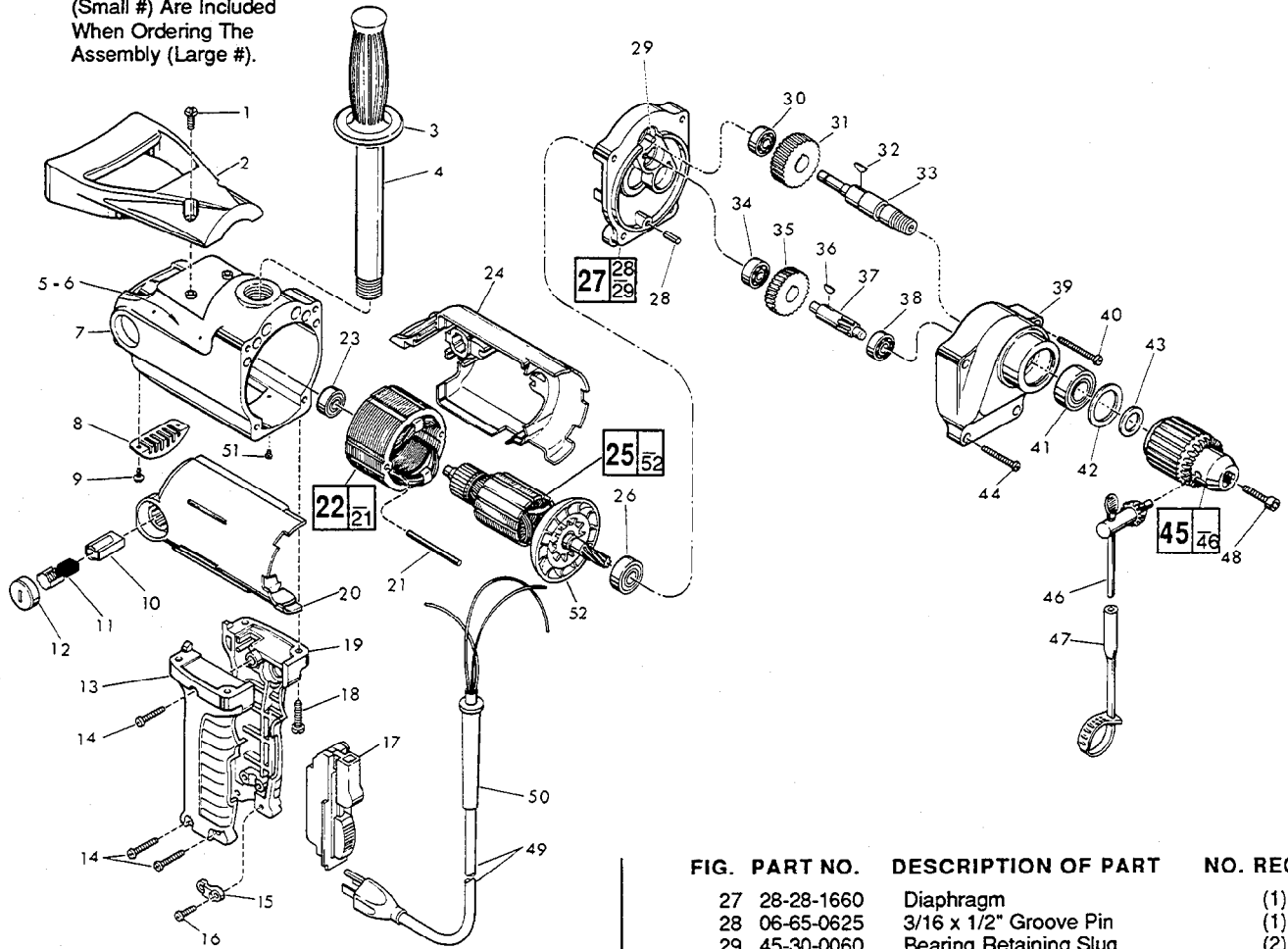

FIG. PART NO.	DESCRIPTION OF PART	NO. REQ.
1	06-95-0460 12-24x3/4" Pan Hd. Taptite Sem.	(2)
★2	31-44-1550 Spade Handle	(1)
3	43-62-0246 Handle Grip	(1)
4	43-62-0235 Pipe Handle	(1)
5	12-99-0320 Nameplate Blank	(1)
6	06-85-0200 6x1/4" Nameplate Screw	(2)
★7	26-50-6295 Motor Housing	(1)
8	44-66-5510 Cover Plate	(1)
9	06-95-2100 6-32x1/4" Pan Hd. Taptite Sem.	(2)
10	22-20-0660 Brush Tube	(2)
11	22-18-0680 Carbon Brush Assembly	(2)
12	23-44-0180 Brush Retaining Screw	(2)
13	31-44-1440 Right Hand Handle Half	(1)
14	06-82-7326 8-16x1" Plastite Screw	(3)
15	31-17-0156 Cord Clamp	(1)
16	06-95-0216 8-16x5/8" Plastite Screw	(2)
17	23-66-1020 On-Off 2 Speed Switch	(1)
18	06-95-0460 12-24x3/4" Pan Hd. Taptite Sem.	(4)
19	31-44-1445 Left Hand Handle Half	(1)
20	23-16-1275 Motor Insulator - Right Half	(1)
21	06-65-1230 Grooved Pin	(2)
22	18-50-0050 120 V. Field	(1)
23	02-04-0847 Ball Bearing	(1)
24	23-16-1276 Motor Insulator - Left Half	(1)
25	16-50-0050 120 V. Armature	(1)
26	02-04-1040 Ball Bearing	(1)

FIG. PART NO.	DESCRIPTION OF PART	NO. REQ.
27	28-28-1660 Diaphragm	(1)
28	06-65-0625 3/16 x 1/2" Groove Pin	(1)
29	45-30-0060 Bearing Retaining Slug	(2)
30	02-04-0820 Ball Bearing	(1)
31	32-75-2101 Spindle Gear	(1)
32	06-42-2000 Woodruff Key	(1)
33	38-50-5430 Spindle	(1)
34	02-04-0820 Ball Bearing	(1)
35	32-40-1880 Intermediate Gear	(1)
36	06-42-1200 Woodruff Key	(1)
37	36-66-3101 Intermediate Shaft	(1)
38	02-04-0820 Ball Bearing	(1)
39	28-14-1705 Gear Case Assembly	(1)
40	06-95-1650 10-24x1-7/16" Fil. Hd. Taptite Sem	(2)
41	02-04-1567 Ball Bearing	(1)
42	34-80-2500 Retaining Ring	(1)
43	45-88-0330 Chuck Washer	(1)
44	06-95-1625 10-24x1-3/16" Fil. Hd. Taptite Sem.	(2)
45	48-66-1381 1/2" Reversing Chuck	(1)
46	48-66-3280 Chuck Key	(1)
47	48-66-4040 Key Holder	(1)
48	06-75-3150 1/4-20x1" Skt. Hd. Cap Screw - L.H. Thread	(1)
49	22-64-0121 Cord Set	(1)
50	44-76-0150 Cord Protector	(1)
51	06-81-8625 6-32x1/4" Ground Sem.	(1)
52	22-84-0660 Fan	(1)
	10-98-5986 Warning Label	(1)

**FIG. LUBRICATION**

39 5-1/2 Oz. Type "A" Grease, 49-08-0800.



# SERVICE PARTS LIST

BULLETIN NO.  
54-10-0114

SPECIFY CATALOG NO. AND SERIAL NO. WHEN ORDERING PARTS		REVISED BULLETIN	DATE
<b>1/2" REVERSING COMPACT DRILL</b>		54-10-0113	Mar.'94
CATALOG NO. 1630-1	STARTING SERIAL NO. 718A	WIRING INSTRUCTION	
		58-01-0537	

00 0

EXAMPLE:  
Component Parts  
(Small #) Are Included  
When Ordering The  
Assembly (Large #).

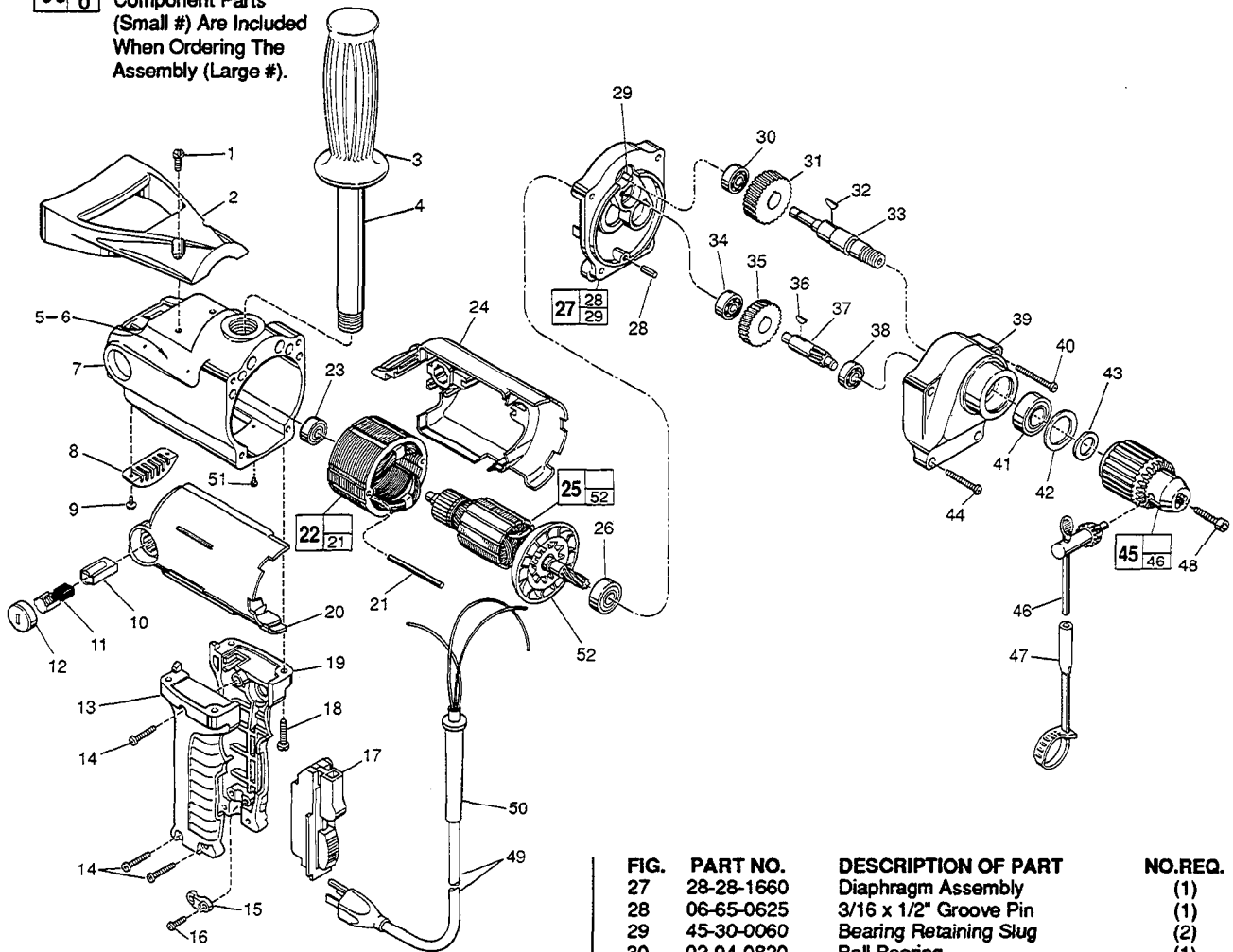

FIG.	PART NO.	DESCRIPTION OF PART	NO.REQ.
★ 1	06-82-8908	12-24 x 3/4" Pan Hd. Slit. Tapt. T-27	(2)
2	31-44-1550	Spade Handle	(1)
3	43-62-0246	Handle Grip	(1)
★ 4	43-62-0122	Pipe Handle	(1)
★ 5	12-99-3150	Nameplate Blank	(1)
6	06-85-0200	6 x 1/4" Nameplate Screw	(2)
7	26-50-6295	Motor Housing	(1)
8	44-66-5510	Cover Plate	(1)
★ 9	06-82-5270	6-32 x 1/4" Pan Hd. Slit. Tapt. T-15	(2)
10	22-20-0660	Brush Tube	(2)
11	22-18-0680	Carbon Brush Assembly	(2)
★ 12	23-44-0210	Brush Retaining Screw	(2)
13	31-44-1440	Right Hand Handle Half	(1)
14	06-82-7326	8-16 x 1" Plastite T-20 Screw	(3)
15	31-17-0156	Cord Clamp	(1)
★ 16	06-82-7270	8-16 x 5/8" Slit. Pan Hd. Plast. T-20	(2)
17	23-66-1020	On-Off 2 Speed Switch	(1)
★ 18	06-82-8908	12-24 x 3/4" Pan Hd. Slit. Taptite T-27	(4)
19	31-44-1445	Left Hand Handle Half	(1)
20	23-16-1275	Motor Insulator Right Half	(1)
21	06-65-1230	Grooved Pin	(2)
22	18-50-0050	120 V. Field	(1)
23	02-04-0847	Ball Bearing	(1)
24	23-16-1276	Motor Insulator - Left Half	(1)
25	16-50-0050	120 V. Armature	(1)
★ 26	02-04-1050	Ball Bearing	(1)

FIG.	PART NO.	DESCRIPTION OF PART	NO.REQ.
27	28-28-1660	Diaphragm Assembly	(1)
28	06-65-0625	3/16 x 1/2" Groove Pin	(1)
29	45-30-0060	Bearing Retaining Slug	(2)
30	02-04-0820	Ball Bearing	(1)
31	32-75-2101	Spindle Gear	(1)
32	06-42-2000	Woodruff Key	(1)
33	38-50-5430	Spindle	(1)
34	02-04-0820	Ball Bearing	(1)
35	32-40-1880	Intermediate Gear	(1)
36	06-42-1200	Woodruff Key	(1)
37	36-66-3101	Intermediate Shaft	(1)
38	02-04-0820	Ball Bearing	(1)
39	28-14-1705	Gear Case Assembly	(1)
★ 40	06-82-7784	10-24 x 1-7/16" Tapt. T-27	(2)
41	02-04-1567	Ball Bearing	(1)
42	34-80-2500	Retaining Ring	(1)
43	45-88-0330	Chuck Washer	(1)
★ 44	06-82-7752	10-24 x 1-3/16" Taptite Sem.T-27	(2)
45	48-66-1381	1/2" Reversing Chuck	(1)
46	48-66-3280	Chuck Key	(1)
47	48-66-4040	Key Holder	(1)
48	06-75-3150	1/4-20 x 1" Skt. Hd. Cap Screw-L.H.Thread	(1)
49	22-64-0121	Cord Set	(1)
50	44-76-0150	Cord Protector	(1)
★ 51	06-95-5150	6-32 x 1/4" Hex Hd. Tapt. Sems	(1)
52	22-84-0660	Fan	(1)
	10-98-5986	Warning Label	(1)

FIG. LUBRICATION  
39 5-1/2 Oz. Type "A" Grease, 49-08-0800.



# SERVICE PARTS LIST

**BULLETIN NO.**  
**54-10-0115**

<b>SPECIFY CATALOG NO. AND SERIAL NO. WHEN ORDERING PARTS</b>		REVISED BULLETIN	DATE
<b>1/2" REVERSING COMPACT DRILL</b>		54-10-0114	May 2006
CATALOG NO.	1630-1	WIRING INSTRUCTION	
STARTING SERIAL NO.	718B	<b>58-01-0537</b>	

**EXAMPLE:**  
Component Parts (Small #) Are Included When Ordering The Assembly (Large #).

**RECALL NOTICE!**  
See back page for important safety information.

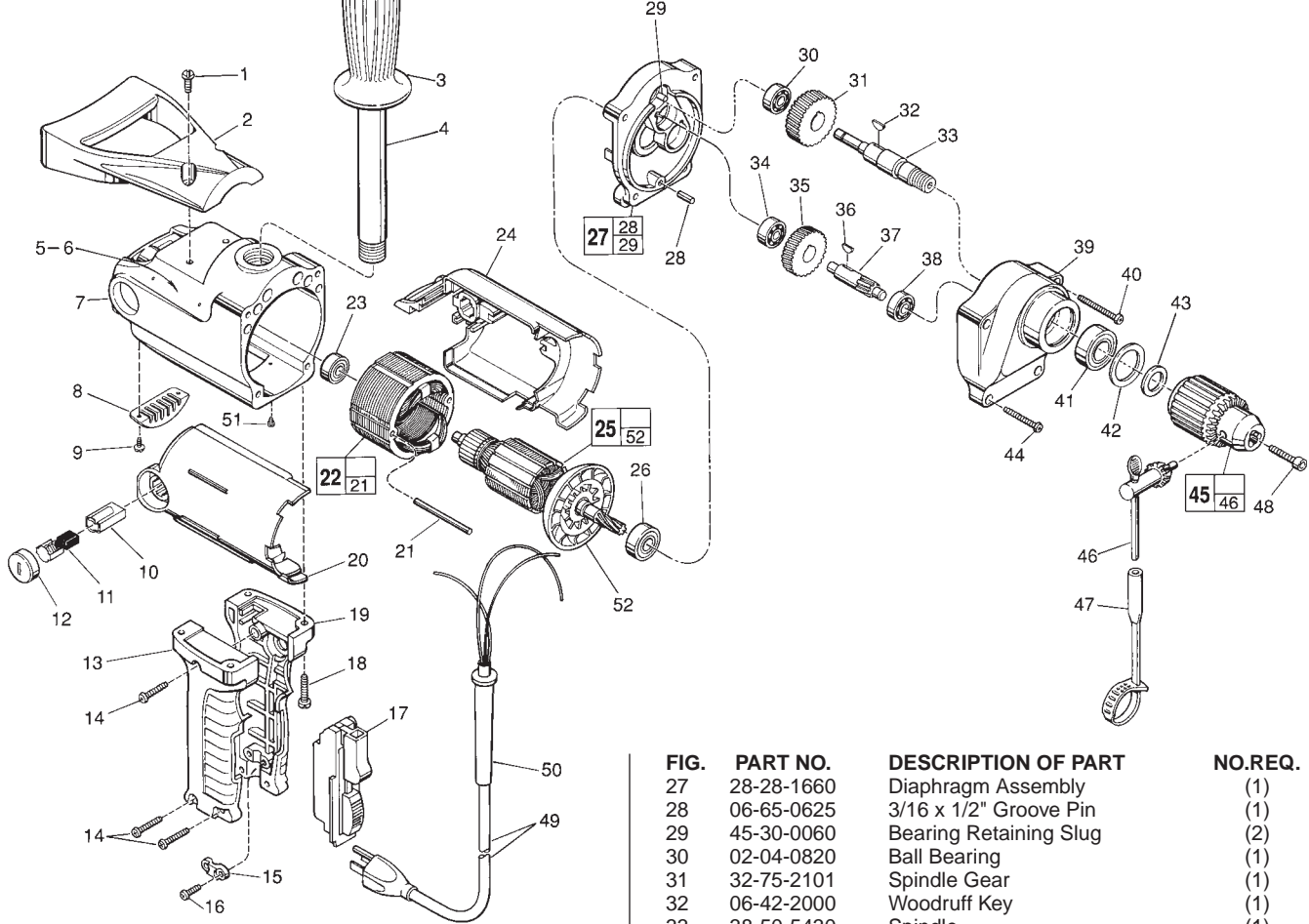

FIG.	PART NO.	DESCRIPTION OF PART	NO.REQ.
1	06-82-8908	12-24 x 3/4" Pan Hd. Slit. Tapt. T-27	(2)
2	31-44-1550	Spade Handle	(1)
3	43-62-0246	Handle Grip	(1)
4	43-62-0122	Pipe Handle	(1)
5	12-99-3150	Nameplate Blank	(1)
6	06-85-0200	6 x 1/4" Nameplate Screw	(2)
★ 7	26-50-6300	Motor Housing	(1)
8	44-66-5510	Cover Plate	(1)
9	06-82-5270	6-32 x 1/4" Pan Hd. Slit. Tapt. T-15	(2)
10	22-20-0660	Brush Tube	(2)
11	22-18-0680	Carbon Brush Assembly	(2)
12	23-44-0210	Brush Retaining Screw	(2)
★ 13	31-44-1441	Right Hand Handle Half	(1)
14	06-82-7326	8-16 x 1" Plastite T-20 Screw	(3)
15	31-17-0155	Cord Clamp	(1)
16	06-82-7270	8-16 x 5/8" Slit. Pan Hd. Plast. T-20	(2)
17	23-66-1020	On-Off 2 Speed Switch	(1)
★ 18	06-82-5382	1/4-20 x 3/4" Pan Hd. Slit. Taptite T-27	(4)
★ 19	31-44-1446	Left Hand Handle Half	(1)
20	23-16-1275	Motor Insulator Right Half	(1)
21	06-65-1230	Grooved Pin	(2)
22	18-50-0050	120 V. Field	(1)
23	02-04-0847	Ball Bearing	(1)
24	23-16-1276	Motor Insulator - Left Half	(1)
25	16-50-1050	120 V. Armature	(1)
26	02-04-1050	Ball Bearing	(1)

FIG.	PART NO.	DESCRIPTION OF PART	NO.REQ.
27	28-28-1660	Diaphragm Assembly	(1)
28	06-65-0625	3/16 x 1/2" Groove Pin	(1)
29	45-30-0060	Bearing Retaining Slug	(2)
30	02-04-0820	Ball Bearing	(1)
31	32-75-2101	Spindle Gear	(1)
32	06-42-2000	Woodruff Key	(1)
33	38-50-5430	Spindle	(1)
34	02-04-0820	Ball Bearing	(1)
35	32-40-1880	Intermediate Gear	(1)
36	06-42-1200	Woodruff Key	(1)
37	36-66-3101	Intermediate Shaft	(1)
38	02-04-0820	Ball Bearing	(1)
39	28-14-1705	Gear Case Assembly	(1)
40	06-82-7784	10-24 x 1-7/16" Tapt. T-27	(2)
41	02-04-1567	Ball Bearing	(1)
42	34-80-2500	Retaining Ring	(1)
43	45-88-0330	Chuck Washer	(1)
44	06-82-7752	10-24 x 1-3/16" Taptite Sem.T-27	(2)
45	48-66-1381	1/2" Reversing Chuck	(1)
46	48-66-3280	Chuck Key	(1)
47	48-66-4040	Key Holder	(1)
48	06-75-3150	1/4-20 x 1" Skt. Hd. Cap Screw L.H.	(1)
49	22-64-0121	Cord Set	(1)
50	44-76-0150	Cord Protector	(1)
51	06-95-5150	6-32 x 1/4" Hex Hd. Tapt. Sems	(1)
52	22-84-0660	Fan	(1)
★	10-98-5986	Warning Label	(1)
★	10-98-5984	French/Spanish Warning Label	(1)

**FIG. LUBRICATION**  
39 5-1/2 Oz. Type "E" Grease, 49-08-4122.

## RECALL NOTICE!

Milwaukee is providing a **no-charge** warranty service to owners of **1610-1, 1630-1 1/2" Compact Hole-Shooter Drills and 1670-1, 1675-1 1/2" Hole-Hawg® Drills**. We are taking this action because under certain circumstances the switch of the drill may stick in the "on" position, which could lessen control of the product, posing a risk of injury to the operator.

**1610-1, 1630-1 1/2" Compact Hole-Shooter Drills and 1670-1, 1675-1 1/2" Hole-Hawg® Drills** within the serial number ranges shown below and sold between May 30,2000 and February 27, 2001 are affected.

Nameplate Catalog Number	Serial Number Range
1610-1	7 0 0 B 4 <u>00200013</u> thru 700B4 <u>00480097</u>
1630-1	7 1 8 B 4 <u>00230057</u> thru 718B4 <u>00480118</u>
1670-1	472B4 <u>00200061</u> thru 472B4 <u>00440188</u>
1675-1	413B4 <u>00190567</u> thru 413B4 <u>00522000</u>

**Drills** listed should **be inspected** for the presence of a **23-66-1020** Switch with a date code within 0021 through 0044. If the unit contains a subject dated coded 23-66-1020 switch, please return drill to the nearest Milwaukee **factory** Service Center or Authorized Service station for no-charge warranty replacement of the switch.

Affected switches carry a manufacture's four [4] digit **date code of 0021 t h r u 0044** imprinted on its body.

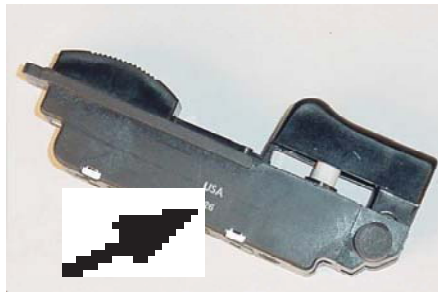

If nameplate has an '**X**' stamped into the tool's nameplate, next to the catalog number, the tool has been repaired and the defective switch has already been replaced.



# SERVICE PARTS LIST

**BULLETIN NO.**  
**54-10-0116**

<b>SPECIFY CATALOG NO. AND SERIAL NO. WHEN ORDERING PARTS</b>		REVISED BULLETIN	DATE
<b>1/2" REVERSING COMPACT DRILL</b>		54-10-0115	Feb. 2012
<b>CATALOG NO.</b>	<b>1630-1</b>	WIRING INSTRUCTION	
<b>STARTING SERIAL NO.</b>	<b>718C</b>	<b>58-01-0537</b>	

00 0

**EXAMPLE:**  
Component Parts (Small #)  
Are Included When Ordering  
The Assembly (Large #).

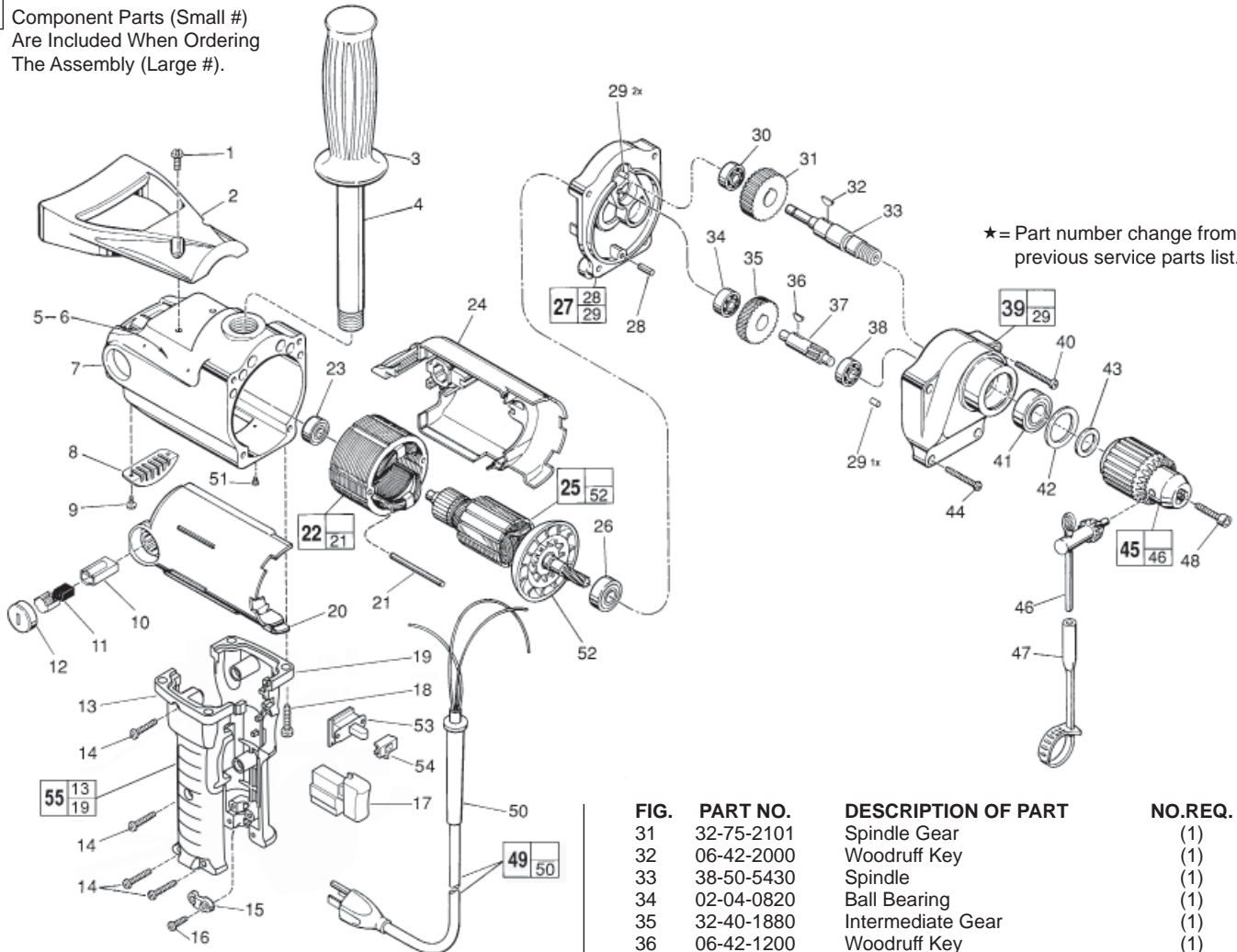

★ = Part number change from previous service parts list.

FIG.	PART NO.	DESCRIPTION OF PART	NO.REQ.
	1	06-82-8908 12-24 x 3/4" Pan Hd. Slit. Tapt. T-27	(2)
	2	31-44-1550 Spade Handle	(1)
	3	43-62-0246 Handle Grip	(1)
	4	43-62-0122 Pipe Handle	(1)
	5	12-99-3150 Nameplate Blank	(1)
★	6	06-95-0500 4-40 x 5/16" Tapt. Stick Screw	(2)
	7	26-50-6300 Motor Housing	(1)
	8	44-66-5510 Cover Plate	(1)
	9	06-82-5270 6-32 x 1/4" Pan Hd. Slit. Tapt. T-15	(2)
	10	22-20-0660 Brush Tube	(2)
	11	22-18-0680 Carbon Brush Assembly	(2)
	12	23-44-0210 Brush Retaining Screw	(2)
★	13	Right Hand Handle Half	(1)
★	14	06-82-7326 8-16 x 1" Plastite T-20 Screw	(4)
	15	31-17-0155 Cord Clamp	(1)
	16	06-82-7270 8-16 x 5/8" Slit. Pan Hd. Plast. T-20	(2)
★	17	23-66-0115 On-Off Switch	(1)
	18	06-82-5382 1/4-20 x 3/4" Pan Hd. Slit. Taptite T-27	(4)
★	19	Left Hand Handle Half	(1)
	20	23-16-1275 Motor Insulator Right Half	(1)
	21	06-65-1230 Grooved Pin	(2)
	22	18-50-0050 120 V. Field	(1)
	23	02-04-0847 Ball Bearing	(1)
	24	23-16-1276 Motor Insulator - Left Half	(1)
	25	16-50-1050 120 V. Armature	(1)
	26	02-04-1050 Ball Bearing	(1)
	27	28-28-1660 Diaphragm Assembly	(1)
	28	06-65-0625 3/16 x 1/2" Groove Pin	(1)
	29	45-30-0060 Bearing Retaining Slug	(3)
	30	02-04-0820 Ball Bearing	(1)

FIG.	PART NO.	DESCRIPTION OF PART	NO.REQ.
	31	32-75-2101 Spindle Gear	(1)
	32	06-42-2000 Woodruff Key	(1)
	33	38-50-5430 Spindle	(1)
	34	02-04-0820 Ball Bearing	(1)
	35	32-40-1880 Intermediate Gear	(1)
	36	06-42-1200 Woodruff Key	(1)
	37	36-66-3101 Intermediate Shaft	(1)
	38	02-04-0820 Ball Bearing	(1)
	39	28-14-1705 Gear Case Assembly	(1)
	40	06-82-7784 10-24 x 1-7/16" Tapt. T-27	(2)
	41	02-04-1567 Ball Bearing	(1)
	42	34-80-2500 Retaining Ring	(1)
	43	45-88-0330 Chuck Washer	(1)
	44	06-82-7752 10-24 x 1-3/16" Taptite Sem.T-27	(2)
	45	48-66-1381 1/2" Reversing Chuck	(1)
	46	48-66-3280 Chuck Key	(1)
	47	48-66-4040 Key Holder	(1)
	48	06-75-3150 1/4-20 x 1" Skt. Hd. Cap Screw L.H.	(1)
★	49	22-64-1246 Cord Set	(1)
	50	44-76-0150 Cord Protector	(1)
	51	06-95-5150 6-32 x 1/4" Hex Hd. Tapt. Sems	(1)
	52	22-84-0660 Fan	(1)
★	53	23-66-2516 Fwd./Rev. Switch	(1)
★	54	43-72-0220 Interlock	(1)
★	55	31-44-1493 Handle Set	(1)
		10-98-5986 Warning Label	(1)
★		10-98-5982 French/Spanish Warning Label	(1)

**FIG. LUBRICATION**

39 5-1/2 Oz. Type "E" Grease, 49-08-4122.