



OPERATOR'S MANUAL



Catalog No.

1001-1
1007-1
1101-1
1107-6
1107-1
1250-1

**HEAVY-DUTY, REVERSING,
1/2" D-HANDLE DRILL**

3102-1
3102-6
3002-1
3107-1
3107-6

HEAVY-DUTY, RIGHT ANGLE, REVERSING 1/2" D-HANDLE DRILL

48-06-2871

RIGHT ANGLE DRIVE UNIT

48-06-2860

33° ANGLE DRIVE UNIT

TO REDUCE THE RISK OF INJURY, USER MUST READ AND UNDERSTAND OPERATOR'S MANUAL.

GENERAL POWER TOOL SAFETY WARNINGS

WARNING READ ALL SAFETY WARNINGS AND ALL INSTRUCTIONS. Failure to follow the warnings and instructions may result in electric shock, fire and/or serious injury. Save all warnings and instructions for future reference. The term "power tool" in the warnings refers to your mains-operated (corded) power tool or battery-operated (cordless) power tool.

WORK AREA SAFETY

- Keep work area clean and well lit. Cluttered or dark areas invite accidents.
- Do not operate power tools in explosive atmospheres, such as in the presence of flammable liquids, gases or dust. Power tools create sparks which may ignite the dust or fumes.
- Keep children and bystanders away while operating a power tool. Distractions can cause you to lose control.

ELECTRICAL SAFETY

- Power tool plugs must match the outlet. Never modify the plug in any way. Do not use any adapter plugs with earthed (grounded) power tools. Unmodified plugs and matching outlets will reduce risk of electric shock.
- Avoid body contact with earthed or grounded surfaces such as pipes, radiators, ranges and refrigerators. There is an increased risk of electric shock if your body is earthed or grounded.
- Do not expose power tools to rain or wet conditions. Water entering a power tool will increase the risk of electric shock.
- Do not abuse the cord. Never use the cord for carrying, pulling or unplugging the power tool. Keep cord away from heat, oil, sharp edges or moving parts. Damaged or entangled cords increase the risk of electric shock.
- When operating a power tool outdoors, use an extension cord suitable for outdoor use. Use of a cord suitable for outdoor use reduces the risk of electric shock.
- If operating a power tool in a damp location is unavoidable, use a ground fault circuit interrupter (GFCI) protected supply. Use of an GFCI reduces the risk of electric shock.

PERSONAL SAFETY

- Stay alert, watch what you are doing and use common sense when operating a power tool. Do not use a power tool while you are tired or under the influence of drugs, alcohol or medication. A moment of inattention while operating power tools may result in serious personal injury.
- Use personal protective equipment. Always wear eye protection. Protective equipment such as dust mask, non-skid safety shoes, hard hat, or hearing protection used for appropriate conditions will reduce personal injuries.
- Prevent unintentional starting. Ensure the switch is in the off-position before connecting to power source and/or battery pack, picking up or carrying the tool. Carrying power tools with your finger on the switch or energising power tools that have the switch on invites accidents.
- Remove any adjusting key or wrench before turning the power tool on. A wrench or a key left attached to a rotating part of the power tool may result in personal injury.

- Do not overreach. Keep proper footing and balance at all times. This enables better control of the power tool in unexpected situations.
- Dress properly. Do not wear loose clothing or jewellery. Keep your hair, clothing and gloves away from moving parts. Loose clothes, jewellery or long hair can be caught in moving parts.
- If devices are provided for the connection of dust extraction and collection facilities, ensure these are connected and properly used. Use of dust collection can reduce dust-related hazards.

POWER TOOL USE AND CARE

- Do not force the power tool. Use the correct power tool for your application. The correct power tool will do the job better and safer at the rate for which it was designed.
- Do not use the power tool if the switch does not turn it on and off. Any power tool that cannot be controlled with the switch is dangerous and must be repaired.
- Disconnect the plug from the power source and/or the battery pack from the power tool before making any adjustments, changing accessories, or storing power tools. Such preventive safety measures reduce the risk of starting the power tool accidentally.
- Store idle power tools out of the reach of children and do not allow persons unfamiliar with the power tool or these instructions to operate the power tool. Power tools are dangerous in the hands of untrained users.
- Maintain power tools. Check for misalignment or binding of moving parts, breakage of parts and any other condition that may affect the power tool's operation. If damaged, have the power tool repaired before use. Many accidents are caused by poorly maintained power tools.
- Keep cutting tools sharp and clean. Properly maintained cutting tools with sharp cutting edges are less likely to bind and are easier to control.
- Use the power tool, accessories and tool bits etc. in accordance with these instructions, taking into account the working conditions and the work to be performed. Use of the power tool for operations different from those intended could result in a hazardous situation.

SERVICE

- Have your power tool serviced by a qualified repair person using only identical replacement parts. This will ensure that the safety of the power tool is maintained.

SPECIFIC SAFETY RULES

- Use auxiliary handle(s), if supplied with the tool. Loss of control can cause personal injury.
- Hold power tool by insulated gripping surfaces, when performing an operation where the cutting accessory may contact hidden wiring or its own cord. Cutting accessory contacting a "live" wire

may make exposed metal parts of the power tool "live" and could give the operator an electric shock.

- **Maintain labels and nameplates.** These carry important information. If unreadable or missing, contact a MILWAUKEE service facility for a free replacement.
- **WARNING** Some dust created by power sanding, sawing, grinding, drilling, and other construction activities contains chemicals known to cause cancer, birth defects or other reproductive harm. Some examples of these chemicals are:

- lead from lead-based paint
 - crystalline silica from bricks and cement and other masonry products, and
 - arsenic and chromium from chemically-treated lumber.
- Your risk from these exposures varies, depending on how often you do this type of work. To reduce your exposure to these chemicals: work in a well ventilated area, and work with approved safety equipment, such as those dust masks that are specially designed to filter out microscopic particles.

SPECIFICATIONS

Cat. No. RAD KIT	Volts AC	No Load RPM	RAD * RPM	33° ** RPM	Capacities							
					Wood					Steel		Masonry
					Flat Boring Bit	Hole Saw	Auger Bit	Ship Auger Bit	Selffeed Bit	Twist Drill	Hole Saw	Carbide-Tipped Bit
1001-1 (3002-1)	120	0-600	lo 0-400 hi 0-900	0-600	1-1/2"	5"	1-1/2"	1-1/2"	3-5/8"	1/2"	3-1/2"	1/2"
					1-1/2"	5"	1-1/2"	1-1/2"	3-5/8"	1/2"	4-1/2"	1/2"
					1-1/2"	4"	1-1/2"	1-1/2"	2-9/16"	1/2"	3"	1/2"
1007-1 (***)	120	0-600	lo 0-400 hi 0-900	0-600	1-1/2"	5"	1-1/2"	1-1/2"	3-5/8"	1/2"	3-1/2"	1/2"
					1-1/2"	5"	1-1/2"	1-1/2"	3-5/8"	1/2"	4-1/2"	1/2"
					1-1/2"	4"	1-1/2"	1-1/2"	2-9/16"	1/2"	3"	1/2"
1101-1 (3102-1)	120	500	lo 0-335 hi 0-750	500	1-1/2"	5"	1-1/2"	1-1/2"	3-5/8"	1/2"	3-3/4"	1/2"
					1-1/2"	6"	1-1/2"	1-1/2"	4-5/8"	1/2"	5"	1/2"
					1-1/2"	4-1/2"	1-1/2"	1-1/2"	2-9/16"	1/2"	3-1/2"	1/2"
1107-1 (3107-1)	120	0-500	lo 0-335 hi 0-750	0-500	1-1/2"	5"	1-1/2"	1-1/2"	3-5/8"	1/2"	3-3/4"	1/2"
					1-1/2"	6"	1-1/2"	1-1/2"	4-5/8"	1/2"	5"	1/2"
					1-1/2"	4-1/2"	1-1/2"	1-1/2"	2-9/16"	1/2"	3-1/2"	1/2"
1107-6 (3107-6)	120	0-500	lo 0-335 hi 0-750	0-500	1-1/2"	5"	1-1/2"	1-1/2"	3-5/8"	1/2"	3-3/4"	1/2"
					1-1/2"	6"	1-1/2"	1-1/2"	4-5/8"	1/2"	5"	1/2"
					1-1/2"	4-1/2"	1-1/2"	1-1/2"	2-9/16"	1/2"	3-1/2"	1/2"
1250-1 (***)	120	0-1000	lo 0-665 hi 0-1500	0-1000	1-1/2"	3-1/8"	1-1/2"	1-1/16"	2-1/4"	1/2"	1-3/4"	1/2"
					--	--	--	--	--	--	--	--
					--	--	--	--	--	--	--	--

* The Right Angle Drill Kit can be purchased with some drills, or as an accessory.
 ** The 33° Angle Drill Kit is available as an accessory only (Cat. No. 48-06-2860).
 *** RAD available as an accessory only (Cat. No. 48-06-2871).

GROUNDING

WARNING Improperly connecting the grounding wire can result in the risk of electric shock. Check with a qualified electrician if you are in doubt as to whether the outlet is properly grounded. Do not modify the plug provided with the tool. Never remove the grounding prong from the plug. Do not use the tool if the cord or plug is damaged. If damaged, have it repaired by a MILWAUKEE service facility before use. If the plug will not fit the outlet, have a proper outlet installed by a qualified electrician.

Grounded Tools: Tools with Three Prong Plugs
 Tools marked "Grounding Required" have a three wire cord and three prong grounding plug. The plug must be connected to a properly grounded outlet (See Figure A). If the tool should electrically malfunction or break down, grounding provides a low resistance path to carry electricity away from the user, reducing the risk of electric shock.

The grounding prong in the plug is connected through the green wire inside the cord to the grounding system in the tool. The green wire in the cord must be the only wire connected to the tool's grounding system and must never be attached to an electrically "live" terminal. Your tool must be plugged into an appropriate outlet, properly installed and grounded in accordance with all codes and ordinances. The plug and outlet should look like those in Figure A.

Fig. A

Double Insulated Tools: Tools with Two Prong Plugs
 Tools marked "Double Insulated" do not require grounding. They have a special double insulation system which satisfies OSHA requirements and complies with the applicable standards of Underwriters Laboratories, Inc., the Canadian Standard Association and the National Electrical Code. Double Insulated tools may be used in either of the 120 volt outlets shown in Figures B and C.

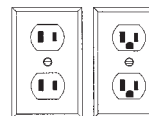
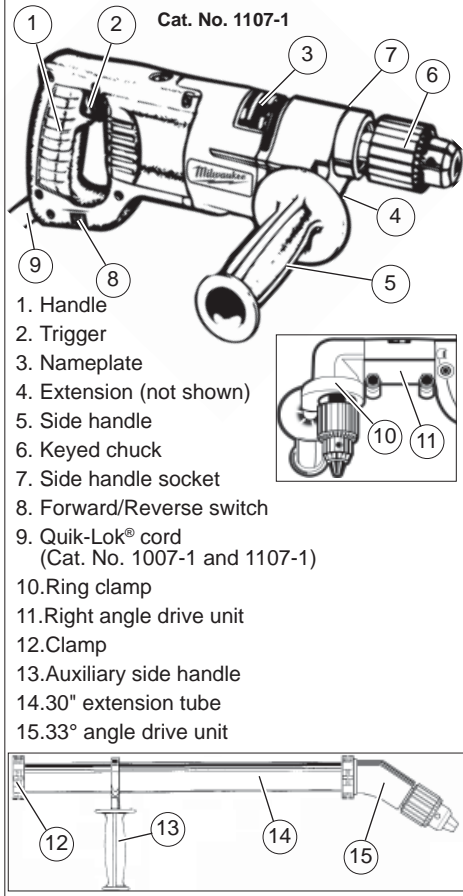
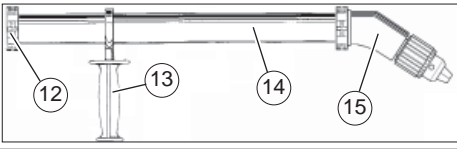

Fig. B Fig. C

FUNCTIONAL DESCRIPTION



- Cat. No. 1107-1
1. Handle
 2. Trigger
 3. Nameplate
 4. Extension (not shown)
 5. Side handle
 6. Keyed chuck
 7. Side handle socket
 8. Forward/Reverse switch
 9. Quik-Lok® cord (Cat. No. 1007-1 and 1107-1)
 10. Ring clamp
 11. Right angle drive unit
 12. Clamp
 13. Auxiliary side handle
 14. 30" extension tube
 15. 33° angle drive unit



SYMBOLOLOGY

A	Amps
V	Volts
~	Alternating Current Only
n₀ XXXXmin.⁻¹	No Load Revolutions per Minute (RPM)
cULus	Underwriters Laboratories, Inc. United States and Canada
NOM-ANCE	Mexican Approvals Marking

EXTENSION CORDS

Grounded tools require a three wire extension cord. Double insulated tools can use either a two or three wire extension cord. As the distance from the supply outlet increases, you must use a heavier gauge extension cord. Using extension cords with inadequately sized wire causes a serious drop in voltage, resulting in loss of power and possible tool damage. Refer to the table shown to determine the required minimum wire size.

The smaller the gauge number of the wire, the greater the capacity of the cord. For example, a 14 gauge cord can carry a higher current than a 16 gauge cord. When using more than one extension cord to make up the total length, be sure each cord contains at least the minimum wire size required. If you are using one extension cord for more than one tool, add the nameplate amperes and use the sum to determine the required minimum wire size.

Guidelines for Using Extension Cords

- If you are using an extension cord outdoors, be sure it is marked with the suffix "W-A" ("W" in Canada) to indicate that it is acceptable for outdoor use.
- Be sure your extension cord is properly wired and in good electrical condition. Always replace a damaged extension cord or have it repaired by a qualified person before using it.
- Protect your extension cords from sharp objects, excessive heat and damp or wet areas.

Nameplate Amperes	Extension Cord Length				
	25'	50'	75'	100'	150'
0 - 2.0	18	18	18	18	16
2.1 - 3.4	18	18	18	18	14
3.5 - 5.0	18	18	16	14	12
5.1 - 7.0	18	16	14	12	12
7.1 - 12.0	16	14	12	10	
12.1 - 16.0	14	12	10		
16.1 - 20.0	12	10			

* Based on limiting the line voltage drop to five volts at 150% of the rated amperes.

READ AND SAVE ALL INSTRUCTIONS FOR FUTURE USE.

ASSEMBLY

WARNING To reduce the risk of injury, always unplug tool before changing or removing accessories. Only use accessories specifically recommended for this tool. Others may be hazardous.

Removing and Replacing Quik-Lok® Cords
MILWAUKEE's exclusive Quik-Lok® Cords provide instant field replacement or substitution.

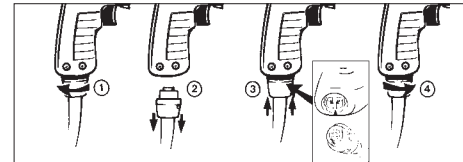

1. To remove the Quik-Lok® Cord, turn the cord nut 1/4 turn to the left and pull it out.
2. To replace the Quik-Lok® Cord, align the connector keyways and push the connector in as far as it will go. Turn the cord nut 1/4 turn to the right to lock.

Installing Side Handle

WARNING To reduce the risk of injury, always use a side handle when using this tool. This tool operates with high torque. Always brace or hold the tool securely.

MILWAUKEE D-Handle Drills are supplied with a side handle that can be installed on either side of the tool for right or left handed use. To install the side handle, attach the side handle to the extension. Thread it into the socket on the desired side of the tool and tighten it securely. Because of the high torque of this drill, the side handle must always be used when operating the drill.

WARNING When using the D-handle drill without the right angle drive unit, do not clamp the ring clamp with attached side handle to the front of the gear case; thread the side handle onto the tool instead. Do not use the extension when using the ring clamp.

Ring Clamp, Extension, and Side Handle for Right Angle Drive Unit

For D-handle drill with Right Angle Drive Unit:
A ring clamp, extension, and side handle are supplied with the Right Angle Drive Unit. When using a right angle drive unit, attach the side handle to the ring clamp. Do not use the extension when using the ring clamp. The ring clamp with attached side handle clamps onto the right angle drive unit and can swivel 360° and locked tight in any position.

For D-handle drill without Right Angle Drive Unit:
When using the D-handle drill without the right angle drive unit, remove the ring clamp with attached side handle, then remove the side handle from the ring clamp. Attach the side handle to the extension. The side handle can be installed on either side of the tool for right or left handed use. To install the extension with attached side handle, thread it into the socket on the desired side of the tool (for right or left-handed use) and tighten securely.
NOTE: If you have an extra ring clamp with attached side handle and extension with attached side handle, do not use the extension with attached side handle when using the right angle drive unit. Remove it from the tool.

WARNING To prevent personal injury, always remove the chuck key from the chuck after each use.

Installing Bits into Keyed Chucks

Be sure that the shank of the bit and the chuck jaws are clean. Dirt particles may cause the bit to line up improperly. Do not use bits larger than the maximum recommended capacity of the drill because gear damage or motor overloading may result. For best performance, be sure that the bits are properly sharpened before use.

1. Unplug the tool.
2. Open the chuck jaws wide enough to insert a bit. Allow the bit to strike the bottom of the chuck. Center the bit in the chuck jaws and tighten the jaws by hand to align the bit.
3. Place the chuck key into each of the three holes in the chuck, turning it clockwise to tighten the chuck securely.
NOTE: Never use a wrench or means other than a chuck key to tighten or loosen the chuck.
4. To remove the bit, insert the chuck key into one of the holes in the chuck and turn it counterclockwise.

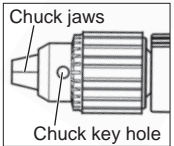

Removing the Chuck from the Drill

1. To remove the left-hand screw inside the chuck, unplug the tool and open the chuck jaws. Insert a T-handle hex key into the screw inside the chuck. Turn the T-handle hex key and remove the screw. Save the screw for installing your new chuck.
2. To remove chuck; tighten a large hex key into the chuck. Place the chuck on a workbench as shown. Strike the hex key with a soft-headed mallet to loosen the chuck. Remove the chuck by hand.

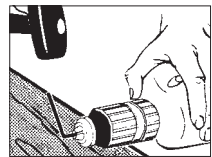

Installing 30" Extension Tube

- The 30" extension tube **MUST** be used when attaching the 33° Angle Drive. The extension tube can optionally be used with the Right Angle Drive.
1. Remove the chuck from the drill (see "Removing the Chuck From the Drill").
 2. Slide extension tube over drill collar and tighten clamp securely.
 3. Slide auxiliary side handle onto 30" extension tube and secure.
 4. Insert drive shaft through 30" extension tube.
 5. Engage hex nut with hex drive on drill.

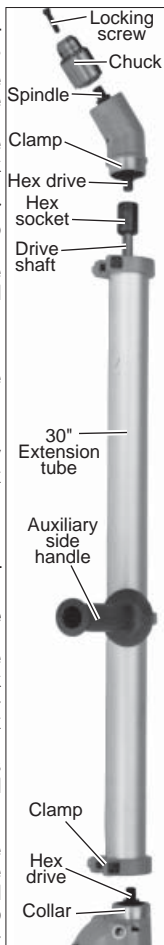

Attaching 33° Angle Drive

1. Attach 33° angle drive by inserting hex drive into hex socket in extension drive shaft. Secure with clamp.
2. Thread the chuck onto the 33° angle drive spindle. **INSTALL CHUCK LOCKING SCREW.**

Attaching Right Angle Drive to Drill

1. Remove the chuck from the drill (see "Removing the Chuck From the Drill"). Slip the double hex coupling over the hex on the drill spindle. Loosen the clamping screws on the clamping sleeve and slip the sleeve onto the drill collar.
2. Slide the Right Angle Drive head into the other side of the sleeve and turn the drive head slightly in either direction so the hexagonal hole in the coupling engages the hexagonal portion of the spindle.

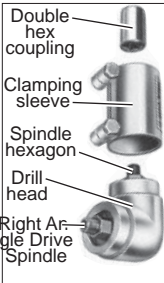

- NOTE:** Attaching the drill chuck to the side marked "LOW" reduces the speed by 1/3, or 33%. Attaching the drill chuck to the opposite side increases the speed by 50%.
3. When assembled, turn the Right Angle Drive head to the desired position and tighten the clamping screws to secure the unit. Thread the chuck onto the Right Angle Drive spindle. **INSTALL CHUCK LOCKING SCREW.**

Attaching Right Angle Drive to 30" Extension

1. Attach right angle drive by inserting spindle hexagon into hex socket in extension drive shaft. Secure with clamp.
2. Thread the chuck onto the right angle drive spindle. **INSTALL CHUCK LOCKING SCREW.**

Removing Chuck From Angle Drive Units

The chuck can be removed from the angle drive unit in the same manner it is removed from the drill; however, **ALWAYS REMOVE ANGLE DRIVE FROM THE DRILL BEFORE ATTEMPTING TO LOOSEN THE CHUCK.**

This will prevent damaging the drill's gearing. Use the open end wrench provided to hold the angle drive spindle before attempting to loosen the chuck.



OPERATION

WARNING To reduce the risk of injury, always unplug tool before attaching or removing accessories or making adjustments. Use only specifically recommended accessories. Others may be hazardous.

WARNING To reduce the risk of injury, wear safety goggles or glasses with side shields.

Using Forward/Reverse Switch

1. For **forward** (clockwise) rotation, push the forward/reverse switch to FWD as shown. Check the direction of rotation before use.
2. For **reverse** (counterclockwise) rotation, push the forward/reverse switch to REV as shown. Check the direction of rotation before use. Although an interlock prevents reversing the tool while the motor is running, allow the motor to come to a full stop before reversing.



WARNING To reduce the risk of injury, keep hands and cord away from the bit and all moving parts.

Starting, Stopping and Controlling Speed

1. To **start** the tool, pull trigger.
2. To **stop** the tool, release the trigger.
3. To vary the speed, increase or decrease pressure to the trigger. The further the trigger is pulled, the greater the speed.

WARNING To reduce the risk of explosion, electric shock and property damage, always check the work area for hidden pipes and wires before drilling.

Drilling

1. Before drilling, be sure the workpiece is clamped securely. Use backing material to prevent damage to the workpiece during breakthrough.
2. When starting a hole, place the drill bit on the work surface and apply firm pressure. Begin drilling at a slow speed, gradually increasing the speed as you drill.
3. Always apply pressure in line with the bit. Use enough pressure to keep the drill biting, but do not push hard enough to stall the motor.
4. Reduce pressure and ease the bit through the last part of the hole. While the tool is still running, pull the bit out of the hole to prevent jamming.

Stalling

If the tool seems as if it is about to stall, maintain a firm grip and reduce pressure slightly to allow the bit to regain speed. If the tool does stall, release the trigger immediately. Reverse the motor, remove the bit from the work and start again. Do not pull the trigger on and off in an attempt to start a stalled drill. This can damage the drill.

WARNING To reduce the risk of personal injury, hold the tool securely. Brace tools with side handles as shown (Fig. 1, 2 & 3). If the bit binds, the tool will be forced in the opposite direction. Bits may bind if they are misaligned or when breaking through a hole. Wood boring bits can also bind if they run into nails or knots.

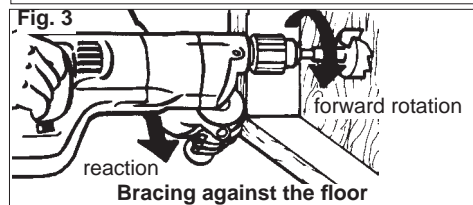
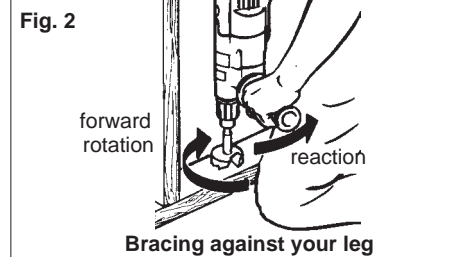
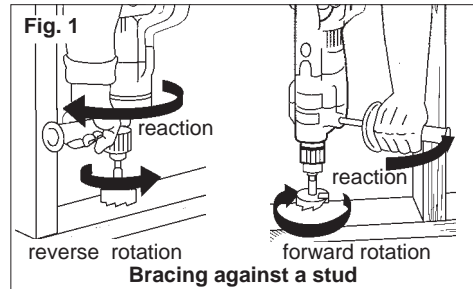

APPLICATIONS

Selecting Bits

When selecting a bit, use the right type for your job. For best performance, always use sharp bits.

Drilling in Wood, Composition Materials and Plastic

When drilling in wood, composition materials and plastic, start the drill slowly, gradually increasing speed as you drill. Use low speeds for plastics with a low melting point.

NOTE: Keep the speed low enough to prevent burning the bit.

Drilling in Metal

When drilling in metal, use high speed steel twist drills or hole saws. Use a center punch to start the hole. Lubricate drill bits with cutting oil when drilling in iron or steel. Use a coolant when drilling in non-ferrous metals such as copper, brass or aluminum. Back the material to prevent binding and distortion on breakthrough.

Drilling in Masonry

When drilling in masonry, use high speed carbide-tipped bits. Drilling soft masonry materials such as cinder block requires little pressure. Hard materials like concrete require more pressure. A smooth, even flow of dust indicates the proper drilling rate. Do not let the bit spin in the hole without cutting. Do not use water to settle dust or to cool bit. Do not attempt to drill through steel reinforcing rods. Both actions will damage the carbide.

ACCESSORIES



WARNING To reduce the risk of injury, always unplug the tool before attaching or removing accessories. Use only specifically recommended accessories. Others may be hazardous.

MAINTENANCE



WARNING To reduce the risk of injury, always unplug your tool before performing any maintenance. Never disassemble the tool or try to do any rewiring on the tool's electrical system. Contact a **MILWAUKEE** service facility for ALL repairs.

Maintaining Tools

Keep your tool in good repair by adopting a regular maintenance program. Before use, examine the general condition of your tool. Inspect guards, switches, tool cord set and extension cord for damage. Check for loose screws, misalignment, binding of moving parts, improper mounting, broken parts and any other condition that may affect its safe operation. If abnormal noise or vibration occurs, turn the tool off immediately and have the problem corrected before further use. Do not use a damaged tool. Tag damaged tools "DO NOT USE" until repaired (see "Repairs").

Under normal conditions, relubrication is not necessary until the motor brushes need to be replaced. After six months to one year, depending on use, return your tool to the nearest **MILWAUKEE** service facility for the following:

- Lubrication
- Brush inspection and replacement
- Mechanical inspection and cleaning (gears, spindles, bearings, housing, etc.)
- Electrical inspection (switch, cord, armature, etc.)
- Testing to assure proper mechanical and electrical operation



WARNING To reduce the risk of injury, electric shock and damage to the tool, never immerse your tool in liquid or allow a liquid to flow inside the tool.

Cleaning

Clean dust and debris from vents. Keep the tool handles clean, dry and free of oil or grease. Use only mild soap and a damp cloth to clean your tool since certain cleaning agents and solvents are harmful to plastics and other insulated parts. Some of these include: gasoline, turpentine, lacquer thinner, paint thinner, chlorinated cleaning solvents, ammonia and household detergents containing ammonia. Never use flammable or combustible solvents around tools.

Repairs

If your tool is damaged, return the entire tool to the nearest service center.

READ AND KEEP THIS FOR FUTURE REFERENCE



**CARE
AND
OPERATING
INSTRUCTIONS**

**HEAVY-DUTY
HOLE-SHOOTERS**

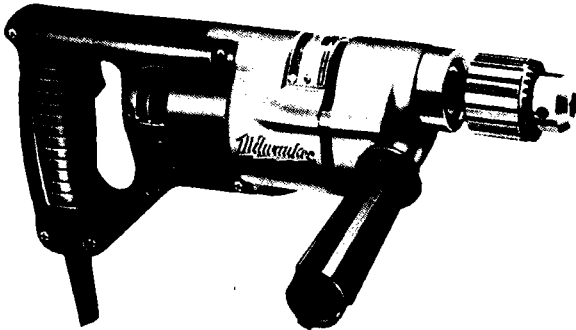

D-HANDLE HOLE-SHOOTERS

CAT. NO.	CAT. NO.
0801	1101
0871	1101-1 Rev.
1001	1101-3 Rev. (240V)
1001-1 Rev.	1201-1 Rev.
	1250-1 Rev.

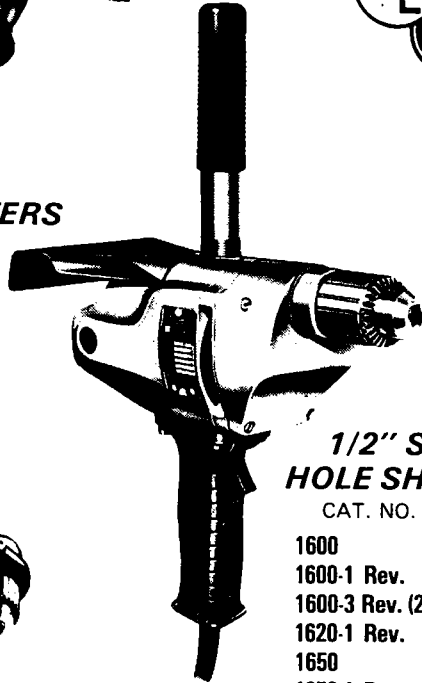

**1/2" SUPER
HOLE SHOOTERS**

CAT. NO.

- 1600
- 1600-1 Rev.
- 1600-3 Rev. (240V)
- 1620-1 Rev.
- 1650
- 1650-1 Rev.
- 1650-3 Rev. (240V)

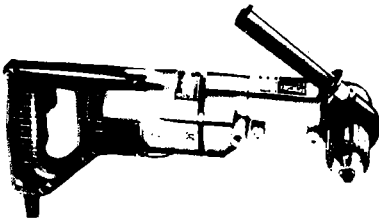

**RIGHT ANGLE DRIVE UNITS
AND RIGHT ANGLE DRILL KITS**

Powered by D-Handle Drills Listed Above

IMPORTANT—Before placing tool in operation, record the following information from nameplate.

THIS SYMBOL ...



... IS YOUR ASSURANCE

1. That every tool manufactured by MILWAUKEE is produced in accordance with applicable Standards for Safety of Underwriters' Laboratories and American National Standards (ANSI).
2. That compliance with applicable safety standards is assured by independent inspection and testing conducted by Underwriters' Laboratories (UL).
3. That every motorized tool manufactured by MILWAUKEE is fully inspected.
4. That every tool has with it adequate instructions and a list of safety rules for the protection of the user.

WARNING: When using electric tools, basic safety precautions should always be followed to reduce the risk of fire, electric shock and personal injury including the following items. Read all instructions and save them for future reference.

SAFETY INSTRUCTIONS FOR ALL POWER TOOLS

1. **KNOW YOUR POWER TOOL.** Read owner's manual carefully. Learn its applications and limitations as well as the specific potential hazards peculiar to this tool.
2. **GROUND ALL TOOLS—UNLESS DOUBLE-INSULATED.** If the tool is equipped with a three prong plug, it should be plugged into a three hole electrical receptacle. If an adapter is used to accommodate a two hole receptacle, the grounding ear must be attached to a known ground. Never remove the third prong.
3. **KEEP GUARDS IN PLACE** and in working order.
4. **KEEP WORK AREA CLEAN.** Cluttered areas and benches invite accidents.
5. **AVOID DANGEROUS ENVIRONMENTS.** Don't expose power tools to rain or use in damp or wet locations. Do not use tool in presence of flammable liquids or gases. Keep the work area well lit.
6. **KEEP CHILDREN AWAY.** All visitors should be kept a safe distance from the work area. Do not let visitors contact tool or extension cords.
7. **STORE IDLE TOOLS.** When not in use, tools should be stored in a dry, high or locked-up place—out of reach of children.
8. **DON'T FORCE TOOL.** It will do the job better and safer at the rate for which it was designed.
9. **USE RIGHT TOOL.** Don't force a small tool or attachment to do the job of a heavy-duty tool. Don't use a tool for a purpose it was not designed for, such as using a circular saw for cutting tree limbs or logs.
10. **WEAR PROPER APPAREL.** No loose clothing or jewelry to get caught in moving parts. Rubber gloves and insulated non-skid footwear are recommended when working outdoors. Wear protective covering to contain long hair.
11. **USE SAFETY GLASSES** at all times. Also, use a face or dust mask if cutting operation is dusty.
12. **DON'T ABUSE CORD.** Never carry the tool by its cord or yank it to disconnect from the receptacle. Keep cord from heat, oil and sharp edges.
13. **SECURE WORK.** Use clamps or a vise to hold work. It's safer than using your hand and it frees both hands to operate tool.
14. **DON'T OVERREACH.** Keep proper footing and balance at all times.
15. **DISCONNECT TOOLS.** When not in use; before servicing; when changing accessories such as blades, bits, cutters, etc.
16. **GUARD AGAINST ELECTRIC SHOCK.** Prevent body contact with grounded surfaces such as pipes, radiators, ranges and refrigerator enclosures.
17. **REMOVE ADJUSTING KEYS AND WRENCHES.** Form a habit of checking to see that keys and adjusting wrenches are removed from tool before turning it on.

18. **MAINTAIN TOOLS WITH CARE.** Keep tools sharp and clean at all times for best and safest performance. Follow instructions for lubricating and changing accessories. Keep handles dry, clean and free of oil or grease. Inspect switches, tool cords and extension cords periodically and have them repaired or replaced by an authorized service facility if damaged. Check moving parts for alignment and binding as well as for breakage and improper mounting. Damaged parts should be repaired or replaced by an authorized service facility unless otherwise indicated in this instruction book. CAUTION: Do not use carbon tetrachloride.
19. **AVOID ACCIDENTAL STARTING.** Don't carry a plugged-in tool with your finger on the switch. Be sure the switch is turned off before plugging in a tool. Do not use a tool if the switch does not turn it on or off.
20. **WEAR EAR PROTECTORS** when using for extended periods.
21. **ACCESSORIES.** The use of any accessories other than what is listed or recommended for this particular tool may be hazardous.
22. **KEEP HANDS AWAY FROM CUTTING EDGES AND ALL MOVING PARTS.**
23. **USE INSULATED SURFACES.** A double-insulated or grounded tool may be made live if the blade or bit comes in contact with live wiring in a wall, floor, ceiling, etc. Always check the work area for live wires and hold the tool by the insulated surfaces when making "blind" or plunge cuts.
24. **GRINDING WHEELS.** Use only grinding wheels with "Safe Speed" at least as high as the no load RPM" marked on the nameplate.
25. **USE SIDE HANDLES** when supplied with tool for control and safety.
26. **STAY ALERT.** Watch what you are doing and use common sense. Do not operate tool when you are tired.

GROUNDING INSTRUCTIONS

This tool should be grounded while in use to protect the user from electric shock. The tool is equipped with an approved three conductor cord and three prong grounding-type plug to fit the proper grounding-type receptacle. The green conductor in the cord is the grounding wire. Never connect the green wire to a live terminal. If your unit is for use on less than 150 volts, it has a plug that looks like figure "A". If it is for use on 150 to 250 volts, it has a plug that looks like figure "C".

NOTE

The use of three-prong adapters in Canada is prohibited by the Canadian Electrical Code.

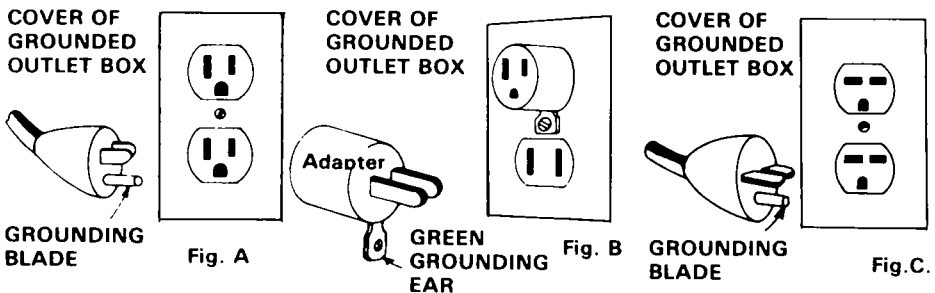

An adapter, Figure "B", is available for connecting Figure "A" type plugs to two prong receptacles. The green grounding ear or wire extending from the adapter must be connected to a permanent ground such as a properly grounded outlet box. No adapter is available for Figure "C" type plugs.

NOTE: THE RECEPTACLE MUST BE GROUNDED FOR SAFE USE OF ADAPTER; IF IN DOUBT, CALL A QUALIFIED ELECTRICIAN AND HAVE THE RECEPTACLE CHECKED FOR GROUND.

EXTENSION CORD CHART

When an extension cord is used, it should be a three wire cord to permit proper grounding of the tool. As the distance from the supply outlet increases, heavier gauge extensions are required. The use of extension cords of inadequate size wire causes a serious drop in voltage, loss of power and possible motor damage. This table is based on limiting the line voltage drop to five volts at 150% of rated amperes.

Ampere rating (on Nameplate)	0- 2.00	2.10- 3.4	3.5- 5.00	5.10- 7.0	7.10- 12.0	12.1- 16.0	16.1- 20.0	
Ext. Cable Length	Wire Size							
25 Ft.	18	18	18	18	16	14	12	Not normally available as flexible extension cord.
50 Ft.	18	18	18	16	14	12	10	
75 Ft.	18	18	16	14	12	10	8	
100 Ft.	18	16	14	12	10	8	8	
150 Ft.	16	14	12	12	8	8	6	
200 Ft.	16	14	12	10	8	6	4	
300 Ft.	14	12	10	8	6	4	4	
400 Ft.	12	10	8	6	4	4	2	
500 Ft.	12	10	8	6	4	2	2	
600 Ft.	10	8	6	4	2	2	1	
800 Ft.	10	8	6	4	2	1	0	
1000 Ft.	8	6	4	2	1	0	0	

IF USING AN EXTENSION CORD OUTDOORS, BE SURE IT IS MARKED WITH THE SUFFIX "W-A" ("W" IN CANADA) TO INDICATE THAT IT IS ACCEPTABLE FOR OUTDOOR USE.

CAUTION: Applications which could cause this tool to be driven at speeds more than 25% in excess of its rated speed are potentially dangerous and constitute misuse. This includes the use of voltage boosters. To prevent personal injury and damage to the tool, do not use this tool to start or drive small engines or other rotating machinery unless specifically recommended in this manual. The Milwaukee Electric Tool Corporation assumes no responsibility for damage or accidents resulting from the misuse of this tool, its misapplication or nonadherence to precautionary safety measures.

Read All Instructions And Save Them For Future Reference

TO INSERT DRILL BITS

These MILWAUKEE Hole-Shooters are equipped with industrial, key type, geared chucks. When inserting bit, open chuck jaws wide enough to allow the bit to strike the bottom of the chuck. Be sure the shank of the bit and the chuck jaws are clean. Dirt particles may cause the bit to line up improperly. Tighten jaws by hand to align bit before tightening with chuck key. Never use a wrench or means other than the chuck key to tighten or loosen the chuck. Do not use bits which are larger than the rated capacity of the Drill. Gear damage or motor overload may result. For maximum drilling performance, be sure bits are properly sharpened before using.

OPERATION

Before drilling, clamp material down securely. A poorly secured piece of material may result in inaccurate drilling or personal injury if the bit should bind. When drilling holes in light gauge metal or wood, back up the material with a wooden block to prevent bending, distorting or splintering.

Mark the center of the hole to be drilled with a center punch to give the bit a start and to prevent it from "wandering". Place the drill on the center mark while in the "off" position. Holding the drill firmly at a 90° angle to the work, start motor and apply steady pressure. Do not use the trigger switch lock button in situations where the bit may bind making it necessary to stop the drill suddenly. Lubricate the drill with cutting oil when drilling iron or steel. Use a coolant when drilling non-ferrous metals such as copper, brass or aluminum.

REVERSING MOTORS

Hole-Shooter Models . . . 1001-1, 1101-1, 1201-1, 1250-1, 1600-1, 1600-3, 1620-1, 1650-1 and 1650-3 are equipped with reversing motors. Allow motor to come to a complete stop before reversing. Reversing with motor and gears in motion may cause serious damage.

AUXILIARY SIDE HANDLE

An Auxiliary Side Handle which screws into either side of the gear case is furnished with Hole-Shooter Models 0801 thru 1250-1. An additional handle is furnished with Right Angle Drive kits which clamps on the Bearing Cap of the Right Angle Drive Unit. When using Right Angle Drive do not use Hole-Shooter side handle on gear case. Models 1600 thru 1650-3 are furnished with an auxiliary Pipe Handle which screws into the motor housing. Always use Side Handle or Pipe Handle to maintain safe control.

MAINTENANCE

All servicing other than recommended in this instruction manual must be done by a MILWAUKEE Service Center or Authorized Service Station.

CHUCK REMOVAL

Non-Reversing Drills To remove the chuck from MILWAUKEE Hole-Shooters with non-reversing motors, hold the tool so that **only** the chuck rests firmly and squarely on the edge of a solid bench. Insert the chuck key or a chuck remover bar in a keyhole of the chuck. Turn the chuck until the key is at about a 30° angle to the bench top and strike the key sharply with a hammer so the chuck turns in the direction the chuck turns when operated in a forward position. This should free the chuck from the threaded spindle (right hand thread) and you will be able to remove it by hand.

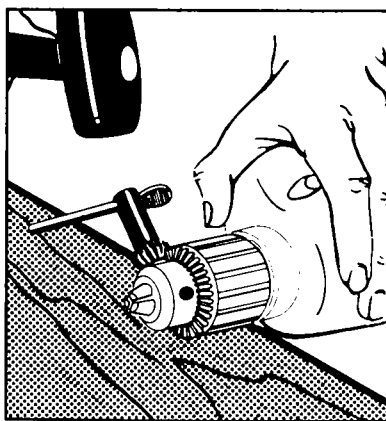

Reversing Drills To remove the chuck from MILWAUKEE Hole-Shooters, open the jaws of the chuck as far as possible and turn out the left hand thread socket head screw. This screw locks the chuck to the spindle. Once screw has been removed, the chuck may be taken off as described in the above copy for Non-Reversing Drills.

LUBRICATON

All MILWAUKEE Hole-Shooters are lubricated at the factory and require additional lubricaton only at intervals of 6 months to 1 year depending upon the amount of use. When further lubrication is necessary, care should be taken to prevent the armature from coming loose when the gear case is removed. To remove gear case, remove the screws from the front of the case. Holding the tool on the diaphragm, lightly tap the gear case to loosen it. If the gear case will not completely dislodge, set the complete tool on a workbench and use two screwdrivers opposite each other to gently pry it off. If the diaphragm pulls free of the motor housing, the armature may be pulled out of the back bearing, possibly permitting the brushes to slip off the commutator. Should this occur, return the entire tool to the nearest Authorized MILWAUKEE Service Center or Authorized Service Station for reassembly. Return all parts.

Repack 2/3 full with MILWAUKEE Type "A" grease. 1/2 lb. Can, Cat. No. 49-08-0500. 1 lb. Can, Cat. No. 49-08-0800.

BRUSHES AND COMMUTATOR

Failure of the motor to start or to operate efficiently can usually be attributed to worn or damaged brushes, brushes sticking in the holders and failing to make proper contact with the commutator, or to the commutator being dirty or rough. Frequent inspection of brushes and commutator is recommended.

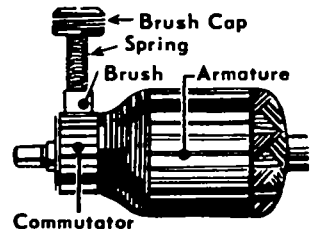

To inspect the brushes, remove plug from power source. Unscrew brush retainer caps located on motor housing. Pull out brush retainer springs and brushes.

Replace brushes when worn down to 1/4". Always replace both brushes at the same time. When inspecting brushes, also check the commutator for wear. If worn badly, send the complete tool to a MILWAUKEE Service Center or Authorized Service Station for undercutting and dressing of the commutator.

INSTRUCTIONS COVERING RIGHT ANGLE DRIVES

NO. 48-06-2871 REVERSING AND NO. 48-06-2870 NON-REVERSING

USED WITH "D" HANDLE DRILLS ILLUSTRATED ON FRONT COVER

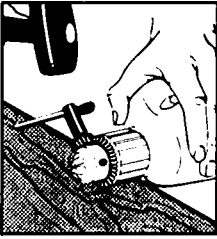

REST CHUCK ON SOLID SURFACE BEFORE REMOVING.
FAILURE TO DO SO MAY RESULT IN A BENT SPINDLE.

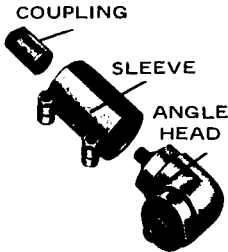

When removing chuck from reversing drills it is necessary to first remove the (l.h.) threaded socket screw as per instructions outlined in paragraph 5 on page 5 of this booklet.

To remove chuck from your drill for use with non-reversing "RAD" follow instructions outlined in paragraph 4 on page 5 of this booklet.

ATTACHING RIGHT ANGLE DRIVE TO DRILL

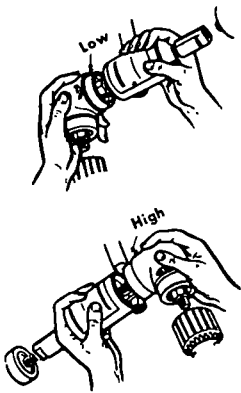

After removing chuck from drill, the double hex coupling should be slipped over the hex on the drill spindle. After mounting coupling, loosen the clamping screws on the clamping sleeve and slip the sleeve on to the collar of the drill. Slide Right Angle Drill head into the other end of the sleeve and turn the drive head slightly in either direction so the hexagon hole in the coupling engages the hexagon portion of the spindle. Attaching the drill chuck to the side designated "low" reduces the speed by 1/3 and increases torque 50%. Attaching the chuck to the opposite spindle increases the speed by 50%. When assembled, turn the Right Angle head to the desired position and tighten the clamping screws to secure the unit. Thread drill chuck on Right Angle spindle. **INSTALL CHUCK LOCKING SCREW ON REVERSING MODELS.**

REMOVING CHUCK FROM "RAD" UNIT



Chuck can be removed from Right Angle Drive in the same manner it was removed from your drill; however, **ALWAYS REMOVE RIGHT ANGLE DRIVE FROM THE DRILL BEFORE ATTEMPTING TO LOOSEN CHUCK.** This will prevent damaging drills gearing. Use the open end wrench provided to hold Right Angle Drive Spindle before attempting to loosen chuck.

HEAVY-DUTY TOOLS FOR CONTRACTORS AND INDUSTRY

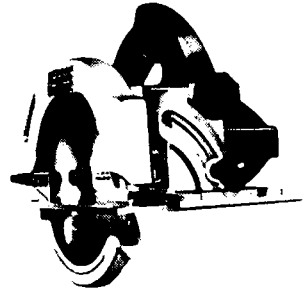
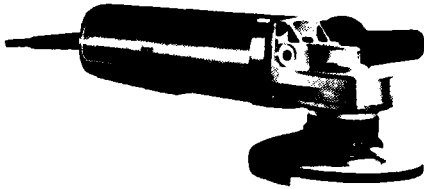

Milwaukee
Amstar

WARRANTY

Every MILWAUKEE Tool is thoroughly inspected and tested before leaving the factory. Should any trouble develop, return the complete tool prepaid to the Factory, Branch or nearest Authorized Service Station. If inspection shows the trouble is caused by defective workmanship or material, all repairs will be made without charge and the tool will be returned transportation prepaid.

This warranty does not apply where: (1) repairs or attempted repairs have been made by persons other than Factory, Branch or Authorized Service Station personnel; (2) repairs are required because of normal wear; (3) the tool has been misused or involved in an accident; (4) misuse is evident such as caused by overloading the tool beyond its rated capacity; (5) the tool has been used after partial failure or (6) the tool has been used with an improper accessory. No other warranty written or verbal, is authorized.

