



SERVICE PARTS LIST

BULLETIN NO.
54-05-0285

SPECIFY CATALOG NO. AND SERIAL NO. WHEN ORDERING PARTS		REVISED BULLETIN	DATE
M18™ FUEL™ Spot Clean Up Vacuum			Sept. 2020
CATALOG NO.	0940-20	STARTING SERIAL NO.	L51A
			WIRING INSTRUCTION See page two

EXAMPLE:

00	0
----	---

 Component Parts (Small #) Are Included
 When Ordering The Assembly (Large #).

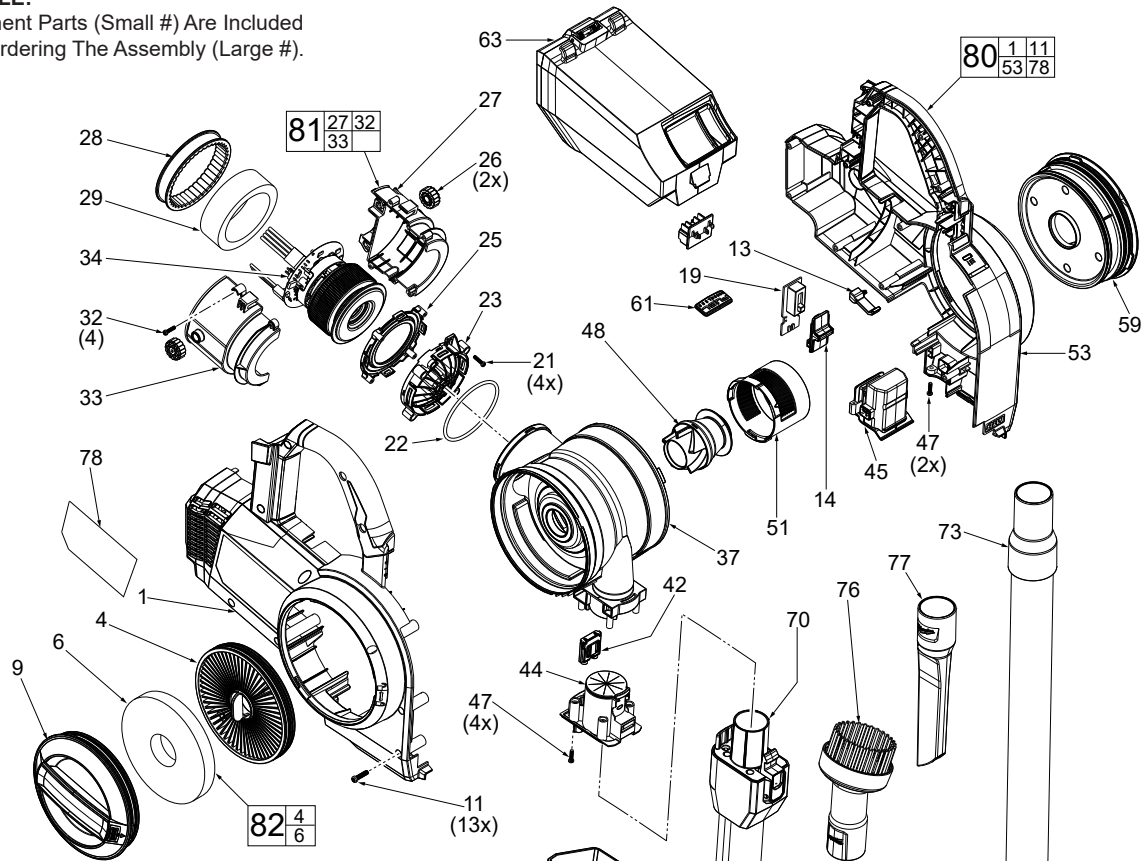
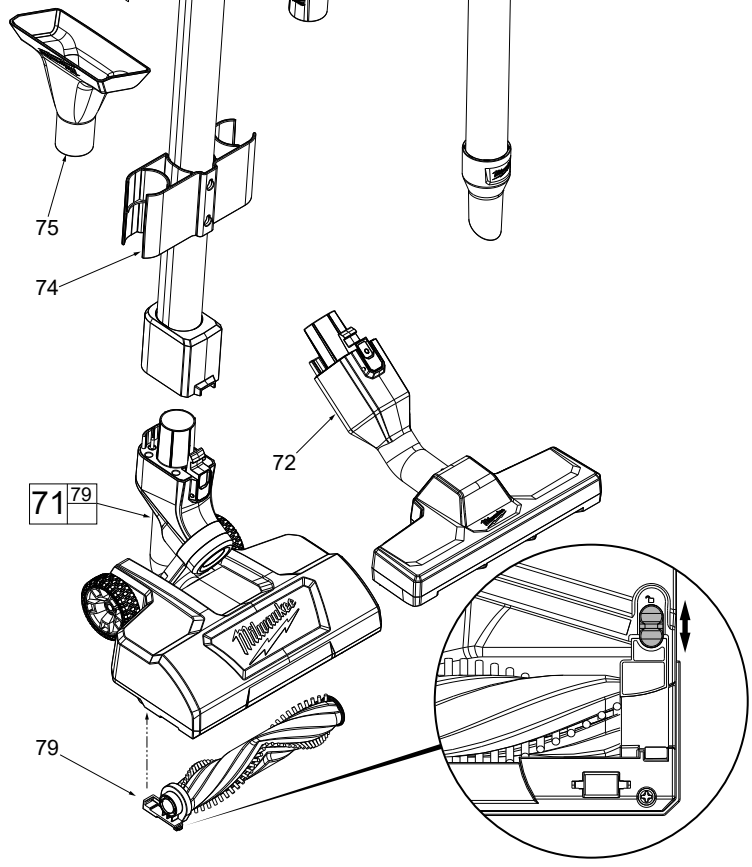

FIG.	PART NO.	DESCRIPTION OF PART	NO. REQ.
1	31-50-0088	Main Housing Halve-Right	(1)
4	43-31-0011	Filter Assembly	(1)
6	43-31-0013	Foam Filter	(1)
9	31-15-0111	Main Housing Cover Assembly-Right	(1)
11	06-82-0212	M4 x 16mm Pan Hd. ST Screw	(13)
13	23-26-0035	Light Guide	(1)
14	42-42-0076	Two Speed On-Off Push Button	(1)
19	23-66-0301	Switch PCBA	(1)
21	06-82-0213	M3 x 12mm Pan Hd. ST Screw	(4)
22	34-40-0247	O-Ring	(1)
23	31-15-0125	Motor Housing Front Cover	(1)
25	44-66-0153	Motor Seal Cover Plate	(1)
26	42-76-0071	Motor Sleeve	(2)
27	23-14-0030	Motor Insulator-Left	(1)
28	44-52-0086	Motor Housing Shock Pad	(1)
29	43-31-0021	Soundproof Foam Filter	(1)
32	06-82-0246	M3 x 12mm Pan Hd ST Screw	(4)
33	23-14-0032	Motor Insulator-Right	(1)
34	14-20-0186	Electronics Assembly	(1)
37	42-92-0088	Cyclone Inner Hood	(1)
42	23-33-0016	Socket Assembly	(1)
44	44-14-0076	Inlet Connector Assembly	(1)
45	42-28-0036	Button Fixing Block	(1)
47	06-82-0236	M3 x 12mm Pan Hd. ST Screw	(6)
48	43-81-0077	Impeller	(1)
51	31-44-0318	Cyclone Housing Assembly	(1)
53	31-44-0256	Main Housing Halve-Left	(1)
59	31-15-0211	Main Housing Cover Assembly-Left	(1)
61	43-84-0024	'FUEL' Brushless Plate	(1)
63	42-51-0022	Debris Tank Assembly	(1)
70	45-86-0068	Wand	(1)
71	31-01-0101	Power Floor Tool	(1)
72	31-01-0102	Non-Powered Floor Tool	(1)
73	14-37-0109	Hose	(1)
74	31-01-0103	Accessory Holder	(1)
75	31-01-0104	Utility Tool	(1)
76	49-90-2017	Round Brush Tool	(1)
77	31-01-0865	Crevice Tool	(1)
78	12-20-0283	Service Nameplate	(1)
79	31-01-0106	Beater Bar	(1)
80	31-44-0289	Main Housing Service Kit	(1)
81	23-16-0177	Motor Insulator Kit	(1)
82	49-90-2012	Replacement Filter Assembly	(1)





- As an aid to reassembly, take notice of wire routings and position in wire guides and traps while dismantling tool.
- Route wires into wire traps and channels as shown.
- Be sure to place wires down into wire traps, being sure to remove any wire slack while routing.
- Be sure all components of electronics assembly are seated firmly and squarely in the corresponding cavity of handle support.
- Be sure there are no interferences when installing handle cover over handle support. Watch for pinched wires.
- Check for proper functionality of slide buttons and switch prior to installing battery.

Learn more about wet and dry vacuums we have.