

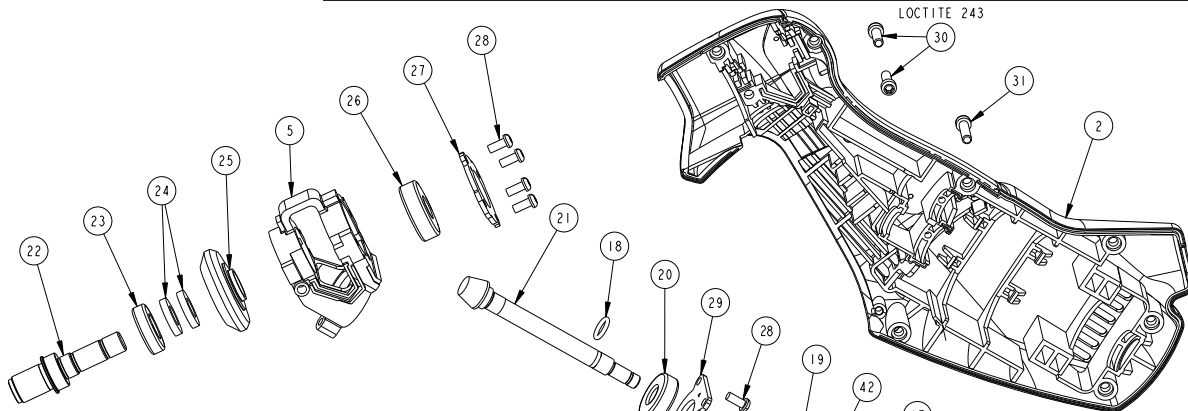

# SERVICE PARTS LIST

BULLETIN NO.  
54-06-0373

SPECIFY CATALOG NO. AND SERIAL NO. WHEN ORDERING PARTS		REVISED BULLETIN 54-06-0372
<b>CLOSE QUARTERS DRILL</b>		
CATALOG NO. <b>0370-20</b>	STARTING SERIAL NO. <b>B11B</b>	WIRING INSTRUCTION <b>58-01-2372</b>



Place 1/2 oz. (14 gm) of \*Type 'Z' Grease, No 49-08-7655, into gear area of Bevel Gear Box [5].

Place 1/2 oz. (14 gm) total of \*Type 'Z' Grease, No. 49-08-7655, into Helical Gear pocket of handle halves [1,2].

**\*NOTE:**  
'Z' Grease (yellow in color) is not compatible with original grease (Green in color). Remove all original Green grease prior to using Type 'Z'.

**\*NOTE:**  
'Z' Grease (yellow in color) is not compatible with original grease (Green in color). Remove all original Green grease prior to using Type 'Z'.

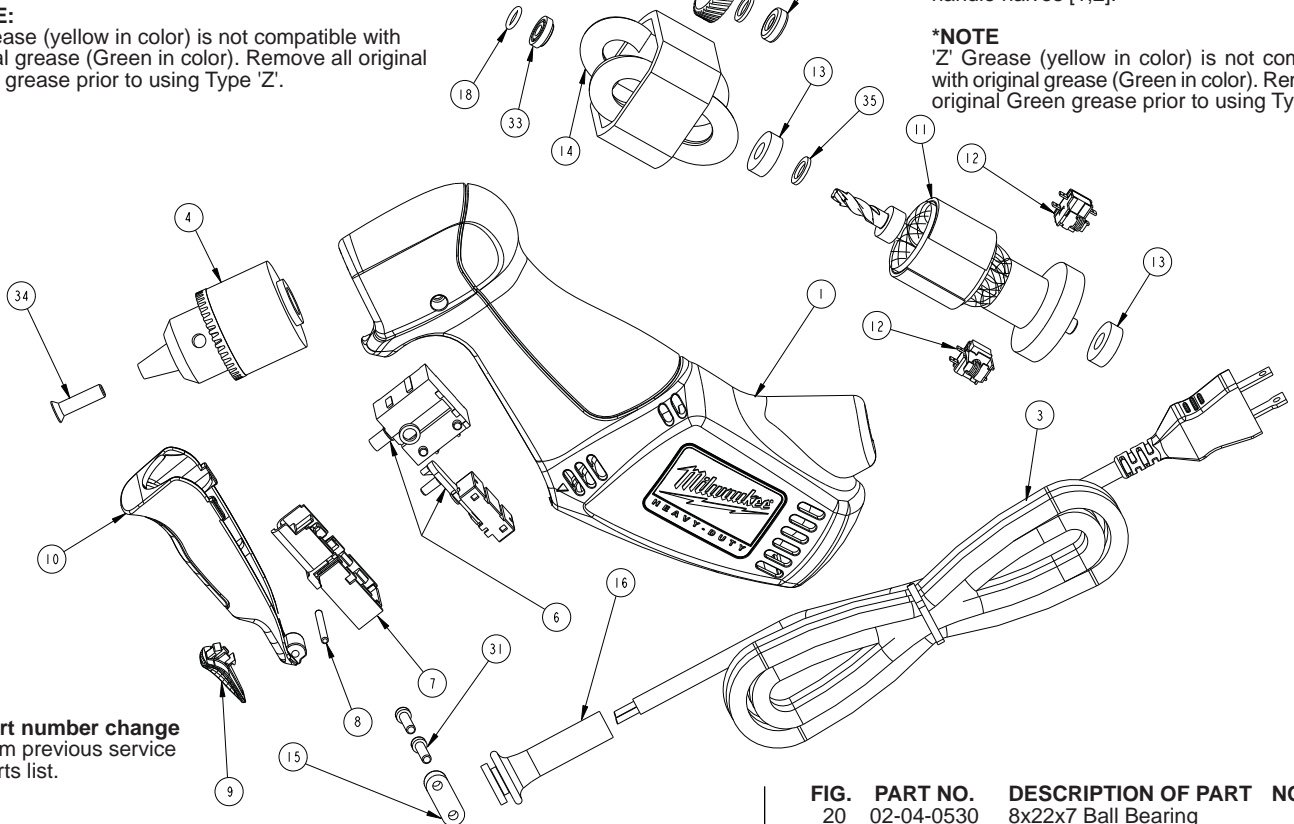

★ = Part number change from previous service parts list.

FIG.	PART NO.	DESCRIPTION OF PART	NO. REQ.
1	31-44-1575	Handle Half	(1)
2	31-44-1578	Handle Half	(1)
3	22-64-1822	Cord	(1)
4	48-66-1540	3/8" Drill Chuck	(1)
5	28-90-0300	Gear Box	(1)
6	23-66-1070	Switch	(1)
7	31-89-0040	F/R Switch Holder	(1)
8	06-65-0080	Steel Dowel Pin	(1)
9	45-24-0140	F/R Switch	(1)
10	45-72-0190	Switch Trigger	(1)
11	16-10-0840	Service Armature	(1)
12	22-22-0375	Brush Tube w/ Wires & Spring	(2)
13	02-04-0510	8x19x6 Ball Bearing	(2)
14	18-10-0175	Service Field	(1)
15	31-17-0300	Cord Clamp	(1)
16	44-76-0315	Cord Protector	(1)
17	02-04-0515	6x15x5 Ball Bearing	(1)
18	45-36-1670	O-ring, 7.4 ID x 1.8 Dia.	(2)
19	32-42-1100	Helical Gear	(1)
20	02-04-0530	8x22x7 Ball Bearing	(1)
21	32-60-2715	Bevel Pinion	(1)
★ 22	38-50-2415	Output Shaft	(1)
23	02-04-0540	10x22x6 Ball Bearing	(1)
★ 24	45-88-0885	Washer 9.2 ID x 17 OD	(2)
25	32-60-2710	Bevel Gear	(1)
26	02-04-0535	9x26x8 Ball Bearing	(1)
27	44-66-0315	Fastening Plate	(1)
28	05-74-0740	Screw M3.5 x 8	(7)
29	44-66-0320	Fastening Plate	(1)
30	05-74-0735	Screw M4 x10	(2)
31	05-74-0730	Set Screw M4 x 16	(9)
33	42-40-0145	Bushing	(1)
34	05-88-1440	Chuck Screw	(1)
35	45-88-0888	Washer 8.5 ID x 13 OD	(1)
42	45-88-0890	Washer 6.1 ID x 11 OD	(1)
	12-20-1372	Nameplate (Not Shown)	(1)
	48-66-3240	Chuck Key (Not Shown)	(1)
	48-66-4040	Chuck Key Holder (Not Shown)	(1)