



SERVICE PARTS LIST

BULLETIN NO.
54-06-0555

SPECIFY CATALOG NO. AND SERIAL NO. WHEN ORDERING PARTS		REVISED BULLETIN	DATE
1/2" MAGNUM HOLE-SHOOTER		54-06-0554	
CATALOG NO. 0244-1	STARTING SERIAL NO. 664-91086	WIRING INSTRUCTION 58-01-0077	

EXAMPLE:
Component Parts (Small #)
Are Included When Ordering
The Assembly (Large #).

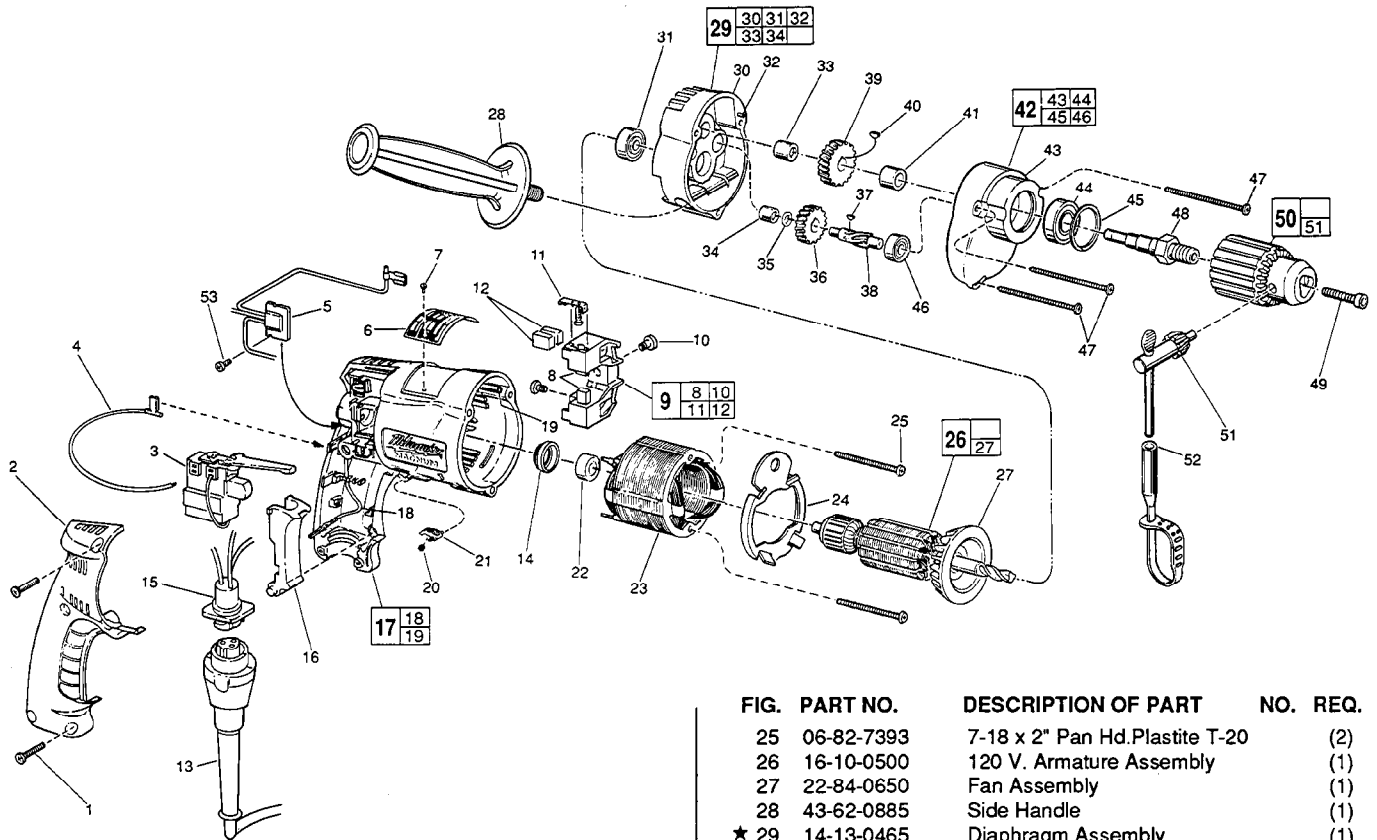

FIG.	PART NO.	DESCRIPTION OF PART	NO. REQ.
1	06-82-7266	7-1/8 x 11/16" Pan Hd. Plastite T-20	(5)
2	31-15-0401	Handle Cover	(1)
3	23-66-1665	Trigger Speed Control Reversing Switch	(1)
4	23-94-6245	2-1/4 Lead Assembly	(1)
5	14-20-0250	Remote Electronic Assembly	(1)
6	12-99-0071	Nameplate Blank	(1)
7	06-85-0200	Nameplate Screw	(2)
8	22-16-0275	Carbon Brush	(2)
9	22-22-0351	Brush Holder Assembly	(1)
10	31-75-0040	Brush Holder Screw	(2)
11	22-20-0345	Brush Spring Assembly	(2)
12	22-16-0275	Carbon Brush (Spare)	(2)
13	48-76-4008	Cord Set	(1)
14	22-72-0100	Bearing Cup	(1)
15	22-56-0630	Pin Housing Assembly	(1)
16	45-72-0080	Trigger	(1)
17	14-38-0540	Motor Housing Assembly	(1)
18	23-94-9960	Ground Wire Assembly	(1)
19	44-60-1290	Grounding Pin	(1)
20	40-50-0085	Lock Button Spring	(1)
21	42-42-0150	Lock Button	(1)
22	02-04-0645	Ball Bearing	(1)
23	18-11-0075	120 Volt Field	(1)
24	42-14-0345	Baffle	(1)

FIG.	PART NO.	DESCRIPTION OF PART	NO. REQ.
25	06-82-7393	7-18 x 2" Pan Hd. Plastite T-20	(2)
26	16-10-0500	120 V. Armature Assembly	(1)
27	22-84-0650	Fan Assembly	(1)
28	43-62-0885	Side Handle	(1)
★ 29	14-13-0465	Diaphragm Assembly	(1)
30	-----	Diaphragm	(1)
31	02-04-0847	Ball Bearing	(1)
32	06-65-0825	1/8 x 1/2 Groove Pin No. 5	(1)
33	02-50-2020	Needle Bearing	(1)
34	02-50-1620	Needle Bearing	(1)
35	45-88-7721	Heat Treated Washer	(1)
36	32-40-1815	Intermediate Gear	(1)
37	06-42-0400	Woodruff Key	(1)
38	36-66-4290	Intermediate Pinion	(1)
39	32-75-3040	Spindle Gear	(1)
40	06-42-1200	Woodruff Key	(1)
41	45-36-1100	Spacer	(1)
42	14-30-0335	Gear Case Assembly	(1)
43	-----	Gear Case	(1)
44	02-04-1229	Ball Bearing	(1)
45	34-80-2300	Retaining Ring	(1)
46	02-04-0640	Ball Bearing	(1)
47	06-82-7411	7-18 x 2-3/16" Pan Hd. Plastite T-20	(3)
48	38-50-5250	Spindle - Double Reduction	(1)
49	06-75-3150	1/4-20x1" Socket Hd. Screw-L.H. Thread	(1)
50	48-66-1365	1/2" Chuck	(1)
51	48-66-3280	Chuck Key	(1)
52	48-66-4040	Key Holder	(1)
53	06-82-7212	4-20x1/4" Pan Hd. Plastite T-10	(1)
	10-98-5986	Warning Label	(1)

FIG. LUBRICATION
43 1-1/2 Oz. Type "E" Grease, No. 49-08-4122.