



MANUAL

Catalog No.

No de Cat.

0233-20

0234-6

0235-21

0244-1

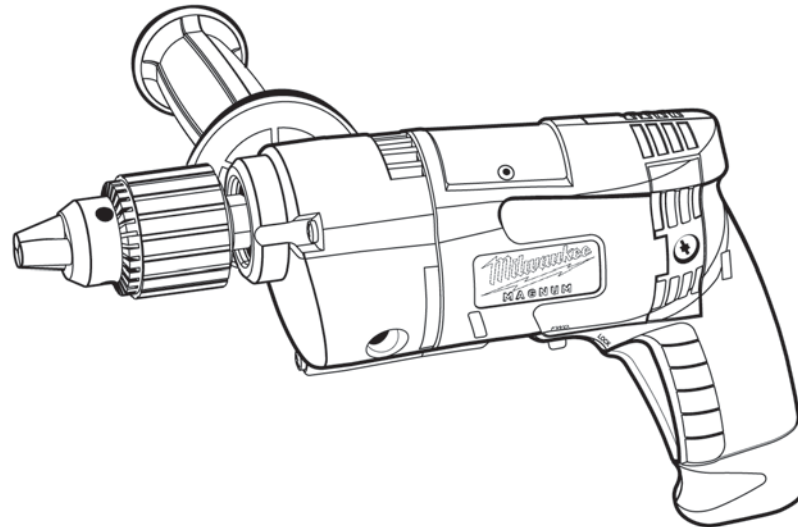

**HEAVY-DUTY MAGNUM DRILLS
EXTRA ROBUSTE PERCEUSES MAGNUM
TALADROS MAGNUM HEAVY-DUTY**

TO REDUCE THE RISK OF INJURY, USER MUST READ AND UNDERSTAND OPERATOR'S MANUAL.

GENERAL POWER TOOL SAFETY WARNINGS

⚠ WARNING READ ALL SAFETY WARNINGS AND ALL INSTRUCTIONS. Failure to follow the warnings and instructions may result in electric shock, fire and/or serious injury. **Save all warnings and instructions for future reference.** The term "power tool" in the warnings refers to your mains-operated (corded) power tool or battery-operated (cordless) power tool.

WORK AREA SAFETY

- **Keep work area clean and well lit.** Cluttered or dark areas invite accidents.
- **Do not operate power tools in explosive atmospheres, such as in the presence of flammable liquids, gases or dust.** Power tools create sparks which may ignite the dust or fumes.
- **Keep children and bystanders away while operating a power tool.** Distractions can cause you to lose control.

ELECTRICAL SAFETY

- **Power tool plugs must match the outlet. Never modify the plug in any way. Do not use any adapter plugs with earthed (grounded) power tools.** Unmodified plugs and matching outlets will reduce risk of electric shock.
- **Avoid body contact with earthed or grounded surfaces such as pipes, radiators, ranges and refrigerators.** There is an increased risk of electric shock if your body is earthed or grounded.
- **Do not expose power tools to rain or wet conditions.** Water entering a power tool will increase the risk of electric shock.
- **Do not abuse the cord. Never use the cord for carrying, pulling or unplugging the power tool. Keep cord away from heat, oil, sharp edges or moving parts.** Damaged or entangled cords increase the risk of electric shock.
- **When operating a power tool outdoors, use an extension cord suitable for outdoor use.** Use of a cord suitable for outdoor use reduces the risk of electric shock.
- **If operating a power tool in a damp location is unavoidable, use a ground fault circuit interrupter (GFCI) protected supply.** Use of an GFCI reduces the risk of electric shock.

PERSONAL SAFETY

- **Stay alert, watch what you are doing and use common sense when operating a power tool. Do not use a power tool while you are tired or under the influence of drugs, alcohol or medication.** A moment of inattention while operating power tools may result in serious personal injury.
- **Use personal protective equipment. Always wear eye protection.** Protective equipment such as dust mask, non-skid safety shoes, hard hat, or hearing protection used for appropriate conditions will reduce personal injuries.
- **Prevent unintentional starting. Ensure the switch is in the off-position before connecting to power source and/or battery pack, picking up or carrying the tool.** Carrying power tools with your finger on the switch or energising power tools that have the switch on invites accidents.

- **Remove any adjusting key or wrench before turning the power tool on.** A wrench or a key left attached to a rotating part of the power tool may result in personal injury.
- **Do not overreach. Keep proper footing and balance at all times.** This enables better control of the power tool in unexpected situations.
- **Dress properly. Do not wear loose clothing or jewellery. Keep your hair, clothing and gloves away from moving parts.** Loose clothes, jewellery or long hair can be caught in moving parts.
- **If devices are provided for the connection of dust extraction and collection facilities, ensure these are connected and properly used.** Use of dust collection can reduce dust-related hazards.

POWER TOOL USE AND CARE

- **Do not force the power tool. Use the correct power tool for your application.** The correct power tool will do the job better and safer at the rate for which it was designed.
- **Do not use the power tool if the switch does not turn it on and off.** Any power tool that cannot be controlled with the switch is dangerous and must be repaired.
- **Disconnect the plug from the power source and/or the battery pack from the power tool before making any adjustments, changing accessories, or storing power tools.** Such preventive safety measures reduce the risk of starting the power tool accidentally.
- **Store idle power tools out of the reach of children and do not allow persons unfamiliar with the power tool or these instructions to operate the power tool.** Power tools are dangerous in the hands of untrained users.
- **Maintain power tools. Check for misalignment or binding of moving parts, breakage of parts and any other condition that may affect the power tool's operation. If damaged, have the power tool repaired before use.** Many accidents are caused by poorly maintained power tools.
- **Keep cutting tools sharp and clean.** Properly maintained cutting tools with sharp cutting edges are less likely to bind and are easier to control.
- **Use the power tool, accessories and tool bits etc. in accordance with these instructions, taking into account the working conditions and the work to be performed.** Use of the power tool for operations different from those intended could result in a hazardous situation.

SERVICE

- **Have your power tool serviced by a qualified repair person using only identical replacement parts.** This will ensure that the safety of the power tool is maintained.

SPECIFIC SAFETY RULES

- Use auxiliary handle(s), if supplied with the tool. Loss of control can cause personal injury.
- Hold power tool by insulated gripping surfaces, when performing an operation where the cutting accessory may contact hidden wiring or its own cord. Cutting accessory contacting a "live" wire may make exposed metal parts of the power tool "live" and could give the operator an electric shock.
- Maintain labels and nameplates. These carry important information. If unreadable or missing, contact a MILWAUKEE service facility for a free replacement.
- WARNING Some dust created by power sanding, sawing, grinding, drilling, and other construction activities contains chemicals known to cause cancer, birth defects or other reproductive harm. Some examples of these chemicals are:
 - lead from lead-based paint
 - crystalline silica from bricks and cement and other masonry products, and
 - arsenic and chromium from chemically-treated lumber.
 Your risk from these exposures varies, depending on how often you do this type of work. To reduce your exposure to these chemicals: work in a well ventilated area, and work with approved safety equipment, such as those dust masks that are specially designed to filter out microscopic particles.

SPECIFICATIONS

Cat. No.	Volts AC	Amps	No Load RPM
0233-20	120	5.5	0-2800
0234-6	120	5.5	without RAD 0-950 RAD low 0-630 Rad high 0-1425
0235-21	120	5.5	0-950
0244-1	120	5.5	without RAD 0-700 RAD low 0-465 RAD high 0-1050

Right Angle Drive Unit Cat. No. 48-06-2871

FUNCTIONAL DESCRIPTION

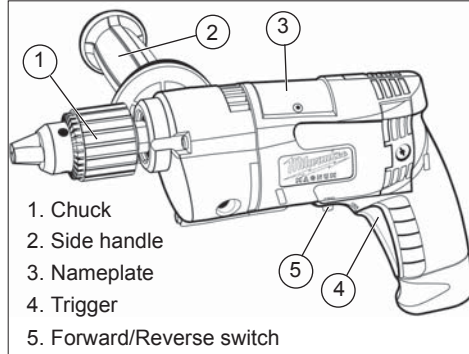

SYMBOLOLOGY

	Double Insulated
	Amps
	Volts
	Alternating Current Only
n_0 XXXXmin. ⁻¹	No Load Revolutions per Minute (RPM)
	Underwriters Laboratories, Inc. United States and Canada
	Mexican Approvals Marking

EXTENSION CORDS

Grounded tools require a three wire extension cord. Double insulated tools can use either a two or three wire extension cord. As the distance from the supply outlet increases, you must use a heavier gauge extension cord. Using extension cords with inadequately sized wire causes a serious drop in voltage, resulting in loss of power and possible tool damage. Refer to the table shown to determine the required minimum wire size.

The smaller the gauge number of the wire, the greater the capacity of the cord. For example, a 14 gauge cord can carry a higher current than a 16 gauge cord. When using more than one extension cord to make up the total length, be sure each cord contains at least the minimum wire size required. If you are using one extension cord for more than one tool, add the nameplate amperes and use the sum to determine the required minimum wire size.

Guidelines for Using Extension Cords

- If you are using an extension cord outdoors, be sure it is marked with the suffix "W-A" ("W" in Canada) to indicate that it is acceptable for outdoor use.
- Be sure your extension cord is properly wired and in good electrical condition. Always replace a damaged extension cord or have it repaired by a qualified person before using it.
- Protect your extension cords from sharp objects, excessive heat and damp or wet areas.

Recommended Minimum Wire Gauge For Extension Cords*

Nameplate Amperes	Extension Cord Length				
	25'	50'	75'	100'	150'
0 - 2.0	18	18	18	18	16
2.1 - 3.4	18	18	18	16	14
3.5 - 5.0	18	18	16	14	12
5.1 - 7.0	18	16	14	12	12
7.1 - 12.0	16	14	12	10	
12.1 - 16.0	14	12	10		
16.1 - 20.0	12	10			

* Based on limiting the line voltage drop to five volts at 150% of the rated amperes.

READ AND SAVE ALL INSTRUCTIONS FOR FUTURE USE.

GROUNDING

WARNING Improperly connecting the grounding wire can result in the risk of electric shock. Check with a qualified electrician if you are in doubt as to whether the outlet is properly grounded. Do not modify the plug provided with the tool. Never remove the grounding prong from the plug. Do not use the tool if the cord or plug is damaged. If damaged, have it repaired by a MILWAUKEE service facility before use. If the plug will not fit the outlet, have a proper outlet installed by a qualified electrician.

The grounding prong in the plug is connected through the green wire inside the cord to the grounding system in the tool. The green wire in the cord must be the only wire connected to the tool's grounding system and must never be attached to an electrically "live" terminal. Your tool must be plugged into an appropriate outlet, properly installed and grounded in accordance with all codes and ordinances. The plug and outlet should look like those in Figure A.

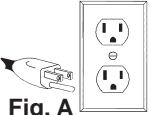

Fig. A

Double Insulated Tools: Tools with Two Prong Plugs

Tools marked "Double Insulated" do not require grounding. They have a special double insulation system which satisfies OSHA requirements and complies with the applicable standards of Underwriters Laboratories, Inc., the Canadian Standard Association and the National Electrical Code. Double Insulated tools may be used in either of the 120 volt outlets shown in Figures B and C.

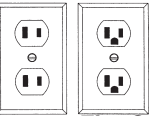

Fig. B



Fig. C

ASSEMBLY

WARNING To reduce the risk of injury, always unplug tool before changing or removing accessories. Only use accessories specifically recommended for this tool. Others may be hazardous.

WARNING To prevent personal injury, always remove the chuck key from the chuck after each use.

Installing Bits into Keyed Chucks (Cat. No. 0234-6, 0244-1)

Always unplug the tool before installing or removing bits.

1. Open the chuck jaws wide enough to insert the bit. Be sure the bit shank and chuck jaws are clean. Dirt particles may prevent the bit from lining up properly.
2. When using drill bits, insert the bit into the chuck. Center the bit in the chuck jaws and lift it about 1/16" off of the bottom. Tighten the chuck jaws by hand to align the bit. When using screwdriver bits, insert the bit far enough for the chuck jaws to grip the bit shank. Tighten the chuck jaws by hand to align the bit.
3. Place the chuck key in each of the three holes in the chuck, turning it clockwise as shown. Tighten securely.

Fig. 2

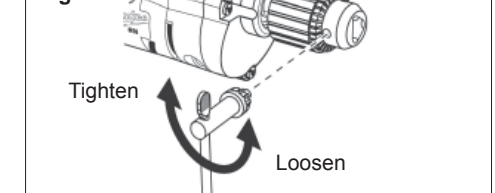

4. To remove the bit, insert the chuck key into one of the holes in the chuck and turn it counterclockwise.

Removing and Replacing Quik-Lok® Cords
MILWAUKEE's exclusive Quik-Lok® Cords provide instant field replacement or substitution.

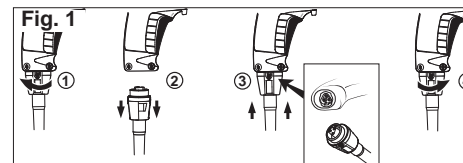

1. To remove the Quik-Lok® Cord, turn the cord nut 1/4 turn to the left and pull it out.
2. To replace the Quik-Lok® Cord, align the connector keys and push the connector in as far as it will go. Turn the cord nut 1/4 turn to the right to lock.

Installing Side Handle

MILWAUKEE Magnum Drills are supplied with a side handle that can be installed on either side of the tool for right or left handed use. To install the side handle, thread it into the socket on the desired side of the tool and tighten it securely. Always use the side handle for best control.

⚠ WARNING To reduce the risk of injury: Do not grasp the bit while the chuck is rotating or while the bit is falling from the chuck. Release the trigger as soon as the ratcheting stops to avoid throwing the bit.

Installing Bits into Keyless Chucks (Cat. No. 0233-20)

These tools are equipped with a hand-tightening keyless chuck. Always unplug the tool before installing or removing bits.

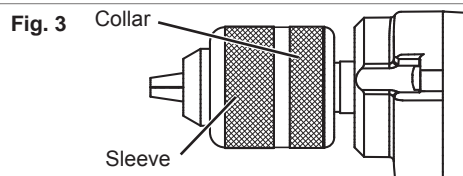

- To open the chuck jaws, turn the sleeve in the counterclockwise direction. When using drill bits, allow the bit to strike the bottom of the chuck. Center the bit in the chuck jaws and lift it about 1/16" off of the bottom. When using screwdriver bits, insert the bit far enough for the chuck jaws to grip the hex of the bit.
- To close the chuck jaws, hold the collar while turning the sleeve in the clockwise direction. Tighten securely.

Installing Bits into Keyless Chucks (Cat. No. 0235-21)

These tools are equipped with a spindle-lock mechanism and a single-sleeve keyless chuck. Always unplug the tool before inserting or removing bits.

- To open the chuck jaws, turn the chuck sleeve in counterclockwise direction.
- To install a bit, open the chuck jaws slightly wider than the bit. Center the bit in the chuck jaws and lift it about 1/16" off of the bottom. Align the bit as shown (Fig. 4).

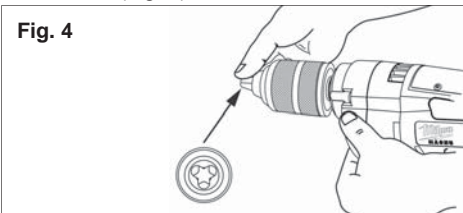

- To close the chuck jaws, turn the chuck sleeve in clockwise direction (Fig. 5). Tighten securely. Several detents will be felt as the chuck sleeve is turned.

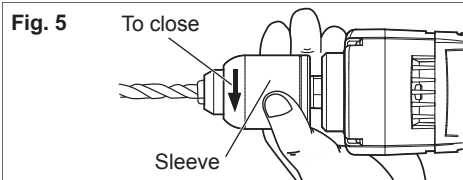

NOTE: If the spindle rotates when opening or closing the chuck jaws, grasp the chuck and slightly rotate back and forth to engage the spindle-lock mechanism. The spindle will remain locked until the tool is turned on. The spindle-lock mechanism will automatically disengage when the tool is turned on.

⚠ WARNING To reduce the risk of injury, wear safety goggles or glasses with side shields.

Chuck Removal

This tool is equipped with a threaded spindle to hold the chuck. Before removing the chuck, unplug the tool and open the chuck jaws. A left-handed thread screw is located inside the chuck to prevent the chuck from loosening when the tool is operated in reverse direction. Remove the screw by turning it clockwise. To remove the chuck, hold the tool so that only the side of the chuck rests firmly and squarely on a solid workbench. Insert the chuck key or a chuck remover bar in one of the keyholes. Turn the chuck so the key is at about a 30° angle to the bench top and strike the key sharply with a hammer so the chuck turns in a counterclockwise direction (looking from the front of the tool). This should loosen the chuck from the spindle which has a right hand thread making it easy to remove the chuck by hand.

NOTE: When replacing the chuck, always replace the left hand thread screw in the chuck.

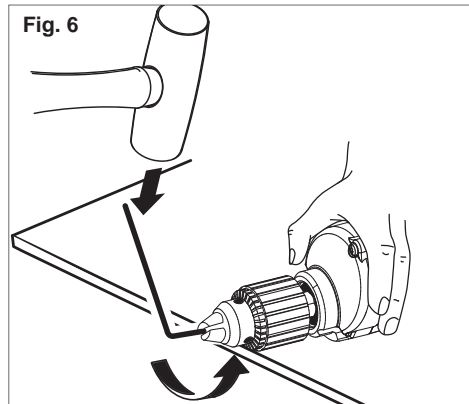

Attaching Right Angle Drive (RAD) to Drill

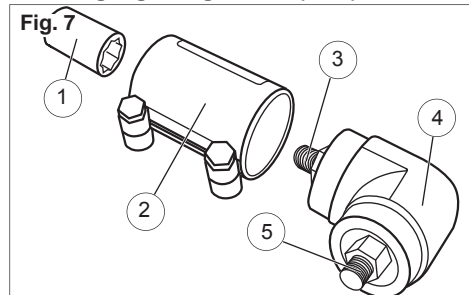

- Remove the chuck from the drill following instructions (See "Removing the Chuck From the Drill"). Slip the double hex coupling (1) over the hex on the drill spindle.

Loosen the clamping screws on the clamping sleeve (2) and slip the sleeve onto the drill collar.

- Slide the Right Angle Drive head (4) into the other side of the sleeve and turn the drive head slightly in either direction so the hexagonal hole in the coupling (1) engages the hexagonal portion of the spindle (3).

NOTE: Attaching the drill chuck to the side marked "LOW" reduces the speed by 1/3, or 33%. Attaching the drill chuck to the opposite side increases the speed by 50%.

- When assembled, turn the Right Angle Drive head to the desired position and tighten the clamping screws to secure the unit. Thread the chuck onto the Right Angle Drive spindle (5). **INSTALL CHUCK LOCKING SCREW.**

Removing the Chuck From RAD

The chuck can be removed from the Right Angle Drive Unit in the same manner it is removed from the drill; however, ALWAYS REMOVE RIGHT ANGLE DRIVE FROM THE DRILL BEFORE ATTEMPTING TO LOOSEN THE CHUCK. This will prevent damaging the drill's gearing. Use the open end wrench provided to hold the Right Angle Drive spindle before attempting to loosen the chuck.

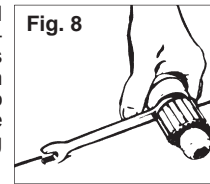

- For **forward** (clockwise) rotation, push the forward/reverse switch to **FWD** as shown.
- For **reverse** (counterclockwise) rotation, push the forward/reverse switch to **REV** as shown. Although an interlock prevents reversing the tool while the motor is running, allow it to come to a full stop before reversing.

⚠ WARNING To reduce the risk of injury, keep hands and cord away from the bit and all moving parts.

Starting, Stopping and Controlling Speed

- To **start** the tool, pull the trigger.
- To **stop** the tool, release the trigger.
- To **vary** the drilling speed, simply increase or decrease pressure on the trigger. The further the trigger is pulled, the greater the speed.

Locking Trigger

The lock button holds the trigger in the ON position for continuous full speed use.

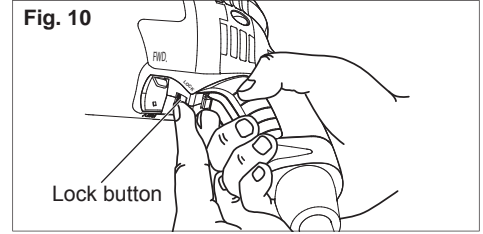

- To **lock** the trigger, hold the lock button in while pulling the trigger. Release the trigger.
- To **unlock** the trigger, pull the trigger and release. The lock button will pop out.

OPERATION

⚠ WARNING To reduce the risk of injury, always unplug tool before attaching or removing accessories or making adjustments. Use only specifically recommended accessories. Others may be hazardous.

⚠ WARNING To reduce the risk of injury, wear safety goggles or glasses with side shields.

Using Forward/Reverse Switch

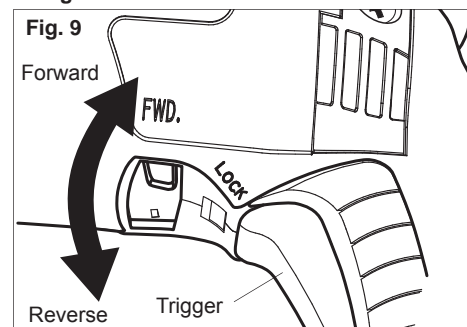

Drilling

- Before drilling, be sure the workpiece is clamped securely. Use backing material to prevent damage to the workpiece during breakthrough.
- When starting a hole, place the drill bit on the work surface and apply firm pressure. Begin drilling at a slow speed, gradually increasing the speed as you drill.
- Always apply pressure in line with the bit. Use enough pressure to keep the drill biting, but do not push hard enough to stall the motor.
- Reduce pressure and ease the bit through the last part of the hole. While the tool is still running, pull the bit out of the hole to prevent jamming.

Stalling

If the tool seems as if it is about to stall, maintain a firm grip and reduce pressure slightly to allow the bit to regain speed. If the tool does stall, release the trigger immediately. Reverse the motor, remove the bit from the work and start again. Do not pull the trigger on and off in an attempt to start a stalled drill. This can damage the drill.

APPLICATIONS

CAPACITIES

Cat. No.	Wood					Steel		Masonry
	Flat Boring Bits	Auger Bits	Ship Auger Bits	Selffeed Bits	Hole Saws	Twist Drill	Hole Saws	Carbide-Tipped Bits
0233-20	1"	N/R	N/R	N/R	1-3/4"	3/8"	1"	3/8"
0234-6	1-1/2"	1-1/2"	1-1/4"	2"	4"	1/2"	2"	1/2"
RAD low	1-1/2"	1-1/2"	1-1/2"	2-1/4"	4-1/2"	1/2"	2-1/8"	9/16"
RAD high	1-1/2"	1-1/8"	1"	1-1/2"	2-3/4"	1/2"	1-1/2"	7/16"
0235-21	1-1/2"	1-1/2"	1-1/4"	2"	4"	1/2"	2"	1/2"
0244-1	1-1/2"	1-1/2"	1-1/2"	2-1/4"	4-1/2"	1/2"	2-1/4"	9/16"
RAD low	1-1/2"	1-1/2"	1-1/2"	2-9/16"	5"	1/2"	2-1/4"	5/8"
RAD high	1-1/2"	1-1/2"	1-1/4"	1-3/4"	3-1/4"	1/2"	1-3/4"	1/2"

Selecting Bits

When selecting a bit, use the right type for your job. For best performance, always use sharp bits.

Drilling in Wood, Composition Materials and Plastic

When drilling in wood, composition materials and plastic, start the drill slowly, gradually increasing speed as you drill. When using twist drill bits, pull the bit out of the hole frequently to clear chips from the bit flutes. Use low speeds for plastics with a low melting point.

Drilling in Masonry

When drilling in masonry, use high speed carbide-tipped bits. Drilling soft masonry materials such as cinder block requires little pressure. Hard materials like concrete require more pressure. A smooth, even flow of dust indicates the proper drilling rate. Do not let the bit spin in the hole without cutting. Do not use water to settle dust or to cool bit. Both actions will damage the carbide.

Drilling in Metal

When drilling in metal, use high speed steel twist drills or hole saws. Use slow speeds for hard metals and high speeds for softer metals. Lubricate drill bits with cutting oil when drilling in iron or steel. Use a coolant when drilling in nonferrous metals such as copper, brass or aluminum. Back the material to prevent binding and distortion on breakthrough.

Driving Screws

When driving screws, use the proper screwdriver bit for your job. After drilling pilot and shank holes, start the screw slowly and increase the speed as driving progresses. Set the screw by slowing to a stop. Do not run screws down at excessive speeds. To remove screws, reverse the motor.

WARNING High rotational force. To reduce the risk of injury, always hold or brace securely. Always use side handle on tools rated 1200 RPM or less.

Bit Binding

A high rotational force occurs when a bit binds. If the bit binds, the tool will be forced in the opposite direction of the bit rotation (See Fig. 11 - 13). Bits may bind if they are misaligned or when they are breaking through a hole. Wood boring bits can also bind if they run into nails or knots. Be prepared for bit binding situations.

To reduce the chance of bit binding:

- Use sharp bits. Sharp bits are less likely to bind when drilling.
- Use the proper bit for the job. There are bits that are designed for specific purposes.
- Use caution when drilling pitchy, knotty, wet or warped material or when drilling in material that may contain nails.

Typical Bracing Methods

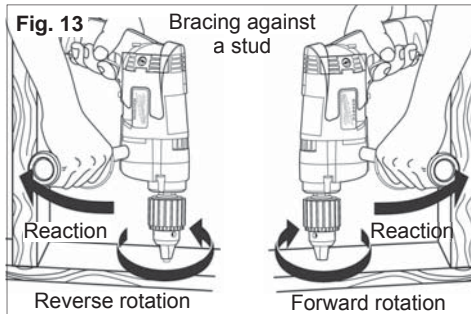
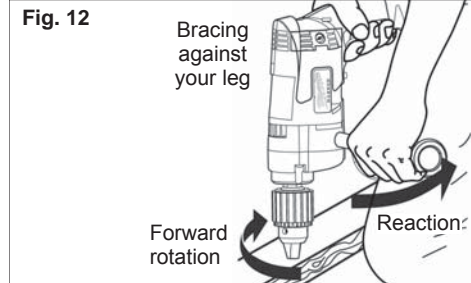
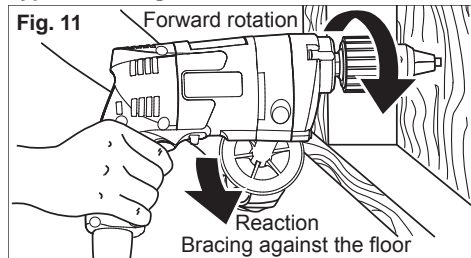

MAINTENANCE

WARNING To reduce the risk of injury, always unplug your tool before performing any maintenance. Never disassemble the tool or try to do any rewiring on the tool's electrical system. Contact a MILWAUKEE service facility for ALL repairs.

Replacing Brushes

MILWAUKEE Magnum Drills have an exclusive Brush Cartridge System. The tool will not start when the brushes are worn to 1/8", preventing expensive damage to the armature. New brushes are provided in the Cartridge for fast changes anywhere.

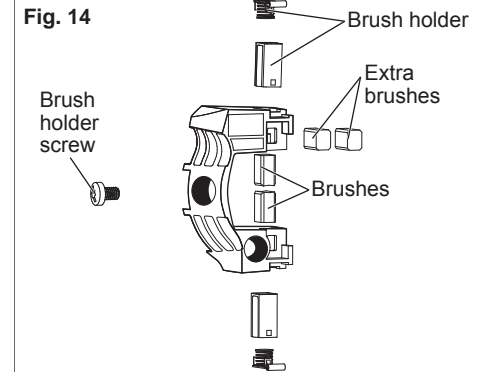

1. Unplug tool and rest it on its side with the cartridge facing up. Loosen the brush holder screw in the cartridge and pull cartridge out.

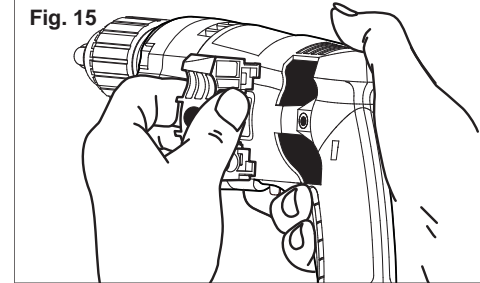

2. Remove worn brushes. If the brushes should fall into the tool, be sure to shake them out before reinserting the cartridge. Discard BOTH brushes. Brushes should always be replaced in sets.
3. A set of spare brushes is provided in the cartridge. Remove the brushes from storage compartment.
4. Position new brushes with the flat silver end facing into the brush holder. Push cartridge into the tool and press evenly on top and bottom of the cartridge to align terminals for proper connection.
5. Tighten the brush holder screw gently. If the head of screw is damaged, use only MILWAUKEE replacement parts.

WARNING Never use a different screw as a brush holder screw.

Maintaining Tools

Keep your tool in good repair by adopting a regular maintenance program. Before use, examine the general condition of your tool. Inspect guards, switches, tool cord set and extension cord for damage. Check for loose screws, misalignment, binding of moving parts, improper mounting, broken parts and any other condition that may affect its safe operation. If abnormal noise or vibration occurs, turn the tool off immediately and have the problem corrected before further use. Do not use a damaged tool. Tag damaged tools "DO NOT USE" until repaired (see "Repairs").

Under normal conditions, relubrication is not necessary until the motor brushes need to be replaced. After six months to one year, depending on use, return your tool to the nearest MILWAUKEE service facility for the following:

- Lubrication
- Brush inspection and replacement
- Mechanical inspection and cleaning (gears, spindles, bearings, housing, etc.)
- Electrical inspection (switch, cord, armature, etc.)
- Testing to assure proper mechanical and electrical operation

WARNING To reduce the risk of injury, electric shock and damage to the tool, never immerse your tool in liquid or allow a liquid to flow inside the tool.

Cleaning

Clean dust and debris from vents. Keep the tool handles clean, dry and free of oil or grease. Use only mild soap and a damp cloth to clean your tool since certain cleaning agents and solvents are harmful to plastics and other insulated parts. Some of these include: gasoline, turpentine, lacquer thinner, paint thinner, chlorinated cleaning solvents, ammonia and household detergents containing ammonia. Never use flammable or combustible solvents around tools.

Repairs

If your tool is damaged, return the entire tool to the nearest service center.

ACCESSORIES

WARNING To reduce the risk of injury, always unplug the tool before attaching or removing accessories. Use only specifically recommended accessories. Others may be hazardous.

To obtain a catalog, contact your local distributor or a service center.