

WIRING INSTRUCTIONS

TITLE **DOUBLE REDUCTION PISTOL GRIP TOOLS**

**BULLETIN
58-01-1805**

**FOR DOUBLE INSULATED TOOLS
DISREGARD GREEN GROUND WIRE #3
AND THE GROUNDING TERMINAL**

Grounding terminal

Green ground wire #3 connects to male tab of grounding terminal. Position terminal as shown. (Grounded models only).

Route blue brush wire #5 and white brush wire #6 through wire traps over rear bearing bore as shown.

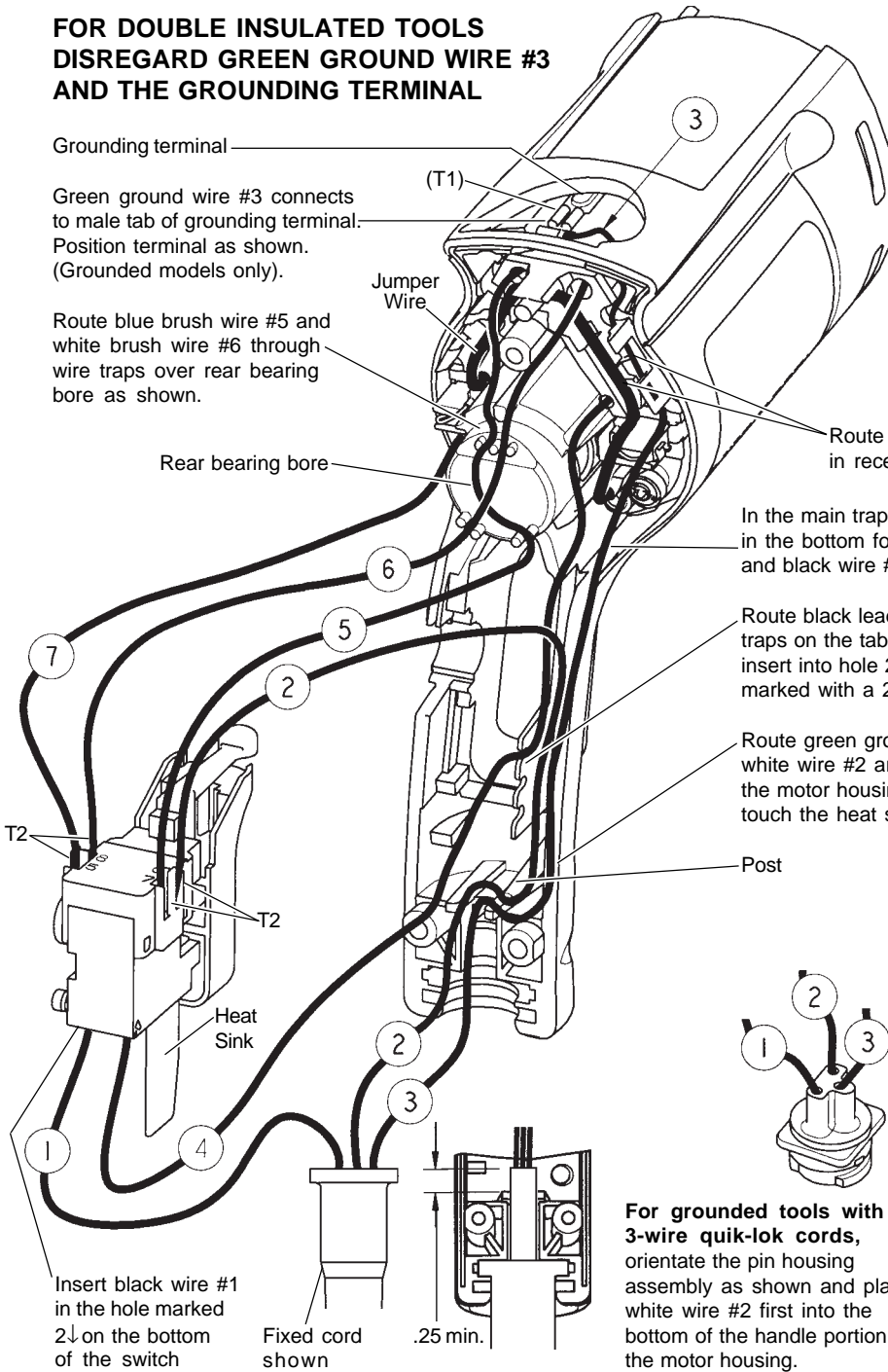

Route green ground wire #3 and jumper wire (white) in recessed area of brush card as shown.

In the main trap, route green ground wire #3 in the bottom followed by the white wire #2 and black wire #4 on the top.

Route black lead #4 through any of the three traps on the tab of the motor housing and insert into hole 2 on bottom of switch (Hole is marked with a 2 on side of switch).

Route green ground wire #3 and white wire #2 around the post in the motor housing. Wires cannot touch the heat sink of the switch.

Post

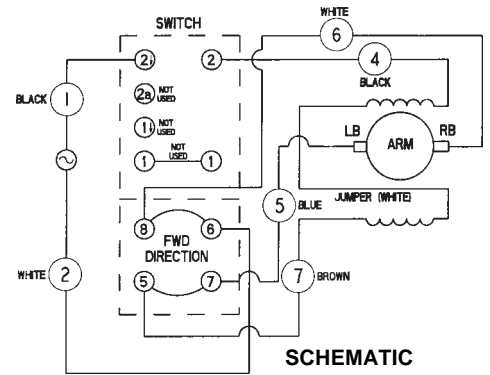

SCHEMATIC

Black wire #1 Black wire #4

If screw is present seat screw fully.

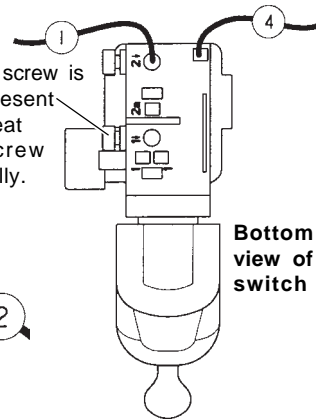

Bottom view of switch

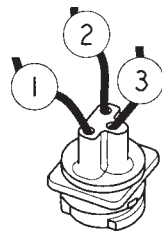

For grounded tools with 3-wire quik-lok cords, orientate the pin housing assembly as shown and place white wire #2 first into the bottom of the handle portion of the motor housing.

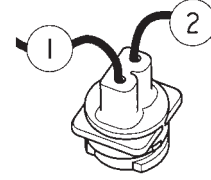

For double insulated tools with 2-wire quik-lok cords, orientate the blade housing assembly as shown and place white wire #2 first into the bottom of the handle portion of the motor housing.

WIRING SPECIFICATIONS

Wire No.	Wire Color	Origin or Gauge	Length	Terminals, Connectors and 1 or 2 End Wire Preparation
1	Black	*	----	*Component of cord set, pin hsg. assy. or blade hsg. assy.
2	White	*	----	*Component of cord set, pin hsg. assy. or blade hsg. assy.
3	Green	*	----	*Component of cord set, pin hsg. assy. or blade hsg. assy.
4	Black	**	----	**Component of the brush card assembly.
5	Blue	**	----	**Component of the brush card assembly.
6	White	**	----	**Component of the brush card assembly.
7	Brown	**	----	**Component of the brush card assembly.

TERMINAL DESCRIPTION

Code	Part No.	Qty.
T1	23-74-0605	1
T2	23-74-1060	4

WIRING INSTRUCTIONS

TITLE

DOUBLE REDUCTION PISTOL GRIP TOOLS

**BULLETIN
58-01-1806**

**FOR DOUBLE INSULATED TOOLS
DISREGARD GREEN GROUND WIRE #3
AND THE GROUNDING TERMINAL**

Grounding terminal
Green ground wire #3 connects to male tab of grounding terminal. Position terminal as shown. (Grounded models only).

Route blue brush wire #5 and white brush wire #6 through wire traps over rear bearing bore as shown.

Route green ground wire #3 and jumper wire (white) in recessed area of brush card as shown.

In the main trap, route green ground wire #3 in the bottom followed by the white wire #2 and black wire #4 on the top.

Route black lead #4 through any of the three traps on the tab of the motor housing and insert into hole 2a on bottom of switch. (Hole is marked with a 2a on side of switch).

Route green ground wire #3 and white wire #2 around the post in the motor housing.

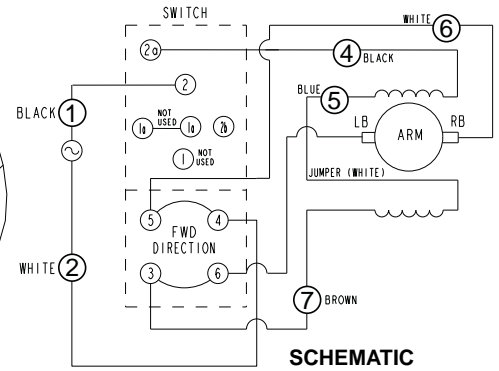
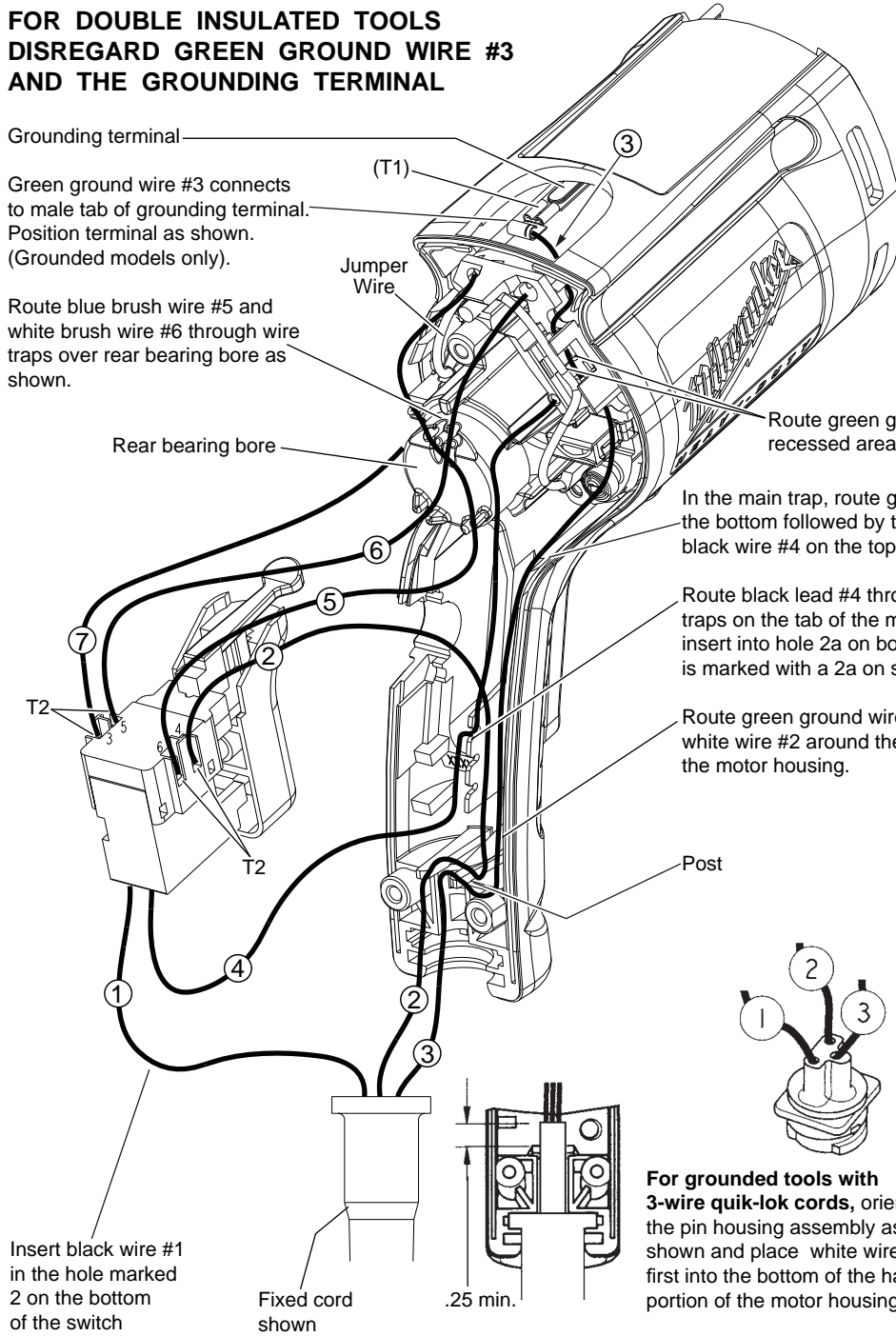

SCHEMATIC

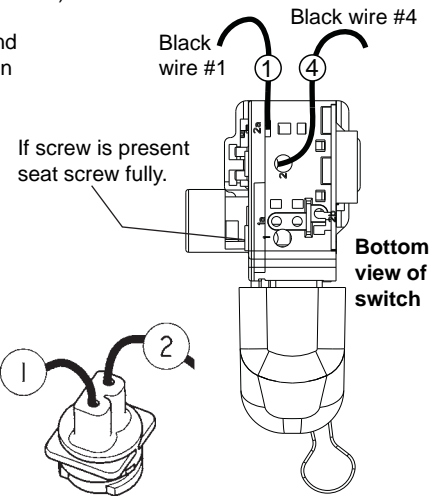

Insert black wire #1 in the hole marked 2 on the bottom of the switch

Fixed cord shown

.25 min.

For grounded tools with 3-wire quik-lok cords, orientate the pin housing assembly as shown and place white wire #2 first into the bottom of the handle portion of the motor housing.

For double insulated tools with 2-wire quik-lok cords, orientate the blade housing assembly as shown and place white wire #2 first into the bottom of the handle portion of the motor housing.

WIRING SPECIFICATIONS

Wire No.	Wire Color	Origin or Gauge	Length	Terminals, Connectors and 1 or 2 End Wire Preparation
1	Black	*	----	*Component of cord set, pin hsg. assy. or blade hsg. assy.
2	White	*	----	*Component of cord set, pin hsg. assy. or blade hsg. assy.
3	Green	*	----	*Component of cord set, pin hsg. assy. or blade hsg. assy.
4	Black	**	----	**Component of the brush card assembly.
5	Blue	**	----	**Component of the brush card assembly.
6	White	**	----	**Component of the brush card assembly.
7	Brown	**	----	**Component of the brush card assembly.

BULK LEAD WIRE - BULLETIN NO. 58-01-0003

TERMINAL DESCRIPTION

Code	Part No.	Qty.
T1	23-74-0605	1
T2	23-74-1060	4