

INSTRUCTIONS FOR USING THE DOUBLE-FLARING TOOL

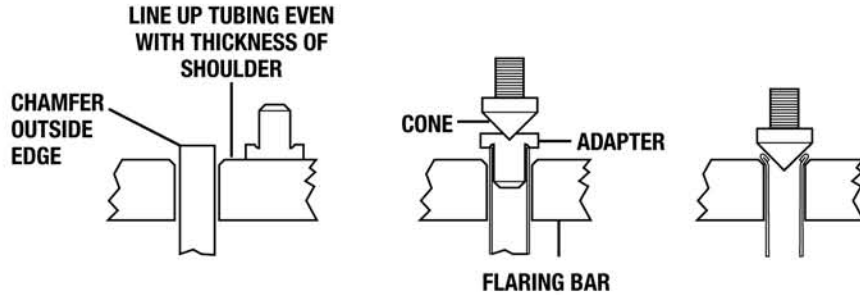

FLARING

1. Loosen the two wing nuts on the flaring bar.
2. Squarely cut a piece of tubing and remove any burrs. Chamfer the outside edge with an ordinary file. **REAM TUBING SO PROPER SIZED ADAPTER FITS FREELY INSIDE. DO NOT FORCE! REAM AGAIN IF NECESSARY.**
3. Insert the tubing into the proper sized hole. The tubing should extend a distance equal to the width of the shoulder on the corresponding adapter. A set of five adapters is included: 1/2, 3/8, 5/16, 1/4 and 3/16".
4. Tighten the wing nut closest to the tube first, then tighten the other one. Nuts must be securely tightened so there is no chance of the tube slipping.
5. Place a drop of oil on the proper sized adapter and insert all the way into tubing. Slide the yoke over the bar and line up the flaring cone with the adapter. **MAKE SURE THE ADAPTER IS STRAIGHT.** Slightly turn the yoke clockwise to lock into place. Secure this locked position with thumb and forefinger.

6. Screw down one flaring cone until it engages with the adapter. **MAKE SURE THAT THE ADAPTER IS CENTERED IN THE TUBING.** If so, begin screwing down the cone until the shoulder of the adapter rests on the flaring bar. This completes the beelling operation.
7. Now, back off the flaring cone slightly and remove the adapter. Screw the cone down tightly onto the tubing. This procedure folds the tubing back on itself, forming a 45° double flare.

PARTS LIST

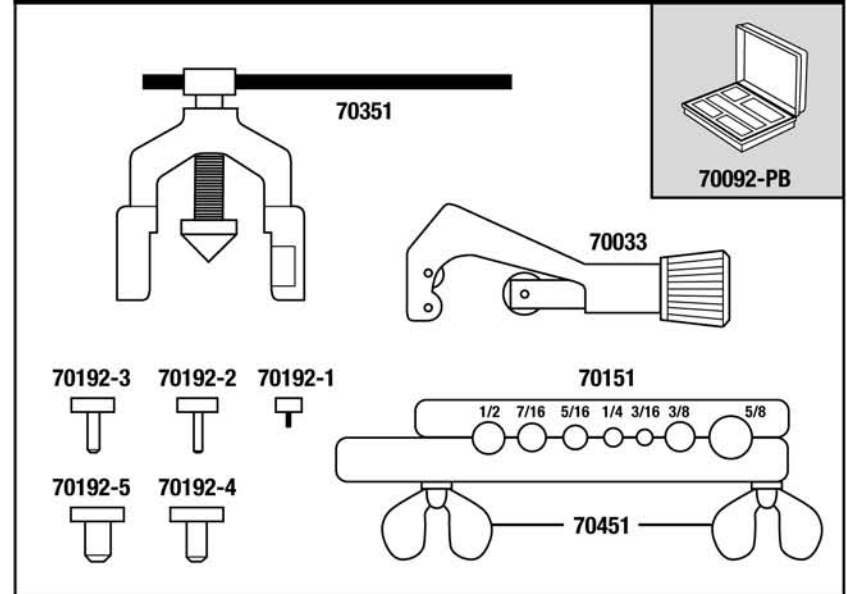

Mastercool[®]
"World Class Quality"

70092 INS LBL