

CIRCULAR LASER INFRARED THERMOMETER

Reads Real-Time Maximum (MAX) data.

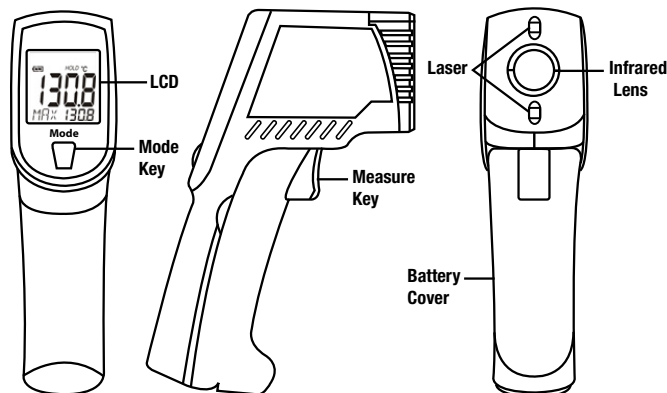

Please remember to keep away from children and don't use it for safety related applications.

1. Simply aim the thermometer at the target with Lens (4) and press Meas. key (3) to display the surface temperature.
2. During the measurement, the MAX reading will be displayed beside the MAX icon.
3. The Distance:Spot is 12:1. Please make sure the target area is within the field of view.

°C or °F Press Mode key (2) for °C or °F.

Backlight LCD Backlight is always on.

Laser Class II Laser: always enabled while measuring.

EMC/RFI

Readings may be affected if the unit is operated within radio frequency electromagnetic field strength of approximately 3 volts per meter, but the performance of the instrument will not be permanently affected.

* **Note: Under the electromagnetic field of 3V/m from 200 to 600 MHz, the maximum error is 10°C (18°F).**

CAUTION

1. When device is in use, do not look directly into the laser beam. Permanent eye damage may result.
2. Use extreme caution when operating the laser.
3. Never point the device towards anyone's eyes.
4. Keep out of reach of all children.

STORAGE & CLEANING

Unit should be stored at room temperature. The sensor lens is the most delicate part of the thermometer. The lens should be kept clean at all times, care should be taken when cleaning the lens using only a soft cloth or cotton swab with water or medical alcohol, allowing the lens to fully dry before using the thermometer. Do not submerge any part of the thermometer.

LCD ERROR MESSAGES

The thermometer incorporates visual diagnostic messages as follows:

'Er2': is displayed when the thermometer is exposed to rapid changes in the ambient temperature.

'Er3': is displayed when the ambient temperature exceeds 0°C (32°F) or 50°C (122°F). The thermometer should be allowed plenty of time (minimum 30 minutes) to stabilize to the working/room temperature.

'Er': Error 5~9, for all other error messages it is necessary to reset the thermometer. To reset, turn the instrument off, remove the battery and wait for a minimum of one minute, reinsert the battery and turn on. If the error message remains please contact the Service Department for further assistance.

'Hi' or 'Lo': is displayed when the temperature being measured is outside of the measurement range.

BATTERIES

The thermometer incorporates visual low battery indication as follows:



'Battery OK': measurements are possible



'Battery Low': battery needs to be replaced, measurements are still possible



'Battery Exhausted': measurements are not possible

When the 'Low Battery' icon indicates the battery is low, the battery should be replaced immediately with AAA, 1.5V batteries. Please note: It is important to turn the instrument off before replacing the battery otherwise the thermometer may malfunction. Dispose of used battery promptly and keep away from children.

SPECIFICATION

Measurement Range	-60 to 760°C (-76 to 1400°F)
Operating Range	0 to 50°C (32 to 122°F)
Accuracy	±2% of reading or 2°C (4°F)
Emissivity	0.95 fixed
Resolution	0.1°C/0.1°F at -76 to 999.9°C/°F, otherwise 1°C/1°F
Response Time (90%)	1 sec
Distance:Spot	12:1 (90% energy covered)
Battery Life	14 hrs continuous use (Alkaline, with Laser and Back Light.)
Dimensions	255 x 135 x 67mm (10.04 × 5.31 × 2.64")
Weight	390g (13.75oz) including batteries (AAA (2pcs))

** The thermometer will automatically shut off if left idle for more than 15 sec.