

Makita®

10-1/4" CIRCULAR SAW

LARGE CUTTING CAPACITIES (3-3/4" at 90°) FOR CUTTING 4X MATERIAL IN A SINGLE PASS

14 AMP Motor Delivers Enough Power to Cut Beams and Timber

Well Balanced and Weighs only 18.3 lbs. for Better Control

Electric Brake for Maximum Productivity

Ideal for Framers, Roofers and Carpenters for Cutting Timber and Beams and Dimensional, Engineered and Wet Lumber

ACCURACY

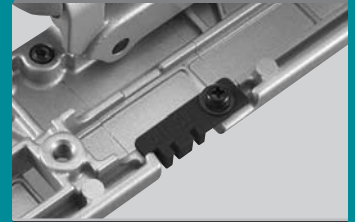

Adjustable top guide to align notches with line of cut for accurate cutting

CONVENIENCE



Flat motor housing design for increased convenience when changing the blade

EFFICIENCY



Large, conveniently located adjustment knobs and levers increase productivity

PERFORMANCE



Large ejection port efficiently discards saw dust

**Model
5104**

CUTS 4X MATERIAL

10-1/4" CIRCULAR SAW

Model 5104

FEATURES & BENEFITS

- 14 AMP motor delivers enough power to cut beams and timber
- Large cutting and bevel capacity (3-3/4" at 90° and 2-3/4" at 45°)
- Electric brake for maximum productivity
- Precision gearing with ball and needle bearing construction for smooth and efficient power transmission
- Well balanced and weighs only 18.3 lbs. for better control
- Blade wrench is attached to the saw for fast and convenient blade changing
- Front, top and rear handles are positioned to fit hands comfortably for better control

STANDARD EQUIPMENT

- Carbide tipped blade (A-94910)
- Blade wrench (783204-6)
- Rip fence (165499-7)

SPECIFICATIONS

Blade Diameter	10-1/4"
Arbor	5/8"
Max. Cutting Capacity at 90°	3-3/4"
Max. Cutting Capacity at 45°	2-3/4"
No Load RPM	3,800
Watts Out	2,100
AMPS (120V)	14.0
Length	16"
Net Weight	18.3 lbs.
Shipping Weight	26.5 lbs.
UPC Code	088381-08882-4

OPTIONAL ACCESSORIES

- Blade wrench (783204-6)
- Rip fence (164095-8)
- 10-1/4" C.T. saw blades

Description	No. Teeth	Part #
Framing	24	A-94910
Fine Crosscutting	64	721424-4

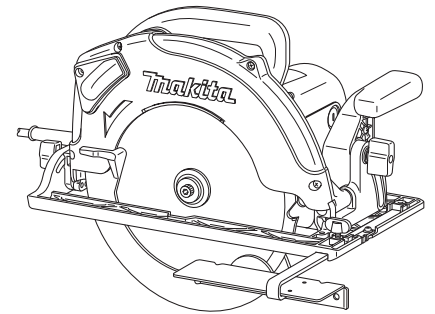

Learn more about power saws we have.