

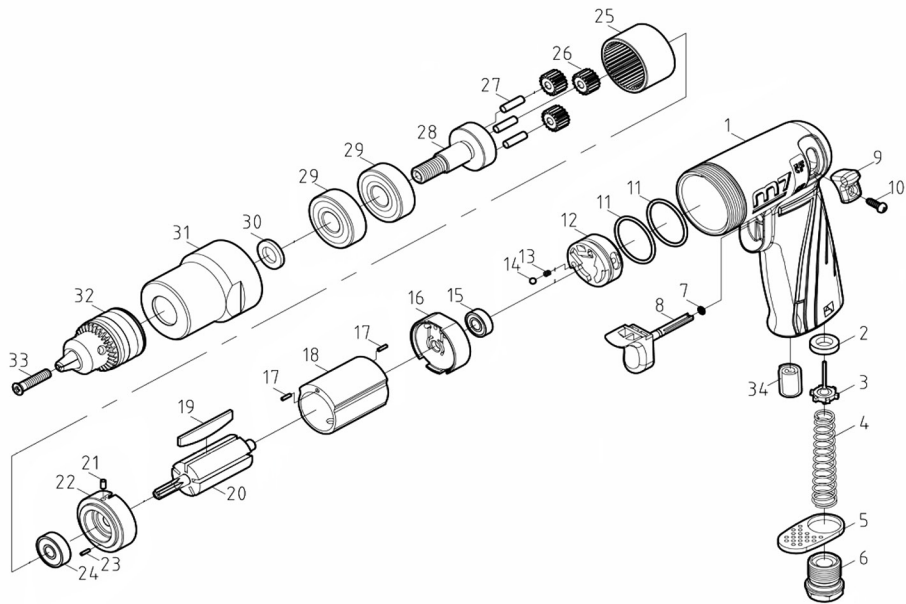

Air Reversible Drill

Item No : QE-323N

● The consumable parts ▲ The replacement parts ★ The non-replacement parts



Part List

Air Reversible Drill

QE-323N



NO.	Part No.	Description	Q'TY
★	1	QE-323P01 Housing	1
★	2	QE-323P02 Oil Seal	1
★	3	QE-323P03 Pin Valve Rod	1
★	4	QE-323P04 Cone Spring	1
★	5	QE-323P05 Exhaust Deflector	1
★	6	QE-323P06A Air Inlet, 19PT	1
★		QE-323P06B Air Inlet, 18NPT	1
●	7	QE-323P07 O-Ring	1
★	8	QE-323P08 Trigger	1
★	9	QE-323P09 Reverse Lever	1
★	10	QE-323P10 Screw	1
●	11	QE-323T11 O-Ring (2 pcs)	1 SET
★	12	QE-323P12 Rear Plate Spacer	1
★	13	QE-323P13 Spring	1
★	14	QE-323P14 Steel Ball	1
●	15	QE-323P15 Ball Bearing	1
▲	16	QE-323P16 Rear Plate	1
★	17	QE-323T17 Spring Pin (2 pcs)	1 SET
★	18	QE-323P18 Cylinder	1
●	19	QE-323T19 Rotor Blade (5 pcs)	1 SET
★	20	QE-323P20 Rotor	1
▲	21	QE-323P21 Spring Pin	1
▲	22	QE-323P22 Front Plate	1
▲	23	QE-323P23 Pin	1
●	24	QE-323P24 Ball Bearing	1
★	25	QE-323P25 Internal Gear	1
●	26	QE-323T26 Gear (3 pcs)	1 SET
★	27	QE-323T27 Pin (3 pcs)	1 SET
★	28	QE-323P28 Gear Carrier	1
●	29	QE-323T29 Ball Bearing (2 pcs)	1 SET
★	30	QE-323P30 Washer	1
★	31	QE-323P31 Front Casing	1
★	32	QE-323P32 Chuck	1
★	33	QE-323P33 Screw	1
▲	34	QE-323P34 Muffler Filter	1