

Follower assembly

Model 83366, 83369, 278964 and 278965

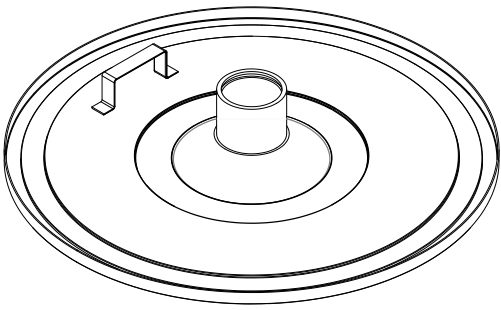

Date of issue **July 2014**

Form number **403348B**

Section **K5**

Page **9B**

⚠ DANGER

Read manual prior to installation or use of this product. Keep manual nearby for future reference. Failure to follow instructions and safety precautions may result in death or serious injury.

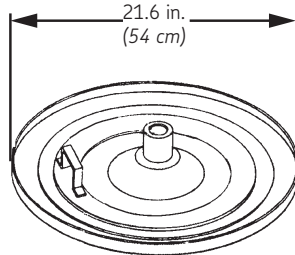
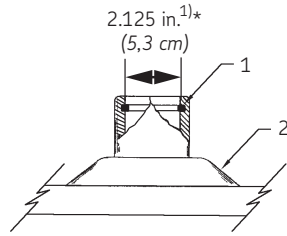

83369 follower
400 lb. (181 kg) drum
Standard PowerMaster

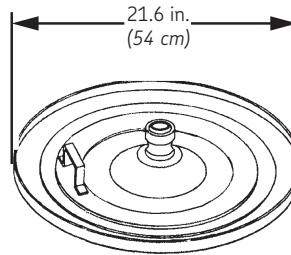
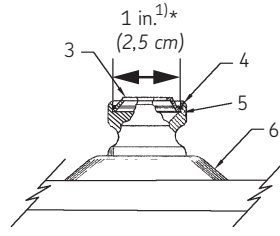

83366 follower
400 lb. (181 kg) drum
Series 20 and 40

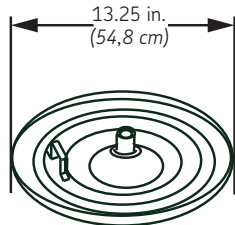
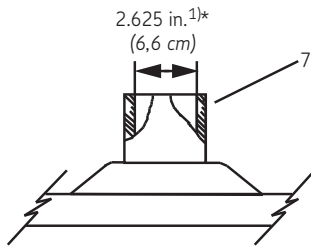

278964 follower
120 lb. (54 kg) drum
Ultra high pressure PowerMaster

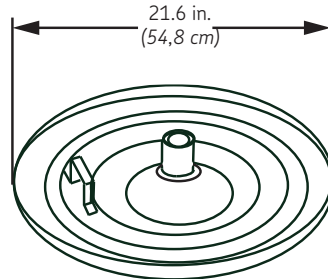
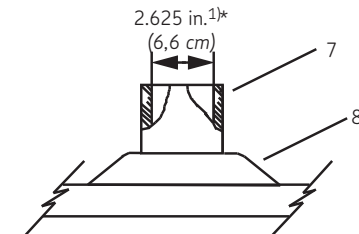

278965 follower
400 lb. (181 kg) drum
Ultra high pressure PowerMaster

Service parts

Item no.	Part no.	Qty.	Description
1	34337	1	O-ring
2	91957	1	Follower plate
3	13097	1	Gasket guard
4	68411	1	Retaining ring
5	38067	1	Flat washer
6	91954	1	Follower plate
7	278992	1	O-ring
8	278962	1	Follower

¹⁾ Pump tube diameters
* Indicates change

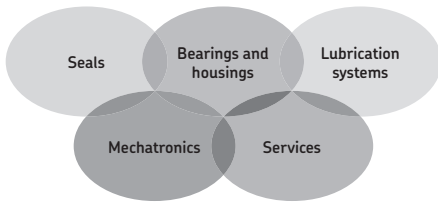

The Power of Knowledge Engineering

Combining products, people, and application-specific knowledge, SKF delivers innovative solutions to equipment manufacturers and production facilities in every major industry worldwide. Having expertise in multiple competence areas supports SKF Life Cycle Management, a proven approach to improving equipment reliability, optimizing operational and energy efficiency and reducing total cost of ownership.

These competence areas include bearings and units, seals, lubrication systems, mechatronics, and a wide range of services, from 3-D computer modelling to cloud-based condition monitoring and asset management services.

SKF's global footprint provides SKF customers with uniform quality standards and worldwide product availability. Our local presence provides direct access to the experience, knowledge and ingenuity of SKF people.

LINCOLN

