

120 LB. DRUM SIZE 50:1 RATIO

WARNING

Do not operate this unit
with combustible gas

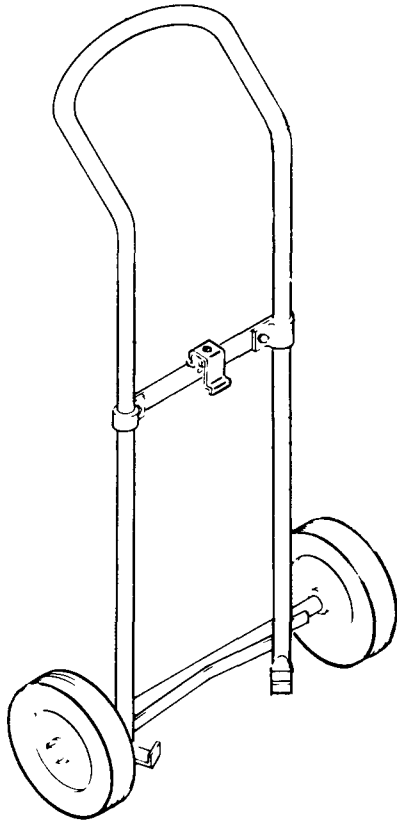

674 DOLLY TRUCK

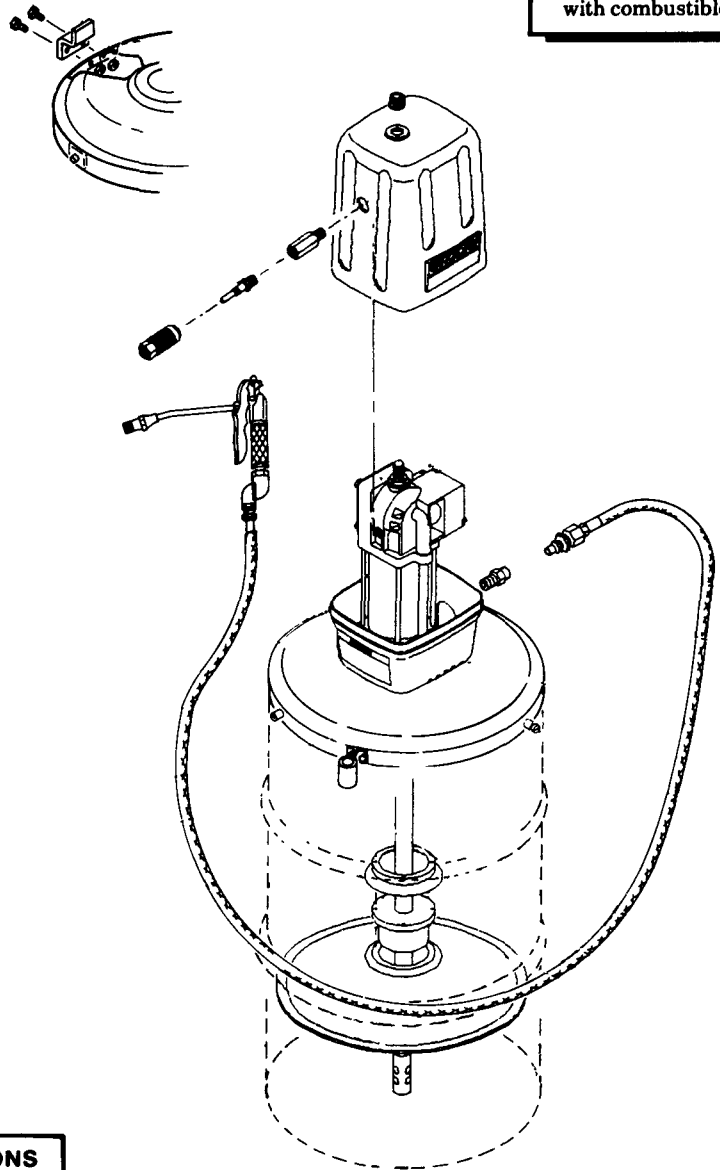

917-57 PORTABLE LUBRIGUN

*** REFER TO SEPARATE INSTRUCTIONS**

674	Dolly Truck
917-57	Portable Lubrigun

INSTRUCTIONS FOR ASSEMBLING LUBRIGUN:

- 1) Assemble drum cover to pump.
 - a) Remove cover nut from top of pump. Lift airmotor cover from pump.
 - b) Remove the four screws holding the cover-bottom to the pump outlet body.
 - c) Hold pump with pump outlet body resting securely on the inner surface of the cover-bottom. Insert end of pump tube through hole in drum cover. Line up holes in drum cover, cover-bottom and pump outlet body. Replace the four screws and tighten securely.
- 2) Remove drum top.
- 3) Push insert through wiper body with small cone of wiper body facing up. Place insert retainer over insert and align the holes on the insert and insert retainer. Secure assembly with four self-tapping screws.
- 4) Follower is to be inserted into drum (with insert side up) against the surface of the lubricant.
NOTE: Be sure to remove follower when drum is empty.
- 5) Insert pump into lubricant drum.
 - a) Guide end of pump tube into the follower insert.
 - b) Lower pump tube into lubricant drum until drum cover rests on top bead of drum. Insert the three adjusting screws into the drum cover and tighten securely to hold the pump to the drum.
- 6) Clamp lubrigun to dolly truck.
 - a) Set drum over lugs.
 - b) Loosen clamp screws.
 - c) Adjust bracket to clamp drum
 - d) Clamp adjustable bracket to angle clip on drum cover. Tighten clamp screws and thumb screw to hold drum.
- 7) Assemble the lubricant delivery hose to the pump outlet body. Connections must be leakproof.
- 8) Replace airmotor cover.
 - a) Place cover over airmotor and position over cover-bottom.
 - b) Replace cover nut on pump stud to hold airmotor cover securely in place.
 - c) Assemble air coupler nipple and adapter through hole in side of airmotor cover and into airmotor. Connection must be leak-proof.
- 9) Attach air coupler to an air hose of sufficient length so that lubrigun can be moved about, with air hose attached, to cover the entire lubrication area. When air coupler is connected to air coupler nipple, lubrigun is ready for operation.

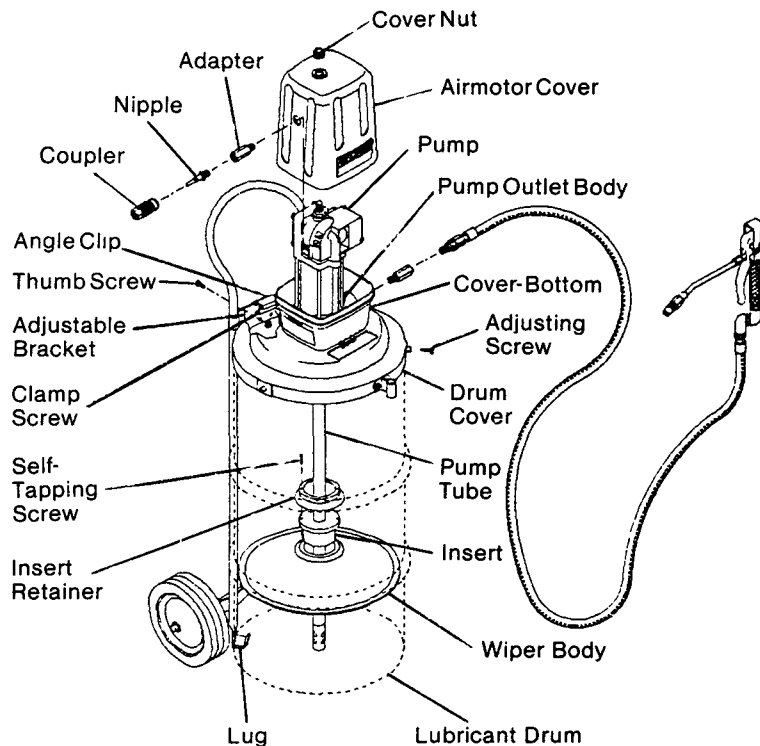

RETAIN THIS INFORMATION FOR FUTURE REFERENCE

When ordering replacement parts, list: Part Number, Description, Model Number, and Series Letter.

LINCOLN provides a Distributor Network that stocks equipment and replacement parts.

[View other fuel transfer and lubrication made by Lincoln on our website.](#)