

Stub pump 3:1

Models 282396 and 282398, series "D"

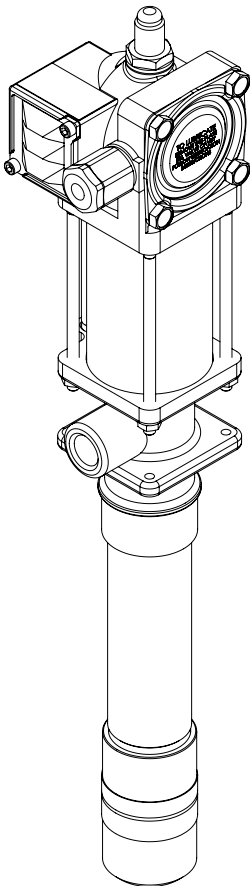

Date of issue	December 2017
Form number	404099
Section	A6
Page	37V

Contents

Safety	2
Explanation of signal words for safety ..	2
Specifications	3
Description	3
Installation	4
Typical system hook-up	4
Pressure relief procedure	5
Operation	5
Before using pump	5
Using pump	5
Lubrication	5
Material restriction prevention	5
Corrosion prevention	5
Service parts	5
To lubricate air valve mechanism	10
Disassembly	11
Troubleshooting	12
Problems	12
Assembly	12
Repair	12
EC Declaration of Conformity	13
Warranty	16

Safety

Read and carefully observe these operating instructions before unpacking and operating pump. Pump must be operated, maintained and repaired exclusively by persons familiar with operating instructions. Local safety regulations regarding installation, operation and maintenance must be followed.

Operate pump only after safety instructions and this service manual are fully understood.

Explanation of signal words for safety

NOTE

Emphasizes useful hints and recommendations as well as information for efficient and trouble-free operation.

⚠ CAUTION

Indicates a dangerous situation that can lead to light personal injury or property damage if precautionary measures are ignored.

⚠ WARNING

Indicates a dangerous situation that could lead to death or serious injury if precautionary measures are ignored.

⚠ DANGER

Indicates a dangerous situation that will lead to death or serious injury if precautionary measures are ignored.

Specifications

Airmotor effective diameter	2 in (50,8 mm)
Stroke	4.8 in (121,9 mm)
Air inlet	1/4 in NPT
Material outlet	1/2 in NPT
Liquid to air pressure ratio	3:1
Delivery output	6 gal/min (22,7 l/min)
Delivery	7.9 in ³ /cycle (129,5 cm ³ /cycle)
Suction head	25 ft (7,62 m) of oil in primed pump
Minimum air pressure	40 psi (2,75 bar)
Maximum air pressure	200 psi (13,8 bar)
Maximum output pressure	600 psi (41,4 bar)
Noise level at 120 psi (9,3 bar)	< 85 dB(A)

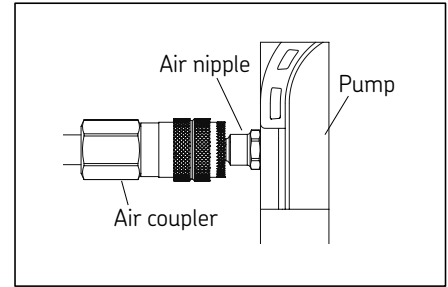

Description

Model 282396 is a stub pump designed to pump low and medium viscosity materials. The pump is self-priming and develops a suction head up to 25 ft (7,63 m) of oil after priming.

⚠ WARNING

Failure to heed the following warnings including misuse, over pressurizing, modifying parts, using incompatible chemicals and fluids, or using worn or damaged parts, may result in equipment damage and/or serious personal injury, fire, explosion, or property damage.

- Do not exceed stated maximum working pressure of pump or of lowest rated component in system.
- Do not alter or modify any part of equipment.
- Do not operate equipment with combustible gas.
- Do not attempt to repair or disassemble equipment while system is pressurized.
- Make sure all fluid connections are securely tightened before using equipment.
- Always read and follow fluid manufacturer's recommendations regarding fluid compatibility, and use of protective clothing and equipment.
- Check all equipment regularly and repair or replace worn or damaged parts immediately.
- Never point dispensing valve at any part of body or at another person.
- Never try to stop or deflect material from dispensing valve or leading connection or component with hand or body.
- Always check equipment for proper operation before each use, making sure safety devices are in place and operating properly.
- Always follow pressure relief procedure after shutting off pump, when checking or servicing any part of system and when installing, cleaning or changing any part of system.

NOTE

Systems that dispense fluids under pressure need to be protected with thermal relief kit. Kit will safely limit pressures caused by thermal expansion.
Contact local Lincoln distributor and refer to service page 423260 for more details.
Failure to include thermal relief protection may cause damage not covered under Lincoln's warranty policy.

⚠ WARNING

Do not flush pump with solvents without pump being grounded.
Splashing or static sparking when flushing pump with solvents can cause explosion.
Always hold metal part of dispensing valve firmly to side of grounded metal pail and operate pump at lowest possible fluid pressure.
Failure to comply may result in death or serious injury.

Installation

Typical bulk tank and drum system hookups are shown and described as follows only as a guide in selecting and installing a system. Contact a Lincoln factory representative for assistance in designing a system for a specific requirement.

Typical system hookup

Determine the tank or drum system for your requirement (→ fig. 1).

Obtain an air line filter/regulator/lubricator to use with the inlet air supply and the correct sized air and fluid lines/hoses with any required reducers, connectors and accessories (→ fig. 2).

Clean/flush the supply reducers, connectors and accessories with mineral spirits or oil based solvent to purge any contaminants such as dirt, moisture, or metal shavings that could damage the pump or system components. Blow dry with air.

Clean/flush pump with mineral spirits or oil based solvents If necessary.

Assemble cleaned pump and supply line together with any required accessory (low level cut-off).

Mount assembled pump to tank or drum.

Connect material output line/hose to pump.

Connect air regulator to pump.

Make sure all connections are securely tightened.

NOTE

Pump was tested in lightweight oil and was left in to prevent corrosion.
Flush pump before connecting to system to prevent possible contamination of grease being pumped.

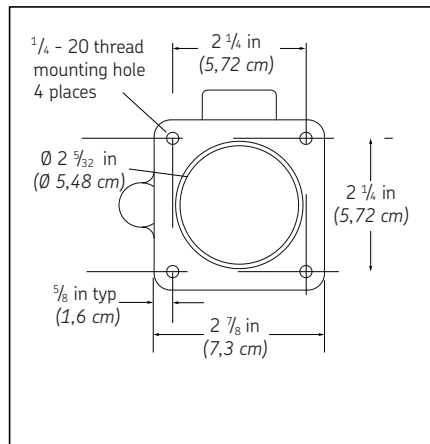

Pressure relief procedure

Always perform procedure when pump is shut off and before checking, servicing, installing, cleaning or repairing any part of system. Perform the following procedure:

- Disconnect air supply to pump
- Point dispensing valve away from yourself and others.
- Open dispensing valve into appropriate container until pressure is relieved.

If above procedure does not relieve pressure, dispensing valve or hose may be restricted. To relieve pressure, very slowly loosen hose end coupling. Then loosen completely and clear dispensing valve and/or hose.

Operation

Before using pump

Prior to operation or maintenance a visual inspection shall be made. Check pump system for leaks, worn or missing parts.

Any pump that appears to be damaged in any way, is badly worn or operates abnormally shall be removed from use until repairs are made. Contact factory authorized service center for repairs.

If overpressurizing of equipment is believed to have occurred, contact factory authorized service center for inspection of pump.

Annual inspection by factory authorized service center is recommended.

⚠ WARNING

To prevent personal injury, perform *Pressure relief procedure* before and after operating pump.

Using pump

- 1 To start pump, turn on main air supply.
- 2 Slowly open air regulator.
- 3 Regulate air pressure from 20-40 psi and throttle to prime pump.
- 4 Open dispensing valve to allow air to be purged from system. Allow pump to cycle until fluid without air pockets flows from dispensing valve, then close dispensing valve.
- 5 After pump is primed, adjust air pressure to achieve smooth flow of fluid from dispensing valve.

NOTE

Do not allow pump to operate when out of material. Pump will accelerate quickly and run too fast,

Failure to comply will result in costly damage to pump.

- 6 If pump accelerates quickly or is running too fast, stop it immediately. Check fluid supply and refill it if necessary.
- 7 Prime pump to remove all air from system, or flush pump and relieve pressure.
- 8 In circulating system, pump runs continuously and slows down or speeds up as supply demands, until air supply is shut off. In direct supply system, with adequate air pressure supplied to motor, pump starts when gun or dispensing valve is opened and stalls against pressure when it is closed.
- 9 Use air regulator to control pump speed and fluid pressure. Always use lowest pressure required to achieve desired results. Higher pressures will cause pump packings to wear prematurely.

Lubrication

Air line filter/regulator/lubricator is recommended for use with pump to remove harmful dirt and moisture from compressor air supply and to provide automatic air motor lubrication. If air line lubricator is not used, the following procedure should be performed daily:

- Disconnect air coupler from air fitting.
- Fill air coupler with NO. 10 SAE motor oil and reconnect to air fitting.
- Operate pump to distribute lubricant.

Material restriction prevention

Flush system as required with compatible solvent to prevent material build up when pumping material that dries or hardens.

Corrosion prevention

To prevent water or air corrosion, never leave pump filled with water or air. Flush pump first with compatible solvent and then again with mineral spirits or oil-based solvent.

⚠ WARNING

To reduce risk of injury from splashing or static sparking when flushing pump with solvents, always hold metal part of dispensing valve firmly to side of grounded metal pail and operate pump at lowest possible fluid pressure.

Service parts

Contact nearest authorized Lincoln Service Center for service parts and repair.

Typical installation

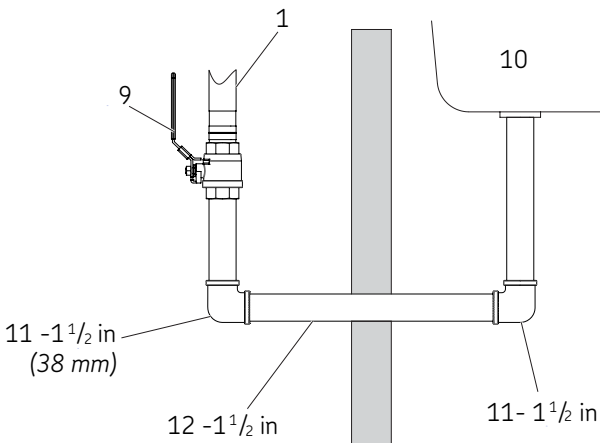
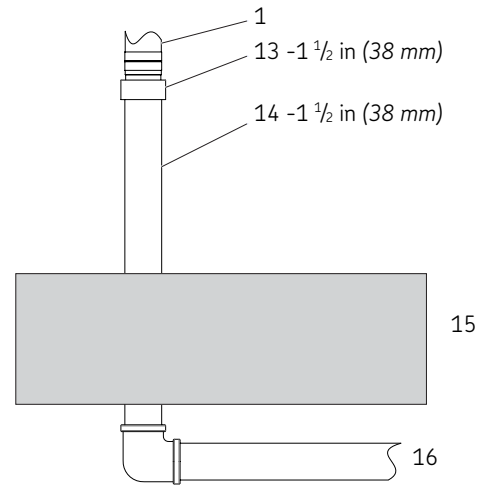
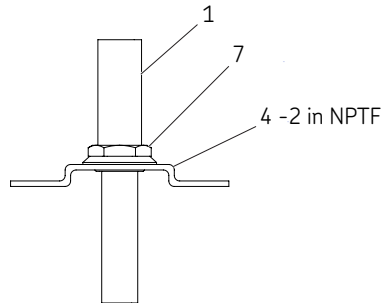
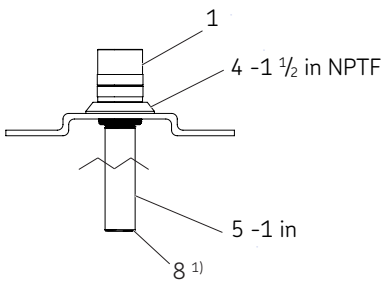
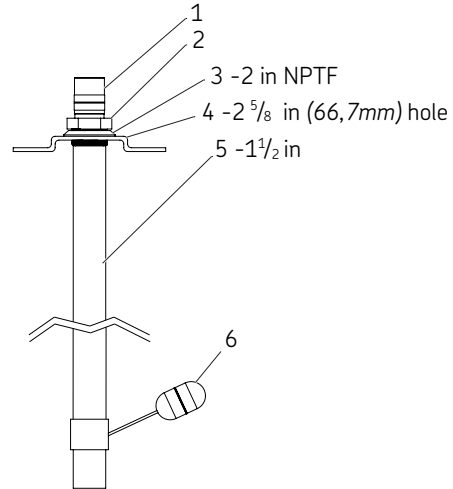
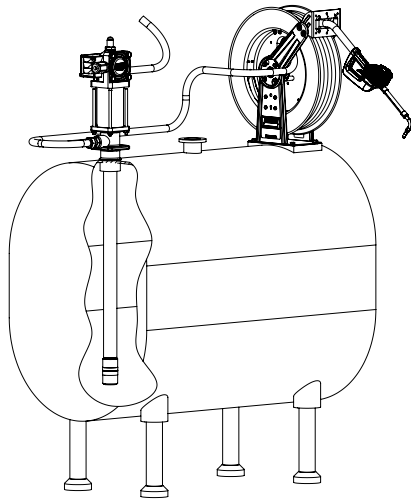

Item	Description
1	Pump
2	Double tapped bushing
3	Welded bung
4	Bulk tank
5	Suction pipe
6	82439 Low level cut-off kit
7	84538 bung bushing assembly
8	Inlet screen
9	Shut off valve
10	Above ground reservoir
11	Elbow
12	Pipe
13	Pipe coupling
14	Stand pipe
15	Concrete floor
16	To underground tank

Note: When pumping from a bulk tank, use a 82439 low level cutoff to maintain prime and prevent air from being pumped through the meter when the tank is empty.
 1) Installed at the end of the intake manifold.

Accessories (must be purchased separately)

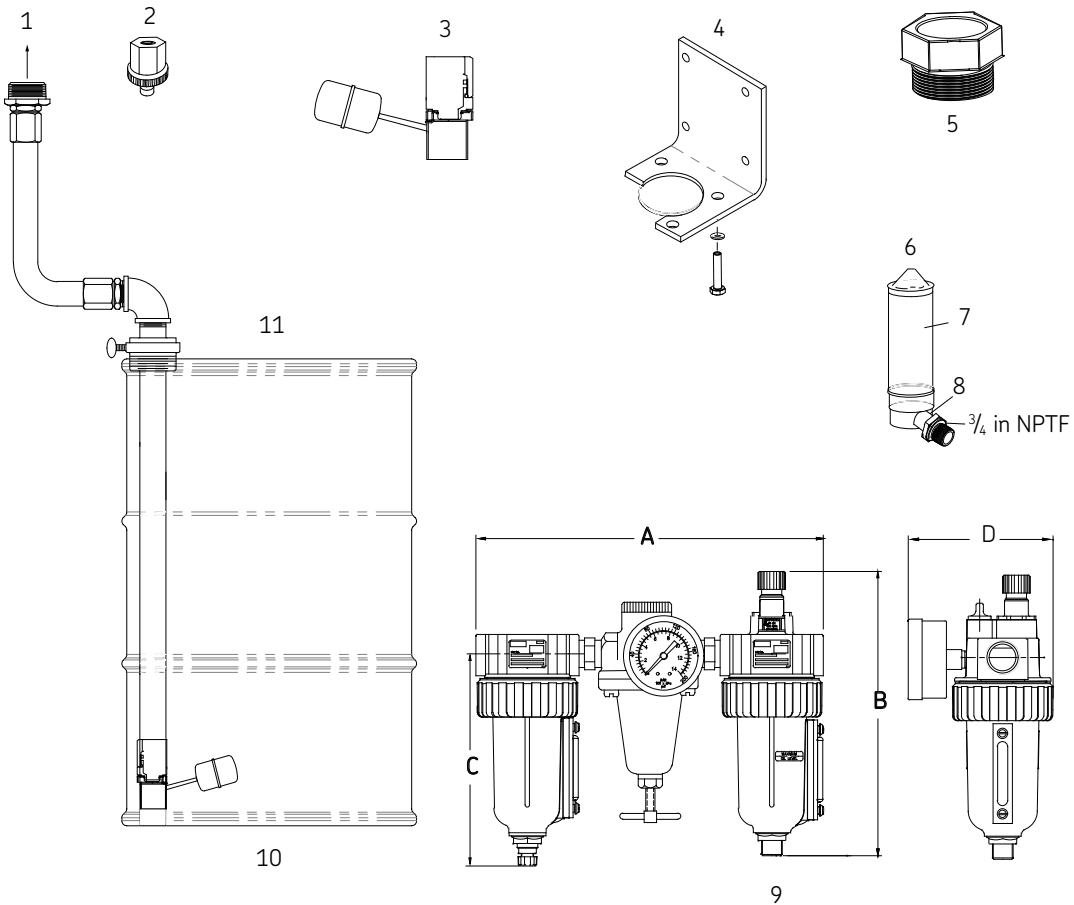

Item	Description
1	To pump
2	M84765 (1 in NPT) foot valve
3	Model 84946 (1 in NPT) and 82439 (1 1/2 in NPT) low level cut-off
4	Model 84940 wall mount bracket kit
5	Model 84538 (2 in NPTF) bung bushing assembly
6	Model 84600 flow compensator kit
7	82014 flow compensator
8	13252 adapter
9	Filter-regulator and gauge-lubricator
10	Low level cutoff is not part of 84945 and 84946. Must be ordered separately.
11	Model 84945 suction kit. For 16 or 55 gallon drums.

Filter-regulator and gauge-lubricator

Model	Pipe size	A	B	C	D	Weight
83387-4	1/4 in (6,35 mm)	8 3/4 in (222,25 mm)	7 5/8 in (193,64 mm)	5 3/8 in (136,53 mm)	4 1/8 in (104,78 mm)	5.5 lbs (2,49 kg)
83387-6	3/8 in (9,53 mm)	8 3/4 in (222,25 mm)	7 5/8 in (193,64 mm)	5 3/8 in (136,53 mm)	4 1/8 in (104,78 mm)	5.5 lbs (2,49 kg)
83387-8	1/2 in (12,7 mm)	10 3/4 in (273,05 mm)	8 1/8 in (206,38 mm)	5 3/4 in (146,05 mm)	4 3/4 in (120,65 mm)	8.5 lbs (3,86 kg)

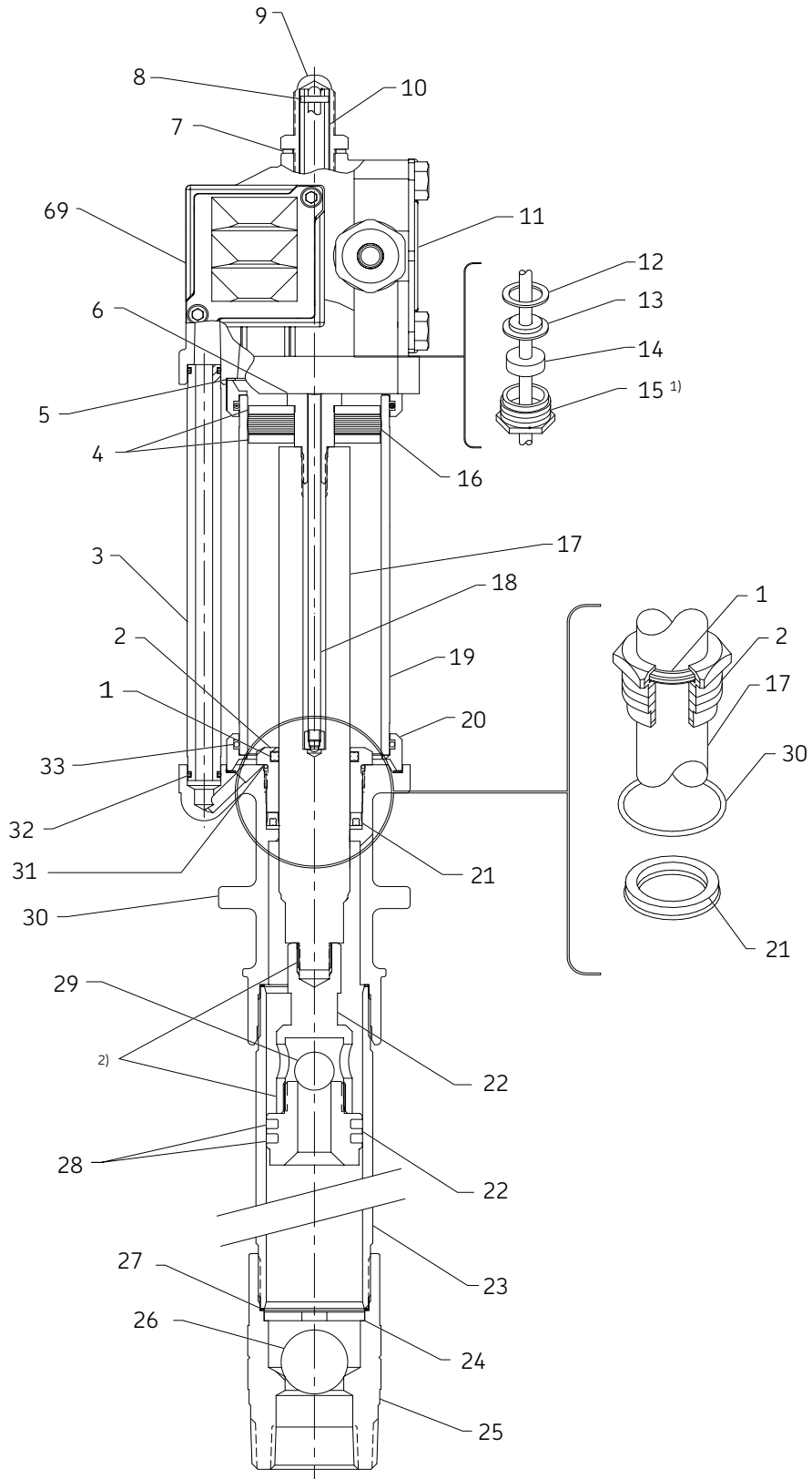

¹⁾ Torque to 10 to 15 ft.lbf (13 to 20 Nm).
²⁾ Use Loctite 510 gasket eliminator on threads

Service parts

Item	Description	Part number	Quantity	Item	Description	Part number	Quantity
1	Quad-ring	245428 ¹⁾	1	37	Warning plate	69578	1
2	Gland packing nut	245426	1	38	Air nipple	11659	1
3	Air passage tube	62383	1	39	Valve gasket	38162 ⁴⁾	1
4	Air piston washer	246499	2	40	Slide and seat kit	83063	1
5	Gasket	33014 ^{1) 2)}	2	41	Spring	56038 ⁴⁾	2
6	Piston bolt	245424	1	42	Steel ball	69102	2
7	Valve cap gasket	30011 ¹⁾	1	43	Spring	55138 ⁴⁾	4
8	Trip rod pin	11472 ¹⁾	1	44	Valve seat screw	236870	4
9	Valve cap	11470	1	45	Trip shoe	11475	1
10	Trip collar	11471	1	46	Screw	236868	4
11	Head assembly	246549	1	47	Cover	236286	1
12	Gasket	33039 ^{1) 2)}	1	48	O-ring (neoprene)	34158 ¹⁾	1
13	Washer	246500 ¹⁾	1	49	Toggle assembly	913315	1
14	Packing (nitrile)	236835 ^{1) 2)}	1	50	Trip sleeve	11947	1
15	Trip rod packing nut	245425 ²⁾	1	51	Valve guide plate	45605	1
16	Air piston packing	261078	1	52	Nut	51009	4
17	Piston rod	241510	1	53	Tie rod	241512	4
18	Trip rod	91528	1	54	Packing nut gasket	30003 ¹⁾	1
19	Air cylinder	246496	1	55	Packing nut gasket	11904	1
20	Cylinder ring	246497	2	56	Packing washer	48237	1
21	U-cup	245427 ¹⁾	1	57	Packing (nitrile)	34110 ¹⁾	1
22	Piston replacement kit	230001	1	58	Packing cap	11905	1
23	Pump tube	241511	1	59	Air hose	72024	1
24	Ball stop	241518	1	60	Coupler	815	1
25	Foot valve body	241517	1	61	Adapter	11348	1
26	Steel ball	66203	1	62	Knurled locknut	11478	1
27	Pump tube gasket	241516	2	63	Pump cover (top and bottom)	85935	1
28	Packing (nitrile)	261077 ^{1) 3)}	2	64	Bare pump assembly	282396	1
29	Connecting rod	230004 ^{1) 3)}	1	65	Adapter	241584	1
30	Outlet casting	245401	1	66	Lubricant hose	73024	1
31	O-ring	245429 ¹⁾	1	67	Hex bolt	50060	4
32	O-ring (nitrile)	34368 ¹⁾	2	68	Bushing assembly	84538	1
33	O-Ring	34420 ¹⁾	2	Not shown	Piston seat	230002 ^{1) 3)}	1
34	Screw	236869 ²⁾	4	Not shown	Piston	230003 ^{1) 3)}	1
35	Muffler cover	236615 ²⁾	1	69	Air valve casting	237562 ²⁾	1
36	Muffler	236833 ²⁾	1				

¹⁾ Included in 230015 repair kit.

²⁾ Included in 237563 repair kit.

³⁾ Included in 230001 piston replacement kit.

⁴⁾ Included in 83063 valve seat assembly.

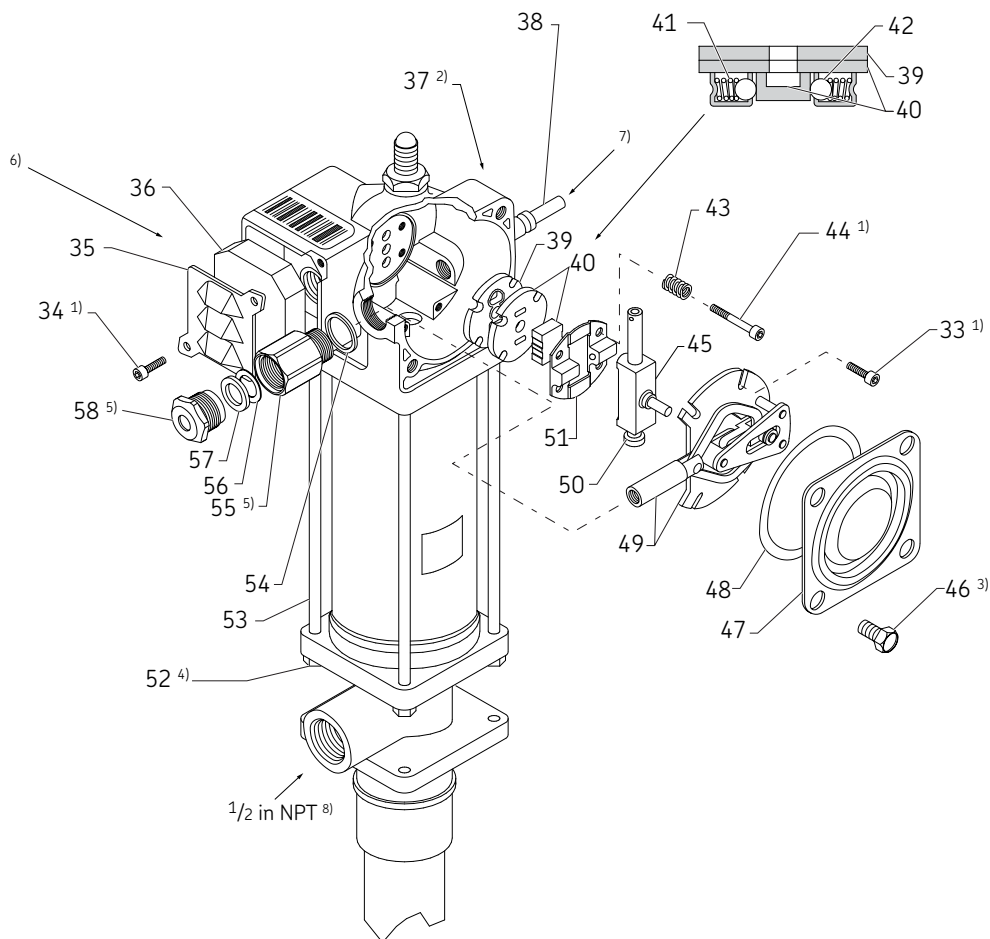

- 1) Tighten to 30-40 in.lbf (3,3-4,5 Nm) of torque.
- 2) Affixed below air inlet
- 3) Tighten to 90-100 in.lbf. (10-11,2 Nm) of torque.
- 4) Tighten to 50-65 in.lbf. (5,6-7,3 Nm) of torque.
- 5) Tighten to 20-25 in.lbf. (2,7-3,3 Nm) of torque.
- 6) Air exhaust port
- 7) Air inlet
- 8) Lubricant outlet

Mounting hole dimensions

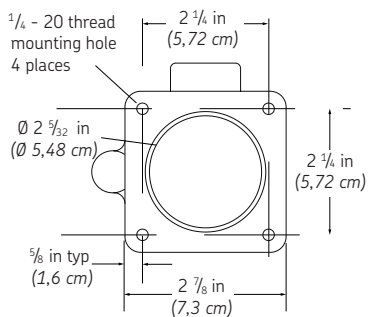

To lubricate air valve mechanism

- 1 Disconnect air to pump.
- 2 Perform pressure relief procedure.
- 3 Remove four cover screws, cover plate and cover plate gasket.
- 4 Pack grease behind toggle plate. Use approximately 1 1/2 oz. of N.L.G.I. No 1 (light grade) water repellent grease 220, sp2.
- 5 If toggle plate has been removed from air valve casting, pack cavity with grease before replacing toggle plate.

- 6 Replace cover plate gasket, cover plate and cover screws. Tighten to prevent air leaks.
- 7 Periodic inspection of parts at least once a year is advised.

NOTE

Start fasteners by hand to avoid stripping threads when reassembling.

Model 282398

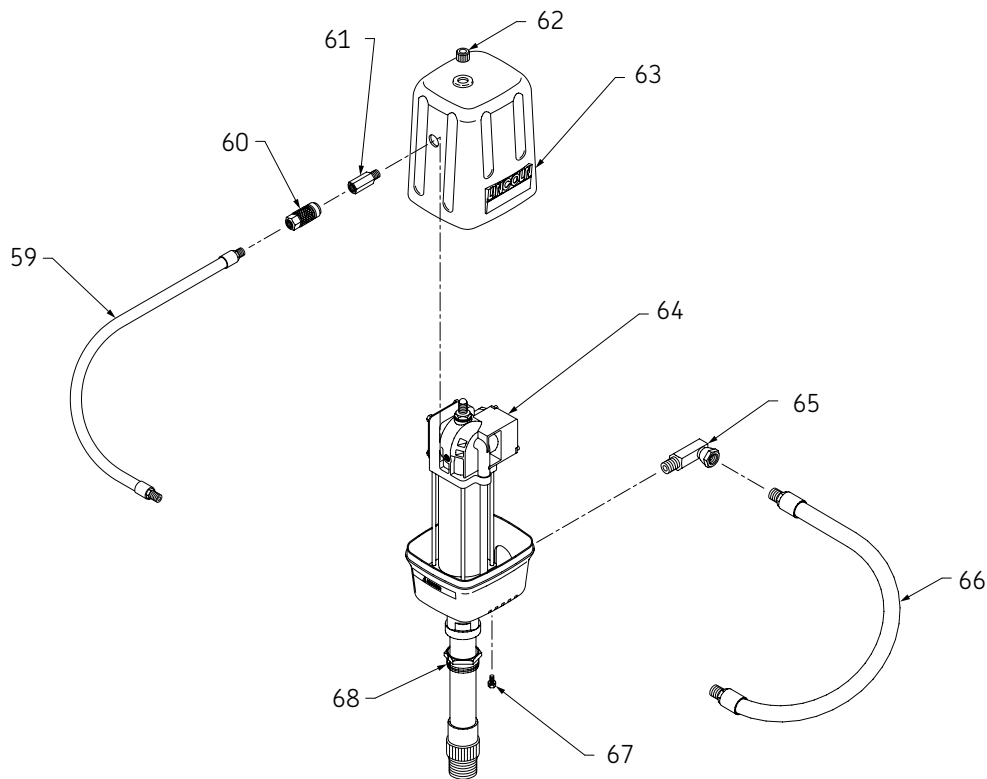

Disassembly

⚠ WARNING

Do not disassemble or assemble pump with pressure applied to pump or system. Relieve all pressure from system before and after use of pump. Failure to comply may result in death or serious injury.

NOTE

If complete disassembly is required, order repair kit and replace **all** gaskets, o-rings and packings.

- 1 Remove valve cap (9), trip rod pin (8) and trip collar (10).
- 2 Remove four tie nuts (52) from tie rods (53).
- 3 Unscrew trip sleeve (50) from trip rod (18) and lift air valve casting (not shown) off of air cylinder (19).
- 4 Remove packing nut (55) and packing cap (58) from air valve casting. Remove packing (57) and packing washer (56).
- 5 Remove four screws (46) and cover (47) with O-ring (48).
- 6 Remove four screws (34), toggle plate (49), trip shoe (45) and trip sleeve (50).
- 7 Remove four valve seat screws (44), four springs (43), valve guide plate (51) with two springs (41), two balls (42) and valve slide and seat kit (40) with gasket (39).
- 8 Unscrew trip rod packing nut (15) from air valve casting and remove all packing and gaskets.
- 9 Unscrew foot valve body (25) and pump tube (23) from outlet casting (30).
- 10 Remove air cylinder (19) and air passage tube (3) from outlet casting.
- 11 Place wrench on piston (not shown) and piston connector (not shown). Remove piston (not shown) with two packings (28) and ball check (29).
- 12 Place wrench on piston bolt (6) and piston rod (17) and remove piston bolt (6), piston packing (16), two washers (4) and trip rod (18).
- 13 Unscrew gland packing nut (2) from outlet casting and remove all gland seal parts.

Troubleshooting

If the following procedures do not correct problem, contact factory authorized service center. When submitting equipment to be repaired, be sure to state nature of problem and indicate if repair cost estimate is required.

Problems

Airmotor does not operate.

- Check air supply to pump.
- Check trip rod pin (8), trip rod (18) and toggle assembly (49) for break-age or loose parts.

Air seepage from air exhaust while pump is not operating

- Check valve slide and seat kit (40) and gasket (39), trip rod packing (14) and washer (13). Replace if necessary.

Loss of pressure, volume or continuous operation of pump when not in normal use.

- Clean piston seat and ball foot valve.
- If worn or damaged, replace piston (not shown), ball check (29) and piston packings (28).
- Check inside diameter of pump tube (23). If scored, replace pump tube.

Excessive amount of air in lubricant or excessive amount of lubricant coming from air exhaust.

- Replace U-cup (21), -ring (31) and Quad-ring (1).

Assembly

To reassemble, perform *Disassembly* procedures in reverse.

Repair

Repair is limited to replacement of listed service parts. Special procedures and tools are required. Contact Lincoln customer service, 5148 N. Hanley, St. Louis, MO 63134, (314) 679-4300 for nearest authorized service center.

When ordering replacement parts, list part number, description, model number and series letter.

NOTE

Some lubricant exhausts with air normally.