

A WELDER FOR ALL SEASONS

Ranger® 305 G and Ranger® 305 G EFI



Shown:
Ranger® 305 G (K1726-5) and
Ranger® 305 G EFI (K3928-1)

KEY FEATURES

Make the Ranger® 305 G your portable welding station – general stick and downhill pipe, Touch Start TIG®, MIG and flux-cored wire capability. Choose the Ranger® 305 G EFI (electronic fuel injection) for easier starts in cold weather and lower fuel consumption, with no choke starting required. The 9,500 watt continuous single-phase AC generator powers motors starting, tools and inverter welders for extended range and process capability.

- Digital weld meters monitor actual welding output
- 12-gallon fuel capacity allows for extended operation
- Electric fuel pump helps avoid vapor lock during high-altitude operation

Processes »

Stick, TIG, MIG, Flux-Cored

Output »



Input »



Product Number »

K1726-5 Ranger® 305 G
K2353-2 Ranger® 305 G One-Pak®
K3928-1 Ranger® 305 G EFI

FEATURES

- » **Kohler® Gasoline Engine Choices**
 - 23 HP carburetor
 - 25 HP EFI (Electronic Fuel Injection) for easier starts in cold weather and lower fuel use!
 - Both engines have electric fuel pump to avoid vapor lock at high altitude operation.
- » **Multi-Process Welding**
 - Excellent DC multi-process welding for general purpose stick, downhill pipe (stick), TIG, cored-wire and MIG (CO₂ and mixed gas).
 - Only compact gasoline welder in North America rated at 29V for 300 amps of stick or CV welding.
 - CV wire welding with up to 5/64 in. (2.0 mm) diameter electrodes.
- » **Digital Weld Meters**
 - Digital weld meters for amps and volts makes it easy to precisely pre-set your procedures and monitor actual welding output.
- » **Superior Arc Performance**
 - Lincoln Electric  Chopper Technology® – provides easy starts, a smooth arc, low spatter and optimal bead appearance.
- » **Peak Single-Phase AC Generator Power for Motor Starting**
 - 10,500 watts peak; 12,000 for EFI.
 - 9,500 watts continuous for high capacity needs such as a back-up generator, powering a Lincoln Electric Invertec® inverter welder. Also use for lights, a grinder or other power tools.
 - AC generator voltage is constant at 120V or 240V at any weld dial setting.
- » **Skewed Rotor Design**
 - Skewed rotor design provides AC power suitable for operating Lincoln Electric inverter power sources. Lincoln Electric was the first in the welding industry with this feature.
- » **Rugged Reliability**
 - Welding and AC Generator Outputs rated at 104°F (40°C).

PERFORMANCE

Welding Performance

- Lincoln Electric  Chopper Technology®.
 - Easy Starts.
 - Smooth Arc.
 - Low Spatter.
 - Optimal Bead Appearance.
- CC-stick mode is optimized for general purpose stick using E7018 low hydrogen electrodes.
- Downhill pipe welding mode is excellent for cellulosic electrodes, such as Lincoln Electric Fleetweld® 5P+™. This mode delivers fast travel speeds, especially on fill passes.
- Arc force control provides a soft or more forceful digging arc in CC-stick or downhill pipe mode and inductance/pinch control in CV wire mode.
- Built-in “hot” start for easier starts and restrikes minimizing the electrode “sticking” to the work.
- Touch Start TIG® (DC) - lift tungsten to start the arc. No high frequency required. Avoids tungsten contamination in the weld. Voltage sensing output stops the arc when the torch is lifted at the end of the weld.
- Arc gouging with up to 3/16 in. (4.8 mm) carbons.

AC Generator Performance

- Up to 40 amps at 240V from the 120V/240V receptacle with weather resistant cover. Circuit breaker protection.
- Two 120V 20 Amp duplex receptacles with weather resistant covers. Circuit breaker protection. Will operate up to 9 in. grinder.
- Nominal 120V and 240V AC generator voltage is independent of any weld dial setting. This is done with one generator system (rotor/stator) using Lincoln Electric  Chopper Technology®, avoiding the complexity of two generator (rotor/stator) systems.

SIMULTANEOUS WELDING AND POWER LOADS

Welding Output (Amps)	Continuous Power (Watts)
300	0
250	2,300
200	4,200
150	5,600
100	7,100
0	9,500

FEATURES

- Simple Controls – Keep training time to a minimum with the straightforward control panel of the Lincoln Electric Ranger 305 G. The flip-down control panel door keeps less frequently used controls out of the way.
- Single, full-range output control dial. No confusion with taps and controls!
- 4 welding modes: CC-Stick, Downhill Pipe, CV-Wire, and Touch Start TIG®.
- Dual digital output meters for presetting weld amps for stick, TIG or downhill pipe modes, or voltage for CV wire mode. Also displays actual outputs while welding. Memory feature holds output readings for 7 seconds after welding stops for viewing by the operator.
- Output at welding terminals controlled by electronic contactor. Can be switched to “On”, or to “Remotely Controlled.”
- Remote output control is auto-activated when plugged into a 6-pin connector. For the CC-stick, downhill pipe and Touch Start TIG® modes, the machine output dial becomes a maximum current limit for more fine tuning with the remote control dial or Amptrol™.
- Compatible with many Lincoln Electric wire feeders including the LN-25 Ironworker®, Activ8®, LF-72, LF-74, LN-7 GMA, LN-742, LN-8, wire feeders and Magnum® SG Gun.
- Wire feed voltmeter switch matches polarity of wire feeder voltmeter to polarity of electrode.
- Top-of-the-line Kohler® engine choices:
 - 23 HP CH730 OHV Command® with carburetor.
 - 25 HP ECH740 OHV Command® with EFI (Electronic Fuel Injection). Choke starting not needed.
- 12 gallon fuel capacity allows you to run an extended day.
- Fully enclosed case for equipment protection and low noise. Noise at rated load:
 - 101.3 dB sound power [Lwa]
 - 76.7 dBA sound level at 23 ft. [7 m]
- Electric fuel pump avoids vapor lock. Assures consistent fuel delivery in locations having a combination of high altitude, warm ambient temperatures, and high anti-pollution additives in gasoline.
- Combination electric fuel gauge and engine hour meter located on control panel. Easily check both fuel level and hours of operation. Fuel gauge helps you virtually eliminate running low on fuel during critical jobs. Hour meter helps plan for scheduled engine maintenance.



Fuel
Hours

- Large top fuel filler neck is easily accessed for refueling.
- Electric start.
- Oil drain valve [no tools required] with removable extension tube.
- Convenient truck or trailer mounting with front and rear holes in base.

KEY CONTROLS

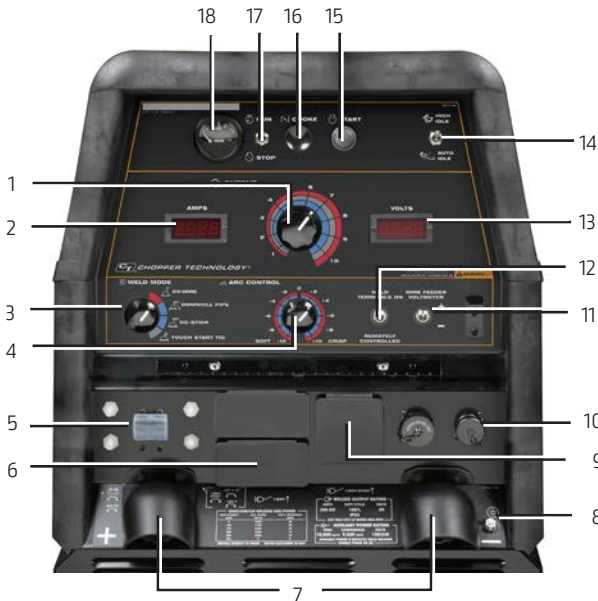

1. Output Control Dial
2. Digital Weld Output Ammeter
3. Weld Mode Switch
4. Arc Force & Inductance/Pinch Control Dial
5. Circuit Breakers
6. 120 Volt AC Receptacles (NEMA 5-20R)
7. Output Stud Covers
8. Ground Stud
9. 120/240 Volt AC Full KVA Receptacle (NEMA 14-50R)
10. 6-Pin Remote Control & 14-Pin Feeder Connectors
11. Wire Feeder Voltmeter Polarity Switch
12. Welding Terminals Control Switch
13. Digital Weld Output Voltmeter
14. Idler Control Switch
15. Pushbutton Start Switch
16. Engine Choke Control (not needed with EFI)
17. Run/Stop Switch
18. Electric Fuel Gauge and Engine Hour Meter

QUALITY AND RELIABILITY

- Printed circuit boards are environmentally-shielded using Lincoln Electric's engineered potting and protective frame trays.
- Oil dip stick, filters, spark plugs, etc. are easily accessed with left, right and top engine doors. Left and right doors are removable for service.
- Adjust exhaust direction with top-mounted 360° rotatable exhaust muffler. Muffler made from aluminized steel for longer life.
- Attractive red and black powder paint finish offers increased durability with added protection from rust and corrosion. Also ultraviolet resistant to better retain color and gloss.
- Longer engine life, reduced noise emissions and greater fuel economy with automatic engine idler.
- Conveniently located engine maintenance label under top engine door.
- Automatic engine shutdown protection for low oil pressure.
- Reliable start-up with Group 58 battery with 435 cold cranking amps.

- Easy access battery cover.



- Optional K1690-1 GFCI (Ground Fault Circuit Interrupter) Kit available for additional protection from electrical shock.
- Dependability and long life aided by all-copper windings in rotor and stator with high quality insulation.
- Approved by Canadian Standards Association (CSA).
- Manufactured under a quality system certified to ISO 9001 requirements and ISO 14001 environmental standards.
- Three year Lincoln Electric warranty (parts and labor) on welder (engine is warranted separately by the manufacturer).



Make the Ranger 305 G your portable welding station – general stick and downhill pipe, Touch Start TIG, MIG, flux-cored and AC generator to power lights, grinders or other power tools.

SYSTEM SELECTION

One-Pak® Welding Package

Order a Lincoln Electric One-Pak® and get everything you need to complete a welding package – all with one order number.

[Package is not assembled.]

Each UNASSEMBLED Package Contains:

- Ranger® 305 G (K1726-5 with electric fuel pump)
- Accessory Kit (K704)
- LN-25 Ironworker® Wire Feeder (K2614-9)
- Gun and Cable (K126-12)
- 5/64 in. (2.0 mm) Innershield® NR®-233 25 lb. (11.3 kg) Spool (ED033039)

Order: K2353-2



Ranger® 305 G



K704 Accessory Kit



K2614-9 LN-25 Ironworker® Wire Feeder



K126-12 Gun and Cable



5/64 in. (2.0 mm) Innershield® NR®-233 25 lb. (11.3 kg) Spool

MACHINE SPECIFICATIONS

Product Name	Ordering Information	Description	CC/Pipe Rated Output Current/Voltage/ Duty Cycle	CV-Rated Output Current/Voltage/ Duty Cycle	Generator AC Power ⁽²⁾⁽³⁾	H x W x L inches (mm)	Weight lbs/(kg)
Ranger® 305 G	K1726-5 With Electric Fuel Pump	300 Amp DC Multi-Process Arc Welder with Lincoln Electric  Chopper Technology 10,500 Watts Peak 9,500 Watts Continuous AC Power	DC Constant Current 305A/29V/100% 20-305A	DC Constant Voltage ⁽¹⁾ 300A/29V/100%	10,500 Watts Peak 12,000 Watts Peak EFI 9,500 Watts Continuous 60 Hz Single Phase	29.9 x 21.5 x 42.3 (759 x 546 x 1073) To top of exhaust tube: 36.2 (920)	510 (231)
Ranger® 305 G EFI	K3928-1 With Electric Fuel Pump		DC Pipe Current 300A/29V/100% 40-300A	14-29 V Single-Dial Continuous Control	Full KVA Receptacle 40A@ 240V 40A@ 120V ea. Branch Circuit ⁽⁴⁾		
Ranger® 305 G EFI Fall Camo	K3928-10 Camo wrapped Roof, Case Sides and Engine Doors		Touch Start TIG® 250A/30V/100% 20-250 A	Wire Feeder Power 42V, 60 Hz, 15 Amps 120V, 60 Hz, 20 Amps	Four 120V Receptacles 20A per Duplex 40A Total ⁽⁴⁾		
			All Models Single Dial Continuous Control 60V DC Max OCV @ 3700 RPM				

⁽¹⁾ DC constant voltage capability provides convenience and added safety when welding in electrically hazardous conditions.

⁽²⁾ When welding, available auxiliary power will be reduced. Output voltage is within +/- 10% at all loads up to rated capacity.

⁽³⁾ 120V will operate either 60 Hz or 50/60 Hz power tools, lights, etc.

⁽⁴⁾ Circuits cannot be wired in parallel to operate the same device.

ENGINE SPECIFICATIONS

Engine Model	Description	Horsepower & Displacement	Ignition	Capacities	Operating Speeds	Fuel Consumption
Kohler® OHV ⁽³⁾ Command® CH730 Gasoline	2 Cylinder, 4 Cycle, OHV, Air-Cooled Gasoline Engine Aluminum Alloy Block with Cast Iron Liners Electric Fuel Pump	23 HP @ 3600 RPM 44 cu in (725 cc)	Electric Start, 12V Group 58 Battery, 435 Cold Cranking Amps, Pushbutton Start Switch, Charging Indicator	FUEL: 12 Gals (45 liters) OIL: 2.0 Qts (1.9 liters)	FULL LOAD 3,500 RPM (300A)	1.7 Gals/Hr 6.5 liters/Hr
					HIGH IDLE 3,700 RPM	1.0 Gals/Hr 3.7 liters/Hr
					LOW IDLE 2,400 RPM	0.4 Gals/Hr 1.5 liters/Hr
Kohler® OHV ⁽³⁾ Command ECH740 Gasoline	2 Cylinder, 4 Cycle, OHV, Air-Cooled Gasoline Engine Aluminum Alloy Block with Cast Iron Liners Electric Fuel Pump Electronic Fuel Injection	25 HP @ 3600 RPM 46 cu in (747 cc)	Electric Start, 12V Group 58 Battery, 435 Cold Cranking Amps, Pushbutton Start Switch, Charging Indicator	FUEL: 12 Gals (45 liters) OIL: 2.0 Qts (1.9 liters)	FULL LOAD 3,500 RPM (300A)	1.5 Gals/Hr 5.8 liters/Hr
					HIGH IDLE 3,700 RPM	0.7 Gals/Hr 2.6 liters/Hr
					LOW IDLE 2,400 RPM	0.4 Gals/Hr 1.5 liters/Hr

⁽³⁾ Kohler® engine warranty is 3 years.

RECOMMENDED ACCESSORIES



GENERAL OPTIONS

Kohler® Tune-Up Kit

For routine engine maintenance. Includes (2) spark plugs, (1) fuel filter, (1) air filter, (1) oil filter, (2) 1 Qt. 10W 30 Oil. Order K3494-1



Factory Undercarriage

For moving by hand on smooth surface floors. Heavy-duty, puncture-resistant (inner tube and sealant) tires and front caster. Convenient steering handle. Order K1770-1



STICK OPTIONS

Accessory Kit

For stick welding. Includes 35 ft. (10.7 m) #2/0 electrode cable, 30 ft. (9.1 m) #2/0 work cable, headshield, work clamp and electrode holder. 400 amp capacity. Order K704



Power Plug Kit

Provides four 120V plugs rated at 20 amps each, and one dual voltage, full KVA plug rated at 120/240V, 50 amps. 120V plug may not be compatible with common household receptacles. Order K802N



Welding Gas Cylinder/ LPG Tank Holder

Holds welding gas cylinder or LPG tank (for products with LPG engine). For LPG: Use one holder for LPG tank and a second holder for welding gas cylinder. Both holders will attach to the K1770-1 undercarriage. Order K1745-1



Accessory Kit

For stick welding. Includes 20 ft. (6.1 m) #6 electrode cable with lug, 15 ft. (4.6 m) #6 work cable with lugs, headshield, filter plate, work clamp, electrode holder and sample pack of mild steel electrode. 150 amp capacity. Order K875



Full-KVA Power Plug

One dual voltage plug rated at 120/240V, 50 amps. NEMA 14-50P. Order T12153-9



Shown with optional K2639-1 Fender & Light Kit

Small Two Wheel Welder Trailer

For heavy-duty road, off-road, plant and yard use. Includes pivoting jack stand, safety chains, and 13 in. (330 mm) wheels. Stiff .120 in. (3.0 mm) welded rectangular steel tube frame construction is phosphate etched and powder coat painted for superior rust and corrosion resistance. Low sway suspension gives outstanding stability with manageable tongue weight. Wheel bearings are packed with high viscosity, high pressure, low washout Lubriplate® grease. Includes a Duo-Hitch™, a 2 in. (51 mm) ball/lunette eye combination hitch. Overall width 60 in. (1524 mm). Overall length 110 in. (2794 mm). Order: K2635-1 Trailer K2639-1 Fender & Light Kit K2640-1 Cable Rack



Full-KVA Adapter Kit

Provides convenient connection of Lincoln Electric equipment having a 240V AC 1-phase plug (NEMA 6-50P) to the full-KVA receptacle on engine-driven welders. Order K1816-1



GFCI Receptacle Kit

Includes one UL approved 120V ground fault circuit interrupter duplex type receptacle and installation instructions. Replaces the factory-installed 120V duplex receptacle. Each receptacle of the GFCI duplex is rated at 20 amps. Maximum total current from the GFCI duplex is limited to 20 amps. Two kits required for all 120V receptacles on the Ranger 305 G and Ranger 305 G EFI. Order K1690-1



Spark Arrestor Kit

Attaches to muffler exhaust tube. Virtually eliminates spark emissions. Order K1898-1



Polarity/Multi-Process Switch

For easy polarity switching. Example: DC-stick root pass on pipe & DC+ stick for hot, fill and cap passes. Also for an easy process change. Example: DC+ stick root pass on pipe & DC- Innershield™ self-shielded flux-cored wire for hot, fill and cap passes. 6 & 14-pin remote connections can be made to this unit. For all Lincoln Electric Chopper Technology® engine-driven welders. Mounts on roof with K2663-1 Docking Kit. Order K2642-1



Canvas Cover

To protect the engine drive when not in use. Made from attractive red canvas material that is flame retardant, mildew resistant and water repellent. Order K886-2



All-Terrain Undercarriage

For moving by hand at construction sites. Maneuvers over obstacles. Heavy-duty puncture-resistant (inner tube and sealant) tires. Order K1737-1



Docking Kit

Secures the K2642-1 Polarity/Multi-Process Switch to the engine-driven welder roof. Release latch permits removal of K2642-1 Polarity/Multi-Process Switch. Made from stainless steel for rust-free operation. For all Lincoln Electric Chopper Technology® engine-driven welders. Order K2663-1



Remote Control Kit

Consists of a control box with choice of two cable lengths. Permits remote adjustment of output. Order K857 for 25 ft. (7.6 m) K857-1 for 100 ft. (30.5 m)



TIG OPTIONS

Pro-Torch™ PTA-26V TIG Torch

Air-cooled 200 amp torch equipped with valve for gas flow control. 25 ft. (7.6 m) length. Order K1783-9



Foot Amptrol™

Varies current while welding for making critical TIG welds and crater filling. Depress pedal to increase current. Depressing pedal fully achieves maximum set current. Fully raising the pedal finishes the weld and starts the afterflow cycle. Includes 25 ft. (7.6 m) control cable. Order K870



Hand Amptrol™

Provides 25 ft. (7.6 m) of remote current control for TIG welding. (6 pin plug connection). Velcro straps secure torch. Order K963-3 (one size fits all Pro-Torch™ TIG torches)



Magnum® Parts Kit for PTA-26V TIG Torch

Provides all the torch accessories you need to start welding. Parts kit provides collets, collet bodies, a back cap, alumina nozzles and tungstens in a variety of sizes, all packaged in an easy to carry reclosable pack. Order KP509



Square Wave™ TIG 200

This 46 lb. (21 kg) TIG and stick welder includes adjustable AC Frequency Control and AC Balance for great results on aluminum, pulse mode and 120V or 230V input power capability. Order K5126-1

RECOMMENDED ACCESSORIES

WIRE FEEDERS



LN-25X/Magnum® PRO Curve™ 045C One-Pak
Includes: LN-25X Feeder with CrossLinc™ Technology (K4267-1); Magnum® PRO Curve™ welding gun Ready-Pak® 15 ft. (4.6 mm) (K2951-2-10-45); Drive Roll Kit .040-.045 in. (1.0-1.2 mm Cored Wire (KP1697-045C)
Order K4100-1



LN-25X/K126 PRO 1/16-5/64C One-Pak
Includes: LN-25X Wire Feeder with CrossLinc™ Technology (K4267-1); K126™ PRO Innershield® 350A FCAW-SS Welding Gun 15 ft. (4.6 m) 1/16-5/64 (K126-12); Drive Roll Kit 5/64 in. (2.0 mm) Solid/Cored Wire (KP1697-5/64); Drive Roll Kit 1/16 in. (1.6 mm) Cored Wire (KP1697-1/16C)
Order K4100-2



Magnum® SG Spool Gun
Hand held semiautomatic wire feeder. Requires SG Control Module
Order K487-25



SG Control Module
The interface between the power source and the spool gun. Provides control of wire speed and gas flow. For use with a spool gun.
Order K488



Input Cable
(For SG Control Module)
For Lincoln Electric engine power sources with 14-pin MS-type connection, separate 115V NEMA receptacles and output stud connections.
Order K691-10



POWER MIG® 180C
Premium compact wire welder with continuous voltage control for MIG and flux-cored welding. 30 to 180 amp output range. Get input power from the AC generator of the engine-driven welder with the K1816-1 Full-KVA Adapter Kit (required). Add the K2532-1 Magnum® 100SG Spool Gun for aluminum MIG welding.
Order K2473-2



Magnum® 100SG Spool Gun
Designed to easily feed 4 in. (102 mm) diameter 1 lb. (0.45 kg) spools of .030 in. (0.8 mm) or .035 in. (0.9 mm) diameter SuperGlaze® aluminum MIG wire. Includes gun, adapter kit, .035 in. (0.9 mm) contact tips (qty. 3), gas nozzle, and 1 lb. (0.45 kg) spool of SuperGlaze® 4043 .035 in. (0.9 mm) MIG wire. Packaged in a convenient carrying case.
Order K3269-1

PLASMA CUTTING



Tomahawk® 1000
Cuts metal using the AC generator power from the engine-driven welder. Requires the T12153-9 Full-KVA Power Plug (1-Phase).
Order K2808-1

PRODUCT SPECIFICATIONS

Product Name	Product Number	Rated Output Current/Voltage/Duty Cycle	Output Range	Engine	Number of Cylinders	HP @ Speed (RPM)	H x W x D in (mm)	Net Weight lb (kg)
Ranger® 305 G	K1726-5	305A DC CC/29V/100% 300A DC CV/29V/100%	20-305A DC 40-300A Pipe 20-250A DC TIG 14-29V CV 10,500 watts peak 12,000 watts peak EFI 9,500 watts continuous	Kohler® OHV Command® CH730 Gasoline Electric Fuel Pump	2	23 @ 3600	29.9 x 21.5 x 42.3 (759 x 546 x 1073) To top of exhaust tube: 36.2 (920)	510 (231)
Ranger® 305 G One-Pak	K2353-2						-	-
Ranger® 305 G EFI	K3928-1			Kohler® OHV Command® ECH740 Gasoline Electric Fuel Pump Electronic Fuel Injection	25 @ 3600	29.9 x 21.5 x 42.3 (759 x 546 x 1073) To top of exhaust tube: 36.2 (920)	510 (231)	
Ranger® 305 G EFI Fall Camo	K3928-10							

