

Power Wave® S500

Processes

Stick, DC TIG, Pulsed DC TIG, MIG, Pulsed MIG, Flux-Cored

Product Number

K2904-1 Power Wave S500
K3187-2 Power Wave S500 Ready-PaK
K3186-2 Power Wave S500 One-PaK

See back for complete specs

Input Voltage

200/208/220/230/380/400/415/460/575/
3/50/60

Input Current @ Rated Output

3 Ph / 40% Duty Cycle: 80/73/41/37/29A
3 Ph / 100% Duty Cycle: 60/54/30/27/21 A

Output Range

5-550 Amps

Rated Output

GMAW: 550A/41.5V/40%
GMAW: 450A/36.5V/100%

Weight/Dimensions (H x W x D)

150 lbs. (68 Kg)

22.5 x 14 x 24.8 in.

(571 x 355 x 630 mm)

Powerful Multi-Process Capability.

The multi-process Power Wave® S500 is packed with Lincoln Electric performance technology for welding on thicker materials. It provides an extremely fast arc response, includes over 65 standard welding waveforms for optimized performance on almost any application and efficiently converts input power to reduce operational costs.

FEATURES

PowerConnect™ Technology

(Patent-Pending) – Automatically adjusts to input power from 200-600V, 50 or 60 Hz, three phase. Welding output remains constant through the entire input voltage range.

Tribrid™ Power Module – Exceptional welding performance with high power factor and efficiency.

CheckPoint™ – A cloud-based system to view or analyze your welding data. Track equipment usage, store weld data, configure fault limits and more.

Standard 115V (10A) AC Duplex Auxiliary Power Receptacle – Features patent-pending Surge Blocker™ Technology to ensure simultaneous welding performance is not compromised by high starting current devices such as grinders (typically requiring 60A or more peak surge current).

Durable Case – IP23 rated to withstand harsh environments.

APPLICATIONS

- ▶ Construction
- ▶ Aerospace
- ▶ Fabrication
- ▶ Automotive
- ▶ Production



Shown: K2904-1
Power Wave S500

RECOMMENDED WIRE FEEDERS

- ▶ Power Feed® 84 Bench and Boom models
- ▶ Power Feed® 25M

WAVEFORM CONTROL TECHNOLOGY® PROCESS CAPABILITIES

- ▶ Pulse
- ▶ Pulse-on-Pulse®
- ▶ Power Mode®
- ▶ RapidArc®
- ▶ Rapid X™ (With STT® Module)
- ▶ Upgradable for additional processes to be developed in the future.

INPUT



OUTPUT



KEY CONTROLS

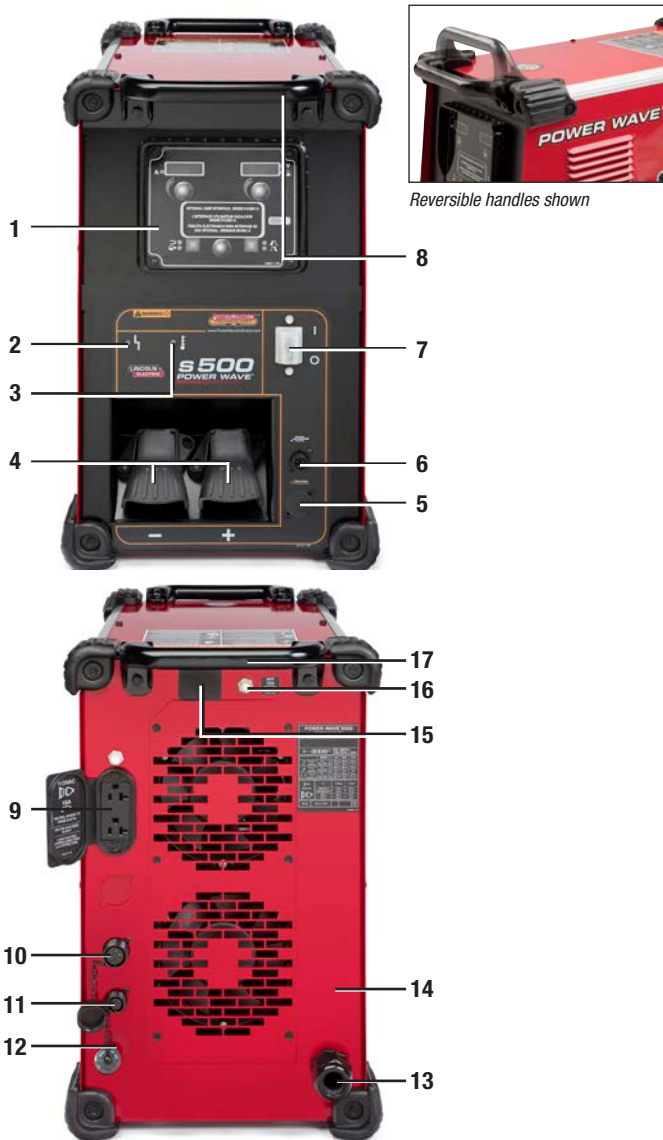

FRONT

1. Optional S-Series User Interface Kit (K3001-2) for Stick, TIG and CV MIG with voltage sensing feeder
2. Status Light
3. Thermal Fault Indicator Light
4. Output Studs
5. Output Control Receptacle Knockout Plate – 12-pin (for optional output control receptacle included with K3001-2 S-Series User Interface Kit)
6. Work Sense Lead Receptacle
7. Main Power Switch
8. Reversible Handles

BACK

9. Standard 115V (10 Amp) AC Duplex Auxiliary Power Receptacle and Circuit Breaker
10. ArcLink® Welding System Component Communication Cable Receptacle
11. Sync Tandem/STT® Receptacle
12. Optional DeviceNet™ Kit (K2827-2)
13. Input Power Cable Connection
14. TIG Solenoid Kit Knockout Plate (for optional TIG solenoid included with K3001-2 S-Series User Interface Kit)
15. Ethernet Cable Receptacle
16. Circuit Breaker (ArcLink®)
17. Reversible Handles

OPTIONAL K3001-2 S-SERIES USER INTERFACE KIT

To tap into the Power Wave® S500 stick, TIG and CV MIG process capability without a Power Feed® series wire feeder, add the K3001-2 User Interface Kit. This optional interface provides full control of welding parameters from the front panel of the power source for stick and TIG processes. When used with a Power Feed® series wire feeder, the feeder is typically used for controlling the system and the K3001-2 User Interface Kit meters can be used for viewing amps and volts. Kit also includes 12-pin Universal Remote Receptacle and TIG Gas Solenoid.

The User Interface Kit allows control over:

- **Volts/Amps Control** – Adjust volts in MIG and flux-cored welding or adjust amperage in stick or TIG welding.
- **Welding Mode** – Select the stick, TIG or CV wire process.
- **Advanced Process Options** – Control pre- and post-weld settings to optimize arc starts and stops.
- **Arc Control** – Adjust arc characteristics to match individual preferences.



WHAT'S INCLUDED

Ready-Pak® Packages are assembled and shipped on one pallet. **One-Pak® Packages** are not assembled. All packages can be ordered using a single Product Number (K#). Welding wire and shielding gas must be ordered separately.

Power Wave® S500/Power Feed® 84 Bench Feeder Ready-Pak®, includes:

- Power Wave® S500 (K2904-1)
- Power Feed® 84 Bench Model (K3328-13)
 - Wire Reel Stand
 - ArcLink®/Linc-Net™ Control Cable with Weld Power Cable - 8 ft. (2.4 m)
- Magnum® PRO Curve™ 400 Gun and Cable Package (K2952-2-10-45)
- .040-.045 (1.0-1.1 mm) Drive Roll Kit (KP1505-045S)
- Work Lead Package (K2149-1)
- Harris® Flowmeter Regulator and Hose (3100211)
- Inverter and Wire Feeder Cart (K3059-4)

Order K3187-2

Power Wave® S500/Power Feed® 84 Bench Feeder One-Pak®, includes:

- Power Wave® S500 (K2904-1)
- Power Feed® 84 Bench Model (K3328-13)
 - Wire Reel Stand
 - ArcLink®/Linc-Net™ Control Cable with Weld Power Cable - 8 ft. (2.4 m)
- Magnum® PRO Curve™ 400 Gun and Cable Package (K2952-2-10-45)
- .040-.045 (1.0-1.1 mm) Drive Roll Kit (KP1505-045S)
- Work Lead Package (K2149-1)
- Harris® Flowmeter Regulator and Hose (3100211)

Order K3186-2



Shown: K3187-1

TECHNOLOGIES



Tribrid™ Power Module

Features PowerConnect™ technology, Planar Transformer™ Technology and 120kHz output to provide exceptional welding performance while still maintaining a high power factor and efficiency.



iARC™ High Speed Digital Controls

iARC™ (Intelligent Architecture for Regulation and Control) digital welding controls are faster, include more RAM, and more memory than the previous generation. It also features 100Mbps Full Duplex Ethernet to support Lincoln Electric's CheckPoint™.



CheckPoint™

CheckPoint, cloud server-based and mobile delivery solutions, is the welding industry's most advanced weld data collection and monitoring tool, allowing fabricators to analyze their welding operations and processes. These tools can provide necessary data for customer ISO, Six Sigma, statistical process control (SPC), quality cost delivery (QCD), overall equipment effectiveness (OEE) and lean manufacturing efforts. CheckPoint is offered at no charge with every Power Wave purchase.



Rugged Reliability

Tested under severe conditions:

- Extreme Temperature Ranges
- Extreme Humidity
- Rain
- Dirt and Dust
- IP23 Rated Performance

RECOMMENDED ACCESSORIES

GENERAL OPTIONS



S-Series User Interface Kit
This kit allows local control of stick, TIG and wire processes from the power source control panel. Includes TIG Solenoid and Remote Control Connector.
Order K3001-2



DeviceNet™ Kit
The kit allows DeviceNet™ connectivity to control the power source. Includes internal harness and 5-pin DeviceNet™ receptacle for mounting on power source back panel.
Order K2827-2



Inverter and Wire Feeder Cart
Rear-wheeled cart with front casters and gas bottle platform. Convenient handles allow for easy cable storage. Small footprint fits through 30 in. (762 mm) door. Not intended for use with double head wire feeders.
Order K3059-4



Dual Cylinder Inverter & Wire Feeder Cart
Rear-wheeled cart with front casters and dual cylinder platform. Convenient handles allow for easy cable storage. Small footprint fits through 30 inch (762 mm) door.
Order K3059-5



Work Lead Package
15 ft. (4.5 m) 4/0 cable with 1/2 in. stud lug and work clamp.
Order K2149-1



Work Voltage Sense Lead Kit
Required to accurately monitor voltage at the arc.
Order K940-25 for 25 ft. (7.6 m)
Order K1811-50 for 50 ft. (15.2 m)
Order K1811-100 (shown) for 100 ft. (30.5 m)

RECOMMENDED ACCESSORIES

GENERAL OPTIONS, CON'T



Deluxe Adjustable Gas Regulator & Hose Kit
Accommodates CO₂, Argon, or Argon-blend gas cylinders. Includes a cylinder pressure gauge, dual scale flow gauge and 4.3 ft. (1.3 m) gas hose.
Order K586-1



Weld Fume Control Solutions
Lincoln Electric offers a wide variety of weld fume control solutions, ranging from portable systems easily wheeled around the shop to shop-wide central systems servicing many dedicated welding stations.
Request Publication MC08-70

STICK OPTIONS



Accessory Kit
Complete kit for stick welding. Includes 30 ft. (9.1 m) electrode cable, 25 ft. (7.6 m) work cable, headshield, work clamp and electrode holder. 150 amps.
Order K704



Shown: Cool Arc 55 S

Cool Arc® 55 Water Cooler
Designed to integrate with Power Wave® S350 and S500 power sources to cool water-cooled welding guns or torches rated up to 500 amps. Recommended for robotic and hand-held MIG, TIG and Plasma cutting operations. 115V/1/60. The 55 S model includes an ArcLink® communication flow sensor that detects water flow to prohibit welding when no flow is present.
Order K3086-1 for Cool Arc 55
Order K3086-2 for Cool Arc 55 S



Remote Output Control with 12-pin Universal Connector
Permits remote adjustment of output. Requires K3001-2 S-Series User Interface Kit.
Order K857-2 for 25 ft. (7.6 m)



12-pin to 6-pin Adapter
Allows older 6-pin remote controls (K870, K963-3, K857) to be used with 12-pin Universal Connection.
Order K2909-1



12-pin to 7-pin Adapter
Allows 7-pin push-pull guns to be used with 12-pin Universal Connection.
Order K2910-1

TIG OPTIONS



PTA-17 150 Amp Air-Cooled TIG Torch
Order K1782-1 for 12.5 ft. (3.8 m) length, 1-cable
Order K1782-3 for 25 ft. (7.6 m) length, 1-cable



PTA-26 200 Amp Air-Cooled TIG Torch
Order K1783-1 for 12.5 ft. (3.8 m) length, 1-cable
Order K1783-3 for 25 ft. (7.6 m) length, 1-cable



Parts Kits
Magnum® Parts Kits provide all the torch accessories you need to start welding. Parts kits provide collets, collet bodies, a back cap, alumina nozzles and tungstens in a variety of sizes, all packaged in an easy to carry reclosable box.
Order KP508 for PTA-17
Order KP509 for PTA-26



Foot Ampctrl™ with 12-pin Universal Connector
Provides 25 ft. (7.6 m) of remote current control for TIG welding. Requires K3001-2 S-Series User Interface Kit.
Order K870-2



Hand Ampctrl™ with 12-pin Universal Connector
Provides 25 ft. (7.6 m) of remote current control for TIG welding. Requires K3001-2 S-Series User Interface Kit.
Order K963-4

WIRE FEEDER OPTIONS



STT® Module
This module allows easy connection and fast digital communication with compatible Power Wave® S-Series power sources, Power Feed® wire feeders, and compatible water coolers. Add STT® capability without having to purchase a second power source.
Order K2902-1 US/Int'l (shown)
Order K2921-1 CE



Power Wave® Advanced Module
Provides multi-process reverse polarity (DC+), straight polarity (DC-), AC, high frequency TIG and STT® functionality. Compatible with Power Wave® S350 and S500.
Order K2912-1



Magnum® PRO AL Air-Cooled & Water-Cooled Push-Pull Guns
The Magnum PRO AL gooseneck style guns are designed to optimize a push-pull welding operation for aluminum. Uses Magnum PRO MIG Gun expendables. Available in 7-pin and 12-pin connections.
Request Publication E12.14



AutoDrive® 19 Controller
Relays wire feed commands from Power Wave® S Series power source to any AutoDrive® Series robotic wire drive for automated welding operation. Not compatible with Power Wave® R-Series power sources.
Order K3004-1



AutoDrive® 19 Tandem Controller
Relays wire feed commands from Power Wave® S-Series power source to any AutoDrive® Series robotic wire drive for automated tandem welding operations.
Order K3171-1

PRODUCT SPECIFICATIONS

Product Name	Product Number	Input Voltage	Input Current @ Rated Output	Rated Output Current/Voltage/Duty Cycle	Output Range	H x W x D inches (mm)	Net Weight lbs. (kg)
Power Wave® S500	K2904-1	200/208/220/230/380/ 400/415/460/575/ 3/50/60	3 Ph / 40% Duty Cycle: 80/73/41/37/29 3 Ph / 100% Duty Cycle: 60/54/30/27/21	GMAW: 550A/41.5V/40% GMAW: 450A/36.5V/100% SMAW: 550A/42V/40% SMAW: 450A/38V/100% GTAW-DC: 550A/32V/40% GTAW-DC: 450A/28V/100%	5-550A	22.5 x 14 x 24.8 (571 x 355 x 630)	150 (68)
Power Wave® S500/ Power Feed® 84 Ready-Pak®	K3187-2						
Power Wave® S500/ Power Feed® 84 One-Pak®	K3186-2						