

# ASSEMBLY AND INSTALLATION INSTRUCTIONS

## JOBMASTER® Rolling Work Bench - Models 40 & 44

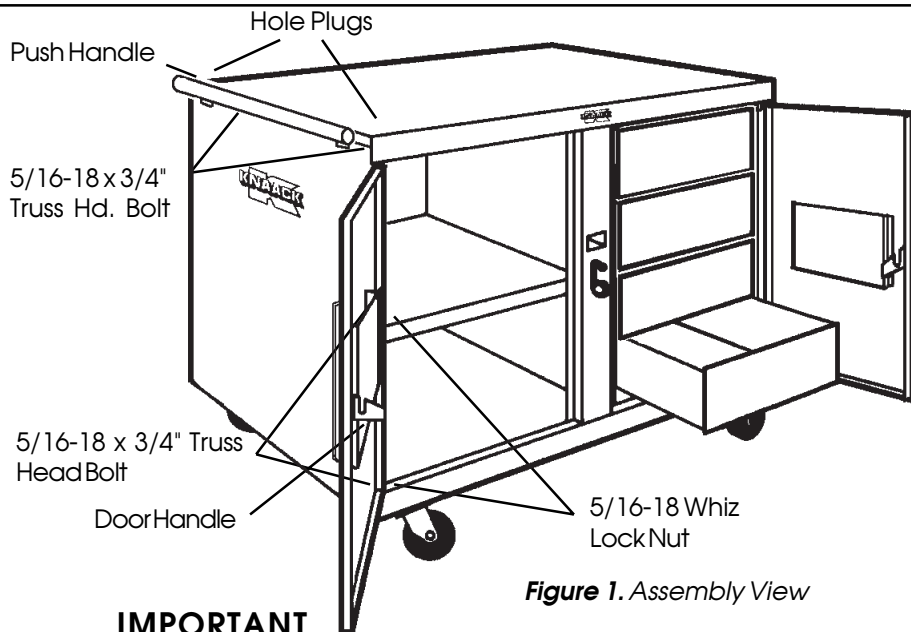

Figure 1. Assembly View

### IMPORTANT BEFORE YOU BEGIN

Read these instructions and warnings completely before installation.

#### CASTER BOLT KIT

Bolt kit #32-0001 is provided with your RWB. Check this bolt kit to be sure the following parts are included:

Quan.	Description
16	5/16-18 X 3/4" Carriage Bolt
16	5/16-18 Whiz Lock Nut
16	1/4" Pushnut

#### HANDLE / LIFT KNOB KIT

- 1 - Push Handle
- 2 - Door Handles
- 6 - 5/16-18 x 3/4" Bolt, Truss hd.
- 4 - 5/16-18 Hex Whiz Nut
- 1 - Lift Knob
- 2 - Hole Plugs

#### PARTS LIST

- Work Bench Cabinet
- Caster Set with bolt kit
- Handle Kit

## ! DANGER

- Do not put fuels, flammables, explosives or hazardous materials inside these products.
- Gasoline, solvents, gun powder or other munitions, dynamite, propane, acetylene or other such products can explode if stored inside these products.
- Use these products ONLY for storing and transporting electric or hand tools and equipment, and other similar materials.
- Failure to follow these warnings or modification or other uses of these products could result in death, serious injury or property damage.

## ! WARNING

Black knob must be latched in the closed position when moving this product, so doors and drawers do not open on inclines, which can cause serious personal injury or property damage.

## CAUTION

Caster Brakes are not suitable for keeping units in place when transporting. Secure by another method. Do not use casters on rough or uneven surfaces. Do not tow caster mounted boxes.

#### TOOLS REQUIRED

- 1/2" Open or Box End Wrench
- 1/2" Socket (3/8" drive)
- 3/8" Medium Extension
- 3/8" Ratchet Wrench
- Screwdriver, common

#### ASSEMBLY INSTRUCTIONS

1. Remove the caster box, handles, and bolt kit from the cabinet. Attach the Door Handles (Figure 1). Insert Hole Plugs in the Push Handle and attach to the end.

#### WATCHMAN® III Lock System

##### IMPORTANT:

Carefully follow the separate instructions (see inside door) which will guide you to a proper lock installation.

#### Caster Set Installation

2. Close the doors and lay the cabinet on its back onto the flattened shipping carton to prevent paint scratches (Figure 2). Mount the Swivel Casters on end you mounted the Push Handle. Insert a Carriage Bolt into a mounting hole, and push a Pushnut onto the bolt to hold it in place (Figure 3). Repeat this for the other three mounting bolts. Place the Caster over the bolts, then fasten

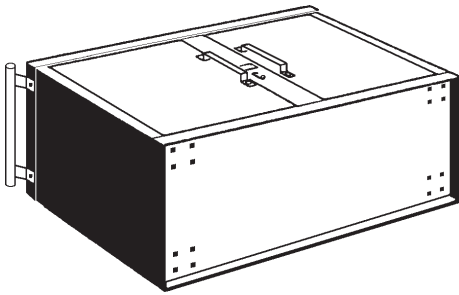

**Figure 2.** Caster Mounting Holes with Whiz Nuts. Repeat this for the remaining Casters.

### Drawer Removal

3. To remove a drawer (Figure 4.), pull the drawer out until it stops. Notice the locking levers located inside the track that is attached to the drawer. Lift the left lever (A)

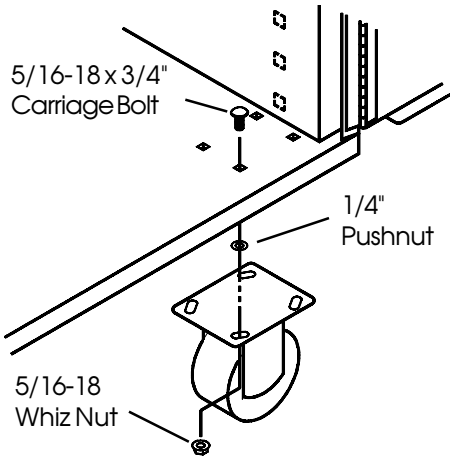

**Figure 3.** Caster Mounting while pressing down on the right lever (B). Pull drawer clear on the slides.

### Drawer Installation

4. When right and left slides are in place, extend fully. Next, push rear pocket on drawer onto rear clip on

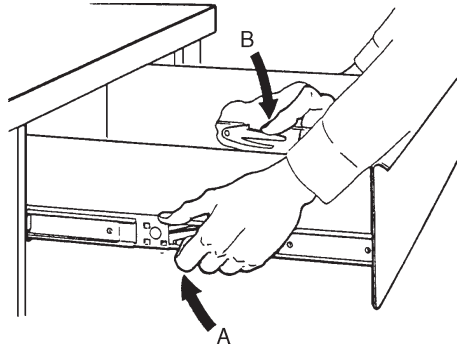
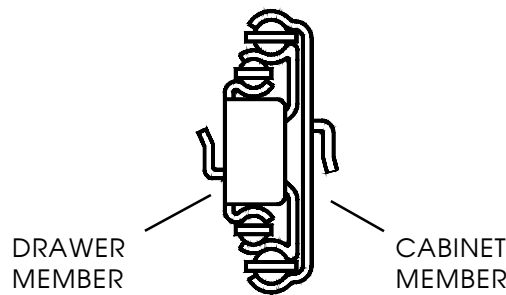

**Figure 4.** Upper Drawer Removal

slide and lower front pocket on front clip. Close the drawer completely. The mechanism will automatically latch.

### Drawer Slide Installation

FRONT VIEW



SIDE VIEW



**⚠ CAUTION**

**Pull out only one drawer at a time to avoid sudden tipping of product which could cause serious personal injury or property damage.**

5. Take one slide and insert rear clip into rear notch, and lower front clip into front notch (See Figure 5.).

### Drawer Slide Removal

6. Reverse step 5

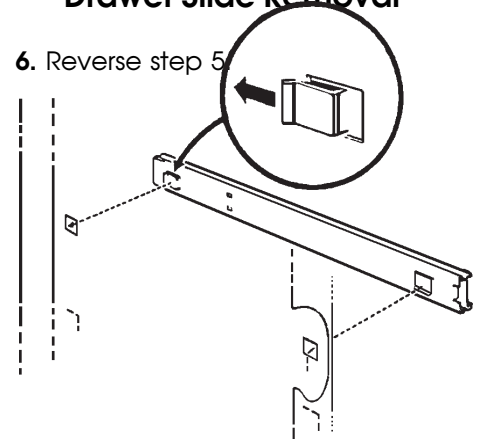

**Figure 5.** Drawer Slide Installation

### -NOTICE-

Any modification or unintended use of this product shall immediately void all manufacturers warranties. Manufacturer disclaims all liability for injuries to persons or property resulting from any modification to, or unintended use of this product.

