



# JOBSITE STORAGE SOLUTIONS

ALWAYS ON THE JOB™

# INSTALLATION MANUAL

## Caster Sets

**ATTENTION: PLEASE READ AND UNDERSTAND ALL INSTRUCTIONS AND WARNINGS BEFORE ASSEMBLING, INSTALLING OR USING THIS PRODUCT.**



### WARNING

Do not exceed load limits, shock or misuse these casters. This cause damage to the caster, causing the caster to collapse and/or the unit to tip over, causing serious personal injury or property damage. Any worn damaged casters should be replaced immediately. Failure to heed could result in death or serious injury.



### CAUTION

Caster Brakes are not suitable for keeping units in place when transporting. Secure by another method. Do not use casters on rough or uneven surfaces. Do not tow caster mounted boxes.

Install padlocks in all KNAACK® Boxes and lock the covers before laying them on their backs or tops for caster installation. This will keep the covers from opening and causing possible serious personal injury or property damage as the boxes are laid on their backs. Failure to heed may result in moderate injury.

### – NOTICE –

Any modification or unintended use of this product shall immediately void all manufacturers warranties. Manufacturer disclaims all liability for injuries to persons or property resulting from any modification to, or unintended use of this product.

### BOLT KITS

Two bolt kits have been included with your caster set, depending which type of skid you are mounting to.

#### BOLT KIT #32-0500 (For Use with Method 1)

	5/16"-18 x 3/4" Thread Cutting Bolt	16
---	-------------------------------------	----

#### BOLT KIT #32-0213 (For Use with Method 2)

	3/8" Flat Washer	16
	3/8-16 Nylon Lock Nut	16
	3/8-16 x 1" Carriage Bolt	16

### TOOLS REQUIRED

- 3/8" Drive Ratchet
- 3/8" Extension (6" minimum length)
- 1/2" Socket (for Method 1 mounting)
- 9/16" Socket (for Method 2 mounting)

### PARTS LIST

- 2 Swivel Casters
- 2 Fixed Casters

### INSTALLATION INSTRUCTIONS

Method 1  
Enclosed Skid Mounting

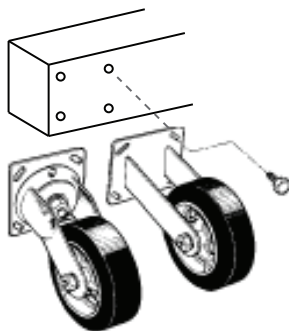

Method 2  
4-Way Skid Mounting

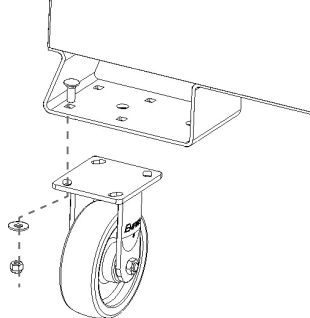

CASTER MODEL	SIZE	MAX. LOAD RATING PRE SET	BRAKE
495	4"	1600 Lbs.	Yes
695	6"	2600 Lbs.	Yes
516 non-marking	6"	2240 Lbs.	Yes

**Note:** Load Ratings are based on caster capacities and do not necessarily reflect load carrying capabilities of individual KNAACK® Products.

1. When installing on smaller products, lay shipping carton on the floor, and with a minimum of two people, lay the unit on it's back to avoid scratching product. On larger products, lift unit with forklift high enough to work at a comfortable height.
2. Decide which end you will steer from. The end you select will have the swivel casters.
3. For **Method 1**, use bolt kit # 32-0500, thread cutting bolts using the 1/2" socket. **Torque bolts to 20 ft. lbs. MAXIMUM.**
4. For **Method 2**, use bolt kit #32-0213 Carriage bolts, nuts and Washers. Tighten fasteners using the 9/16" socket, with orientation as shown in Method 2 figure above.