

HVNCVT1

INSTRUCTION MANUAL

Dual-Range High-Voltage Non-Contact Tester

Low Range: 50V to 1.5kV AC

High Range: 1.5kV to 132kV AC



**KLEIN
TOOLS**



For Professionals... Since 1857™

GENERAL SPECIFICATIONS

The Dual-Range High-Voltage Non-Contact Tester (HVNCVT1) checks for the presence of AC voltage without making any disconnection in cables, wall sockets, fuses, circuit breakers, junction boxes, etc. No current flow is needed for correct operation. The tester warns against dangerous voltage from low to high voltage applications up to 132kV without contacting the energized conductor. The low-range setting should be used for detecting 50V AC to 1.5kV AC. It may be used as a hand-held device ONLY when checking for low voltage. The high-range setting should be used for detecting 1.5kV AC to 132kV AC. It should ONLY be used with a hot stick when checking for high voltage.

Always follow approved work safety practices and clearances per OSHA Sub-parts R & V and all company work rules. For Minimum Approach Distances (MAD), see OSHA Tables R-6 and R-7 (pages 8 & 9) in this manual.

- **Operating Temperature:** 32° to 122°F (0° to 50°C) @ 85% relative humidity
- **Storage Temperature:** 14° to 122°F (-10° to 50°C) @ 85% relative humidity
- **Dimensions:** Tester: 13" x 3.15" x 2.64" (330 x 80 x 67mm)
Case: 14" x 8" x 3.5" (356 x 203 x 89 mm)
- **Weight:** 8 oz. (227 g)
- **Power Source:** One 9V battery
- **Power Consumption:** *Off:* Less than 5uA
Low range mode: (50V to 1.5kV AC) Less than 40mA
High range mode: (1.5kV to 132kV AC) Less than 40mA

Specifications subject to change.

SYMBOLS



Warning or Caution



Risk of Electrical Shock



Double Insulated

WARNINGS

To ensure safe operation and service of the tester, follow these instructions. Failure to observe these warnings can result in severe injury or death.

- Use extreme caution when testing live electrical circuits due to risk of injury from electrical shock.
- When testing for high voltage, always use hot sticks and rubber gloves meeting industry standards.
- Follow approved work safety practices and clearances per OSHA Sub-parts R & V and your company work rules.
- Always test on a known live circuit to verify tester functionality prior to use.
- Do not exceed the limits marked on the instrument itself. Never test voltage more than 132kV AC RMS.
- Never ground yourself when taking measurements. Do not touch exposed circuit elements.
- Observe the proper safety precautions when working with voltage above 30V AC RMS to avoid electrical shock hazard.
- Do not assume equipment or conductors are, or will remain, de-energized. Always install proper grounding devices before starting procedure.
- Do not operate tester in an explosive atmosphere.
- Do not expose tester to rain or moisture. This increases the risk of fire or electric shock.
- Do not rely on this tester for shielded wire or cable with concentric neutrals.
- Do not let the unit make contact with live line voltage. Do not touch any exposed wiring, connections or other energized parts of an electrical circuit.
- 3-phase feeder cables with conductors close to each other may self-cancel the electric field and not be detected by the device. Verify that the phase conductors are separated by at least 15" (381 mm) before testing for AC voltage.

FEATURE DETAILS

Front of Tester

Back of Tester

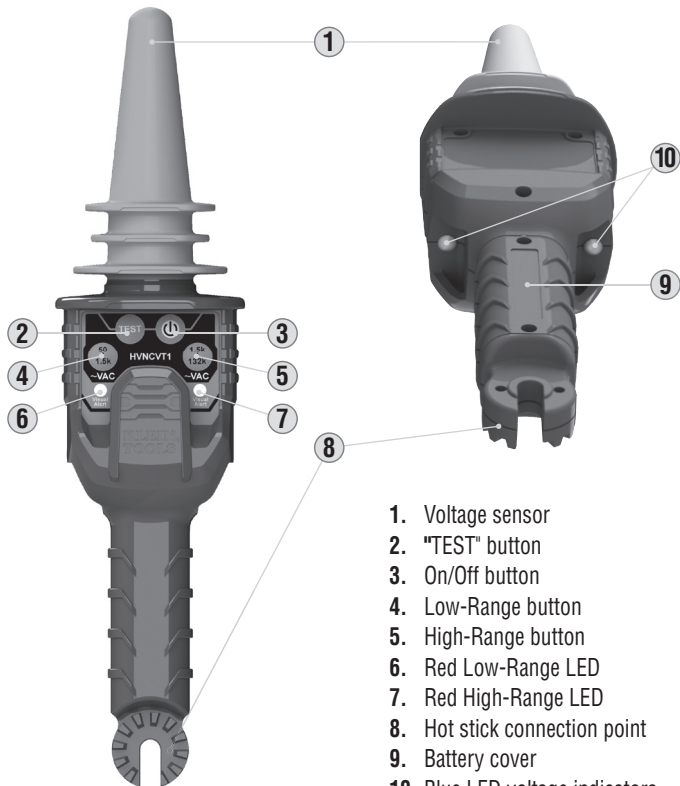

OPERATING INSTRUCTIONS

FOR USE BY TRAINED PERSONNEL ONLY

Anyone using this instrument should be knowledgeable and trained about the risks involved with measuring medium and high voltage. They must also understand the importance of taking safety precautions as well as testing the instrument before and after using it to ensure that it is in good working condition.

EXAMPLES OF APPLICATIONS:

- Non-contact detection of live AC voltage
- Finding faults in cables
- Checking and detecting live high voltage cables
- Tracing live wires
- Checking grounding equipment

Fig. 1: Ideal detection angle

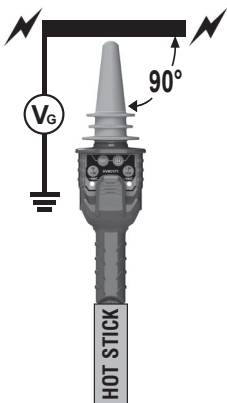

Fig. 2: Finding a cable fault



Fig. 3: Voltage detection for overhead lines



OPERATING INSTRUCTIONS

Prior to use, always inspect the tester for visible signs of damage. If there is any sign of damage, or if the tester does not operate correctly, discontinue use.

Always test on a known live circuit to verify tester functionality. The tester should be used as an indication only.

Tester should be kept clean and dry. If it is not, wipe with a clean, dry lint-free cloth.

MODES OF OPERATION

The HVNCT1 can operate in two ranges. In low-range mode, the red LED ⑥ below the low-range button ④ will illuminate. In high-range mode, the red LED ⑦ below the high-range button ⑤ will illuminate. See **FEATURE DETAILS** for locations of red LEDs.

ON/OFF BUTTON

Press the on/off button ③ to turn the unit on or off. When the unit is turned on, the two blue LEDs ⑩ will flash and the unit will emit a high-pitched beep sound. See **FEATURE DETAILS** for locations of blue LEDs.

"TEST" BUTTON

Press and hold the TEST button ② to perform a self-test on the unit. Look for a steady blue LED light ⑩ and listen for a steady beep sound. This self-test function **ONLY** confirms battery sufficiency, system integrity, and operation/active mode. Always test on known live circuit to verify tester functionality prior to use. ***If the two blue LEDs do not glow and the beep sound is not present, replace battery.***

LOW-RANGE BUTTON

When the unit is turned on, press the low-range button ④ to switch the unit to the low-range setting. Look for a steady red LED ⑥ below the low-range button. Also look for the two blue LEDs ⑩ to blink and listen for a beep sound.

The Low range is 50V AC to 1.5kV AC.

Place the probe tip of the tester ① near a low voltage source, but not touching it. Look for the blue LEDs ⑩ to blink quickly and listen for a quickened beep sound when voltage is present. As the probe tip gets closer to the voltage source, the blue LEDs and beep sound will be constant. See Fig. 1 on page 5 for ideal detection angle. Always

OPERATING INSTRUCTIONS

maintain the minimum approach distances listed in OSHA Tables R-6 and R-7 on pages 8 & 9 in this manual.

HIGH-RANGE BUTTON

Before using the unit in High range, hot stick must be attached. Only use with hot sticks and rubber gloves meeting industry standards. Always follow approved work safety practices and clearances per OSHA Sub-parts R & V and all company work rules.

When the unit is turned on, press the high-range button **5** to switch the unit to the high-range setting. Look for a steady red LED **7** below the high-range button. Also look for the two blue LEDs **10** to blink and listen for a beep sound.

The High range is 1.5kV AC to 132kV AC.

Place the probe tip of the tester **1** near a high voltage source, but not touching it. Look for the blue LEDs **10** to blink quickly and listen for a quickened beep sound when voltage is present. As the probe tip gets closer to the voltage source, the blue LEDs and beep sound will be constant. See Fig. 1 on page 5 for ideal detection angle. Always maintain the minimum approach distances listed in OSHA Tables R-6 and R-7 on pages 8 & 9 in this manual.

FINDING FAULTS IN CABLE

The tester may be used for finding faults in some flexible cables. Press the appropriate button for low-range **4** or high-range **5** according to the voltage of the energized cable being detected. Move the tester along (but not touching) the cable, listening for the rapid beeping or steady sound and looking for the rapid blinking or steady light from the blue LEDs **10**. When the fault is reached, the unit will no longer beep or blink. See Fig. 2 on page 5. Always maintain the minimum approach distances listed in OSHA Tables R-6 and R-7 on pages 8 & 9 in this manual.

OPERATING INSTRUCTIONS

Always follow approved work safety practices and clearances per OSHA Sub-parts R & V and all company work rules. For Minimum Approach Distances (MAD), see OSHA Tables R-6 and R-7 below.

**TABLE R-6 – ALTERNATIVE MINIMUM APPROACH DISTANCES
FOR VOLTAGES OF 72.5 kV AND LESS¹**

Nominal voltage (kV) phase-to-phase	Distance			
	Phase-to-ground exposure		Phase-to-phase exposure	
	ft.	m	ft.	m
0.050 to 0.300²	Avoid Contact	Avoid Contact	Avoid Contact	Avoid Contact
0.301 to 0.750²	1.09	0.33	1.09	0.33
0.751 to 5.0	2.07	0.63	2.07	0.63
5.1 to 15.0	2.14	0.65	2.24	0.68
15.1 to 36.0	2.53	0.77	2.92	0.89
36.1 to 46.0	2.76	0.84	3.22	0.98
46.1 to 72.5	3.29	1.00	3.94	1.20

¹ Employers may use the minimum approach distances in this table provided the worksite is at an elevation of 3,000 feet (900 meters) or less. If employees will be working at elevations greater than 3,000 feet (900 meters) above mean sea level, the employer shall determine minimum approach distances by multiplying the distances in this table by the correction factor in OSHA's Table R-5 Altitude Correction Factor, corresponding to the altitude of the work.

² For single-phase systems, use voltage-to-ground.

OPERATING INSTRUCTIONS

**TABLE R-7-ALTERNATIVE MINIMUM APPROACH DISTANCES
FOR VOLTAGES OF MORE THAN 72.5 kV^{1 2 3}**

Nominal voltage (kV) phase-to-phase	Distance			
	Phase-to-ground exposure		Phase-to-phase exposure	
	ft.	m	ft.	m
72.6 to 121.0	3.71	1.13	4.66	1.42
121.1 to 145.0	4.27	1.30	5.38	1.64
145.1 to 169.0	4.79	1.46	6.36	1.94
169.1 to 242.0	6.59	2.01	10.10	3.08
242.1 to 362.0	11.19	3.41	18.11	5.52
362.1 to 420.0	13.94	4.25	22.34	6.81
420.1 to 550.0	16.63	5.07	27.03	8.24
550.1 to 800.0	22.57	6.88	37.34	11.38

¹ Employers may use the minimum approach distances in this table provided the worksite is at an elevation of 3,000 feet (900 meters) or less. If employees will be working at elevations greater than 3,000 feet (900 meters) above mean sea level, the employer shall determine minimum approach distances by multiplying the distances in this table by the correction factor in OSHA's Table R-5 Altitude Correction Factor, corresponding to the altitude of the work.

² Employers may use the phase-to-phase minimum approach distances in this table provided that no insulated tool spans the gap and no large conductive object is in the gap.

³ The clear live-line tool distance shall equal or exceed the values for the indicated voltage ranges.

OPERATING INSTRUCTIONS

PROTECTIVE CLOTHING AND PERSONAL PROTECTIVE EQUIPMENT (PPE)

TABLE 130.7 (C) (16) FROM NFPA 70E 2015

Note below that this new PPE category table no longer references a category 0.

PPE Category*	Clothing	Min. APTV Rating Cal/cm ²	Required Garments	Required Protective Equipment
1	Arc-rated clothing ¹ and PPE	4	Long-sleeve shirt and pants or coverall. Flash suit hood or face shield ² . Jacket, parka, rainwear or hard hat liner (AN).	Hard hat. Safety glasses or safety goggles (SR). Hearing protection (ear canal inserts). Heavy duty leather gloves ³ . Leather footwear (AN).
2	Arc-rated clothing ¹ and PPE	8	Long-sleeve shirt and pants or coverall. Flash suit hood or face shield ² and balaclava. Jacket, parka, rainwear or hard hat liner (AN).	Hard hat. Safety glasses or safety goggles (SR). Hearing protection (ear canal inserts). Heavy duty leather gloves ³ . Leather footwear (AN).
3	Arc-rated clothing system ¹ and PPE	25	Long sleeve shirt (AR). Pants (AR). Coverall (AR). Flash suit jacket (AR). Flash suit pants (AR). Flash suit hood. Gloves ¹ . Jacket, parka, rainwear or hard hat liner (AN).	Hard hat. Safety glasses or safety goggles (SR). Hearing protection (ear canal inserts). Leather footwear (AN).
4	Arc-rated clothing system ³ and PPE	40	Long sleeve shirt (AR). Pants (AR). Coverall (AR). Flash suit jacket (AR). Flash suit pants (AR). Flash suit hood. Gloves ¹ . Jacket, parka, rainwear or hard hat liner (AN).	Hard hat. Safety glasses or safety goggles (SR). Hearing protection (ear canal inserts). Leather footwear (AN).

AN = as needed (optional) AR = as required SR = selection required

* One of the 3 basic methods is used to determine an HRC for a job task.

¹ Arc rating is defined in article 100 NFPA 70E 2015 Edition.

² Face shields are to have wrap-around guarding to protect not only the face but also the forehead, ears and neck, or alternatively, an arc-rated flash suit hood is required to be worn.

³ If rubber insulating gloves with leather protectors are used, additional leather or arc-rated gloves are not required. The combination of rubber insulating gloves with leather protectors satisfies the arc flash protection requirement.

MAINTENANCE

BATTERY REPLACEMENT

1. Unscrew the battery cover on the rear and lift the battery cover off the tester.
2. Remove old battery.
3. Replace with a new battery (9V).
4. Reinstall the battery cover and fasten the cover screws.

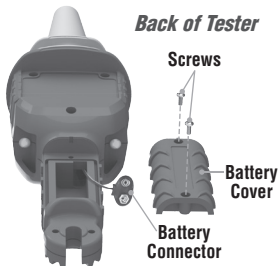

CLEANING

Be sure tester is turned off and wipe with a clean, dry lint-free cloth. ***Do not use abrasive cleaners or solvents.***

STORAGE

If the tester is not to be used for periods of longer than 60 days, remove the battery and store separately from the tester.