



Two Stage Air Compressor

Operating Instructions and Parts Manual



Model: JCP-801

Part No. M-506801



Please read and save these instructions. Read carefully before attempting to assemble, install, operate or maintain the product described.

Protect yourself and others by observing all safety information. Failure to comply with instructions could result in personal injury and/or property damage! Retain instructions for future reference.

REMINDER: Keep your dated proof of purchase for warranty purposes! Attach it to this manual or file it for safekeeping.

BEFORE YOU BEGIN

Introduction

The JET two-stage air compressors are oil lubricated reciprocating compressors.

General Purpose Series Models Include:

- Compressor pump
- ASME air receiver with safety valve
- Electric motor
- Pressure switch

Quick Reference
Recommended Oil (2 Options)
Single viscosity SAE 30 ISO100 nondetergent compressor oil.
10W30 synthetic oil such as Mobil 1®.
Oil Capacity
Approximately 18 ounces

UNPACKING

⚠ CAUTION *Do not lift or move unit without appropriately rated equipment. Be sure the unit is securely attached to lifting device used. Do not lift unit by holding onto tubes or coolers. Do not use unit to lift other attached equipment.*

After unpacking the unit, inspect carefully for any damage that may have occurred during transit. Check for loose, missing or damaged parts. Check to be sure all supplied accessories are enclosed with the unit.

⚠ WARNING *Do not operate unit if damaged during shipping, handling or use. Damage may result in bursting and cause injury or property damage.*

Required Items - Not Included

- Oil

GENERAL SAFETY INSTRUCTIONS

Safety Guidelines

This manual contains information that is very important to know and understand. This information is provided for SAFETY and to PREVENT EQUIPMENT PROBLEMS. To help recognize this information, observe the following symbols.



DANGER *Danger indicates an imminently hazardous situation which, if not avoided, WILL result in death or serious injury.*



WARNING *Warning indicates a potentially hazardous situation which, if not avoided, COULD result in death or serious injury.*



CAUTION *Caution indicates a potentially hazardous situation which, if not avoided, MAY result in minor or moderate injury.*

NOTICE

NOTICE *Notice indicates important information, that if not followed, may cause damage to equipment.*

IMPORTANT: Information that requires special attention.

Safety Symbols

The following Safety Symbols appear throughout this manual to alert you to important safety hazards and precautions.



Wear Eye and Mask Protection



Read Manual First



Risk of Fire



Risk of Moving Parts



Risk of Hot Parts



Risk of Explosion



Risk of Fumes



Risk of Pressure



Risk of Shock

California Proposition 65



WARNING *This product or its power cord may contain chemicals known to the State of California to cause cancer and birth defects or other reproductive harm. Wash hands after handling.*



WARNING *You can create dust when you cut, sand, drill or grind materials such as wood, paint, metal, concrete, cement, or other masonry. This dust often contains chemicals known to cause cancer, birth defects, or other reproductive harm. Wear protective gear.*

Important Safety Information

Please read and save these instructions. Read carefully before attempting to assemble, install, operate or maintain the product described. Protect yourself and others by observing all safety information. Failure to comply with instructions could result in personal injury and/or property damage! Retain instructions for future reference.

This manual contains important safety, operational and maintenance information.

Since the air compressor and other components (material pump, spray guns, filters, lubricators, hoses, etc.) used make up a high pressure pumping system, the following safety precautions must be observed at all times:

Important Safety Information (Continued)

⚠ DANGER

BREATHABLE AIR WARNING

This compressor/pump is not equipped and should not be used “as is” to supply breathing quality air. For any application of air for human consumption, the air compressor/pump will need to be fitted with suitable in-line safety and alarm equipment. This additional equipment is necessary to properly filter and purify the air to meet minimal specifications for Grade D breathing as described in Compressed Gas Association Commodity Specification G 7.1, OSHA 29 CFR 1910. 134, and/or Canadian Standards Associations (CSA).

DISCLAIMER OF WARRANTIES

In the event the compressor is used for the purpose of breathing air application and proper in-line safety and alarm equipment is not simultaneously used, existing warranties shall be voided, and the manufacturer disclaims any liability whatsoever for any loss, personal injury or damage.

General Safety



- Read all manuals included with this product carefully. Be thoroughly familiar with the controls and the proper use of the equipment.
- Follow all local electrical and safety codes as well as the United States National Electrical Codes (NEC) and Occupational Safety and Health Act (OSHA).
- Only persons well acquainted with these rules of safe operation should be allowed to use the compressor.
- Keep visitors away and NEVER allow children in the work area.
- Wear safety glasses and use hearing protection when operating the unit.
- Do not stand on or use the unit as a handhold.
- Before each use, inspect compressed air system and electrical components for signs of damage, deterioration, weakness or leakage. Repair or replace defective items before using.
- Check all fasteners at frequent intervals for proper tightness.



⚠ WARNING *Motors, electrical equipment and controls can cause electrical arcs that will ignite a flammable gas or vapor. Never operate or repair in or near a flammable gas or vapor. Never store flammable liquids or gases in the vicinity of the compressor.*



⚠ WARNING *Never operate compressor without a beltguard. This unit can start automatically without warning. Personal injury or property damage could occur from contact with moving parts.*

- Do not wear loose clothing or jewelry that will get caught in the moving parts of the unit.



⚠ CAUTION *Compressor parts may be hot even if the unit is stopped.*

- Keep fingers away from a running compressor; fast moving and hot parts will cause injury and/or burns.
- If the equipment should start to vibrate abnormally, STOP the engine/motor and check immediately for the cause. Vibration is generally an indication of trouble.
- To reduce fire hazard, keep engine/motor exterior free of oil, solvent, or excessive grease.

⚠ WARNING *An ASME code safety relief valve with a setting no higher than the Maximum Allowable Working Pressure (MAWP) of the tank MUST be installed in the air lines or in the tank for this compressor. The ASME safety valve must have sufficient flow and pressure ratings to protect the pressurized components from bursting. The flow rating can be found in the parts manual. The safety valve in the intercooler does not provide system protection.*

⚠ WARNING *Maximum operating pressure is 175 psi for two-stage compressors. Do not operate with pressure switch or pilot valves set higher than 175 psi (two-stage).*

- Never attempt to adjust ASME safety valve. Keep safety valve free from paint and other accumulations.

Important Safety Information (Continued)**⚠ WARNING**

Never use plastic (PVC) pipe for compressed air. Serious injury or death could result.

**⚠ WARNING**

Never attempt to repair or modify a tank! Welding, drilling or any other modification will weaken the tank resulting in damage from rupture or explosion. Always replace worn, cracked or damaged tanks.

NOTICE

Drain liquid from tank daily.

- Tanks rust from moisture build-up, which weakens the tank. Make sure to drain tank regularly and inspect periodically for unsafe conditions such as rust formation and corrosion.
- Fast moving air will stir up dust and debris which may be harmful. Release air slowly when draining moisture or depressurizing the compressor system.

Spraying Precautions**⚠ WARNING**

Do not spray flammable materials in vicinity of open flame or near ignition sources including the compressor unit.



- Do not smoke when spraying paint, insecticides, or other flammable substances.
- Use a face mask/respirator when spraying and spray in a well ventilated area to prevent health and fire hazards.
- Do not direct paint or other sprayed material at the compressor. Locate compressor as far away from the spraying area as possible to minimize overspray accumulation on the compressor.
- When spraying or cleaning with solvents or toxic chemicals, follow the instructions provided by the chemical manufacturer.

Save These Instructions
Do Not Discard

The **DANGER, WARNING, CAUTION, and NOTICE** notifications and instructions in this manual cannot cover all possible conditions and situations that may occur. It must be understood by the operator that caution is a factor which cannot be built into this product, but must be supplied by the operator.

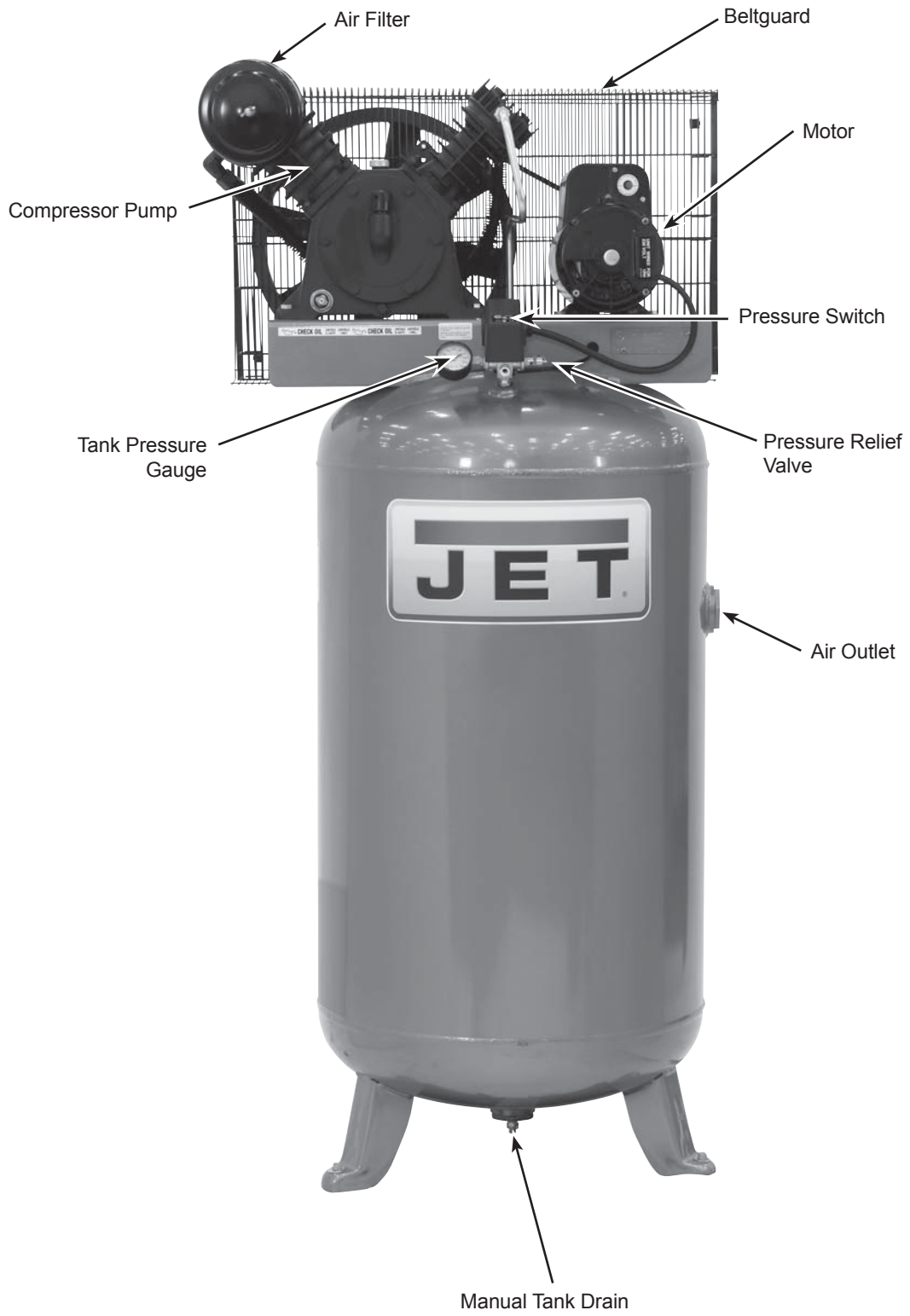

Figure 1 - Compressor Features

SPECIFICATIONS

JCP-801	
Stock Number	506801
Motor HP	5
Power	230
Phase	1
Displacement CFM	17.3
Air Delivery CFM	13.7 @ 175 PSI
Max PSI	175
Pump RPM	1190
Tank Capacity	80
Unit Weight	460 lb
Amp Draw	22
Max Duty Cycle	80/20
Tank Outlet	3/4 (F) NPT
Tank MAWP	200 PSI
Sound Rating	87 dB(A) at 1M

DIMENSIONS

JCP-801	
Length	35 inches
Width	27 inches
Height	71 inches

BOLT DOWN PATTERN

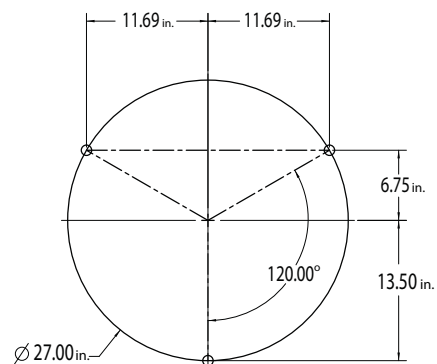

INSTALLATION INSTRUCTIONS



⚠ WARNING

Disconnect, tag and lock out power source then release all pressure from the system before attempting to install, service, relocate or perform any maintenance.

⚠ CAUTION

Do not lift or move unit without appropriately rated equipment. Be sure the unit is securely attached to lifting device used. Do not lift unit by holding onto tubes or coolers. Do not use unit to lift other attached equipment.

⚠ CAUTION

Never use the wood shipping skids for mounting the compressor.

Picking the Location

Install and operate unit at least 24 inches from any obstructions in a clean, well ventilated area. The surrounding air temperature should not exceed 100° F. This will ensure an unobstructed flow of air to cool compressor and allow adequate space for maintenance.

⚠ CAUTION

Do not locate the compressor air inlet near steam, paint spray, sandblast areas or any other source of contamination.

NOTE: If compressor operates in a hot, moist environment, supply compressor pump with clean, dry outside air. Supply air should be piped in from external sources.

Tank Mounting

The tank should be bolted into a flat, even, concrete floor or on a separate concrete foundation. Vibration isolators should be used between the tank leg and the floor.

When using isolator pads, **do not draw bolts tight**. Allow the pads to absorb vibrations. When isolators are used, a flexible hose or coupling should be installed between the tank and service piping.

⚠ WARNING

Failure to properly install the tank can lead to cracks at the welded joints and possible bursting.

Piping

⚠ WARNING

Never use plastic (PVC) pipe for compressed air. Serious injury or death could result.

Any tube, pipe or hose connected to the unit must be able to withstand the temperature generated and retain the pressure. All pressurized components of the air system must have a pressure rating of 200 psi or higher. Incorrect selection and installation of any tube, pipe or hose could result in bursting and injury. Connect piping system to tank using the same size fitting as the discharge port.

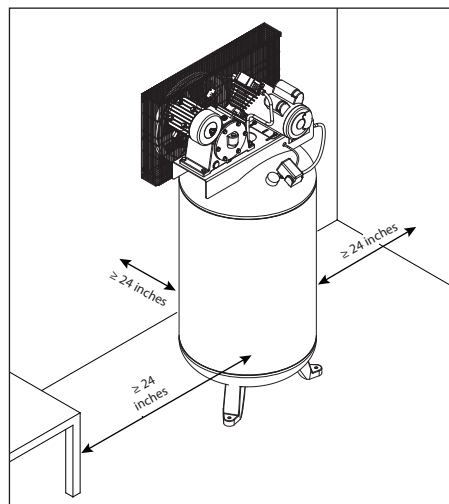

Figure 2 - Location

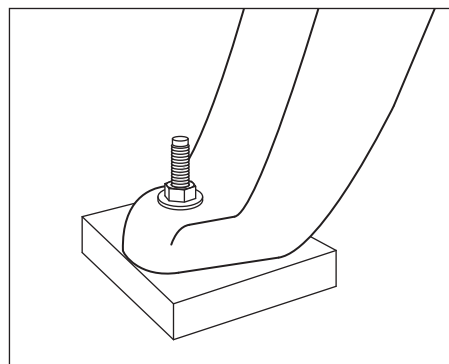

Figure 3 - Isolator Pad

Minimum Pipe Size For Compressed Air Line

CFM	Length Of Piping System			
	25 feet	50 feet	100 feet	250 feet
10	1/2 inch	1/2 inch	3/4 inch	3/4 inch
20	3/4 inch	3/4 inch	3/4 inch	1 inch
40	3/4 inch	1 inch	1 inch	1 inch
60	3/4 inch	1 inch	1 inch	1 inch
100	1 inch	1 inch	1 inch	1-1/4 inch

INSTALLATION INSTRUCTIONS (CONTINUED)

Installing A Shut-Off Valve

A shut-off valve (not provided) should be installed on the discharge port of the tank to control the air flow out of the tank. The valve should be located between the tank and the piping system.

⚠ WARNING

Never install a shut-off valve between the compressor pump and the tank. Personal injury and/or equipment damage may occur. Never use reducers in discharge piping.



Figure 4 - Shut-off Valve

When creating a permanently installed system to distribute compressed air, find the total length of the system and select pipe size from the chart. Bury underground lines below the frost line and avoid pockets where condensation can gather and freeze.

Apply air pressure to the piping installation and make sure all joints are free from leaks BEFORE underground lines are covered. Before putting the compressor into service, find and repair all leaks in the piping, fittings and connections.

Wiring**⚠ WARNING**

All wiring and electrical connections must be performed by a qualified electrician familiar with induction motor controls. Installations must be in accordance with local and national codes.

⚠ WARNING

Overheating, short circuiting and fire damage will result from inadequate wiring.

Wiring must be installed in accordance with National Electrical Code and local codes and standards that have been set up covering electrical apparatus and wiring. These should be consulted and local ordinances observed. Be certain that adequate wire sizes are used, and that:

1. Service is of adequate ampere rating.
2. The supply line has the same electrical characteristics (voltage, cycles and phase) as the motor. Refer to motor name plate for electrical ratings and specifications.
3. The line wire is the proper size and that no other equipment is operated from the same line. The chart gives minimum recommended wire sizes for compressor installations.

Minimum Wire Size (Use 75°C Copper Wire)

Make sure voltage is correct with the motor wiring.

NOTE: If using 208 volts single phase, make sure the motor name plate states it is rated for 208 volts single phase. 230 volt single phase motors do not work on 208 volts unless they have the 208 volt rating.

HP	Amps	Single Phase
		230V
SPL	up to 22.0	10 AWG
5.0		8 AWG

Recommended wire sizes may be larger than the minimum set up by local ordinances. If so, the larger size wire should be used to prevent excessive line voltage drop. The additional wire cost is very small compared with the cost of repairing or replacing a motor electrically "starved" by the use of supply wires which are too small.

INSTALLATION INSTRUCTIONS (CONTINUED)

Grounding

⚠ WARNING *Improperly grounded electrical components are shock hazards. Make sure all the components are properly grounded to prevent death or serious injury.*

This product **must** be grounded. Grounding reduces the risk of electrical shock by providing an escape wire for the electric current if short circuit occurs. This product must be installed and operated with a power cord or cable that has a grounding wire.

Breakers and Fuses

The entire electrical system should be checked by a certified electrician. Time delay breakers and fuses are required for this compressor. A tripped breaker or blown fuses may indicate a direct short to ground, high current draw, improper wiring, incorrect fuse or breaker size and/or type. This needs to be evaluated by a certified electrician.

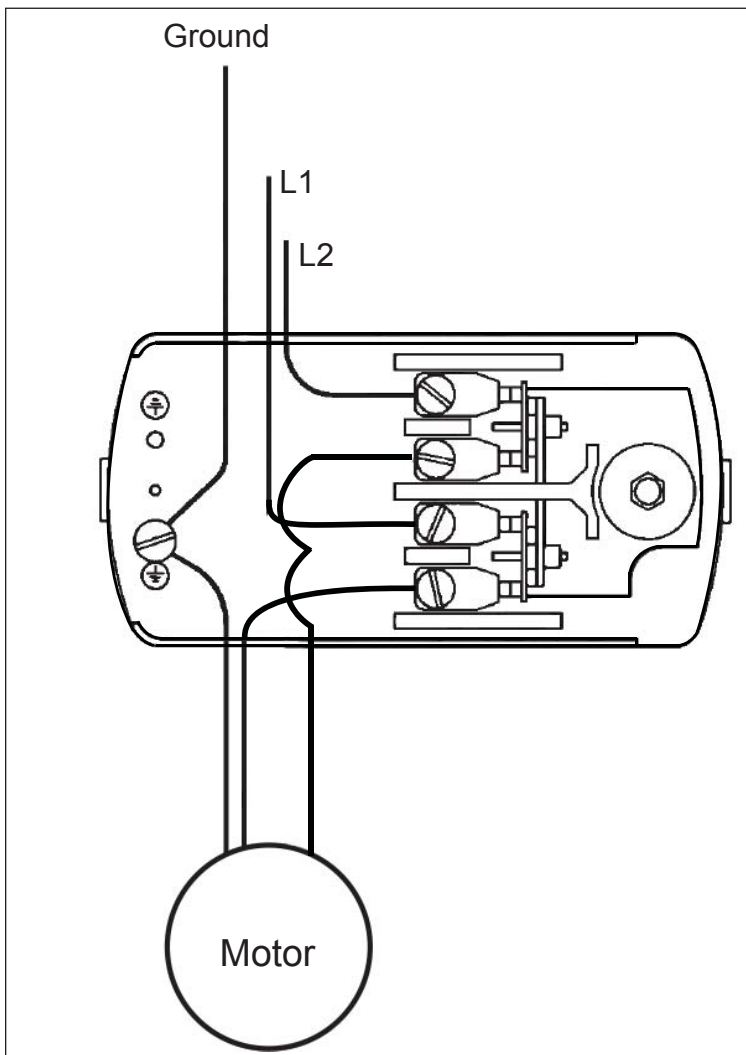

Figure 5 - Wiring Diagram

INSTALLATION INSTRUCTIONS (CONTINUED)

Installing Air Inlet Filter

Screw supplied air inlet filter into inlet port of cast iron pump as indicated in Figure 6.

Lubrication

⚠ CAUTION *This unit contains no oil. Before operating compressor, fill to the center of the sight gauge (see Figure 6).*

⚠ CAUTION *Using any other type of oil may shorten pump life and damage valves.*

Recommended Oil (2 Options)

Single viscosity SAE 30 ISO100 nondetergent compressor oil.

10W30 synthetic oil such as Mobil 1®.

Oil Capacity

Approximately 18 ounces

Fill the pump with oil to the center of the sight gauge using oil fill opening (see Figure 6). Do NOT fill the pump through the breather cap opening as this may cause oil to leak and spray out during operation.

NOTE: Some residual oil may still be in the pump from factory testing leaving a thin coat on the sight gauge; however, there is not enough oil to operate the unit.

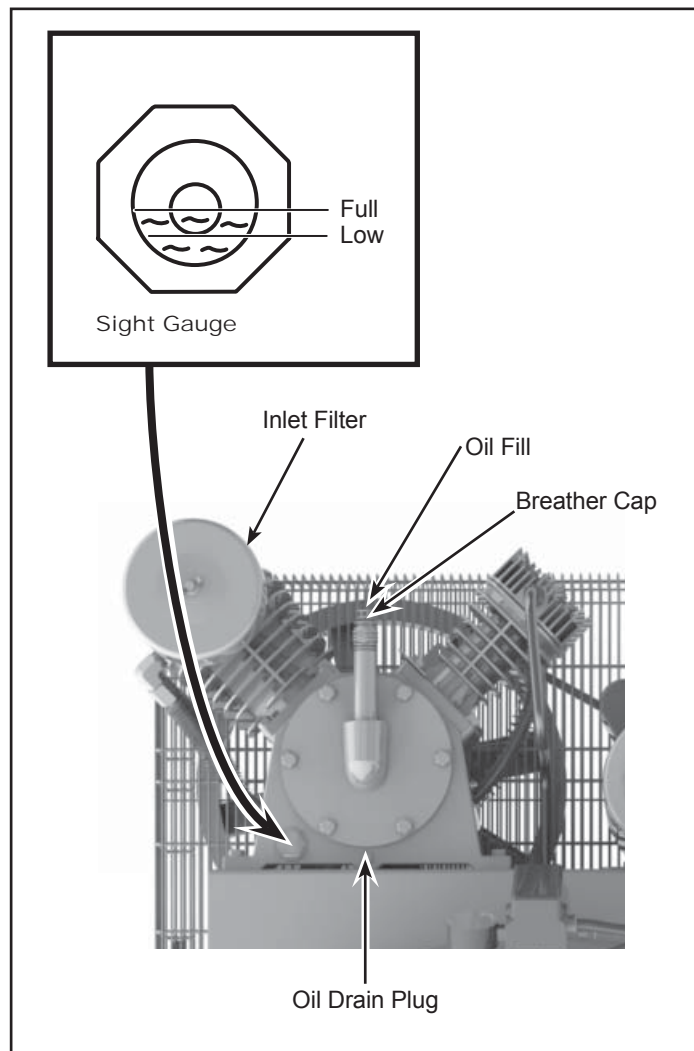

Figure 6

OPERATING INSTRUCTIONS

IMPORTANT: Check motor rotation before operating the compressor.

All lubricated compressor pumps discharge some condensed water and oil with the compressed air. Install appropriate water/oil removal equipment and controls as necessary for the intended application.

NOTICE

Failure to install appropriate water/oil removal equipment may result in damage to machinery or workpiece.



Guarding

WARNING

The belt guard provided must be installed before operating the unit.

All moving parts must be guarded. All electrical covers must be installed before turning on the power.

Recommended Break-In Period

The compressor should be run continuously for one hour to allow proper seating of the piston rings.

1. Open drain cock completely and run the compressor for 60 minutes.
2. Turn off the compressor and close drain cock. The compressor is now ready for use.

Pressure Switch, Start - Stop

NOTE: This compressor has a maximum operating pressure of 175 PSI for two-stage compressors or 135 PSI for single stage compressors. Do not alter pressure settings on control components above this limit.

The compressor unit starts and stops based on preset pressure switch settings. The pressure switch contains an unloader which is a small valve that vents air to allow the motor to start easily (See Figure 7).

Crankcase Breather

During severe operating conditions or initial start-up, some oil may accumulate at the crankcase breather opening. This is normal and will diminish as the pump accumulates run time and the piston rings become fully seated.

Draining Tank

Condensation must be drained from the tank daily.

Duty Cycle

Each pump on this compressor is designed to operate up to 75% of the time. Long-term or on-time operation over 75% could decrease the life of the pump and motor.

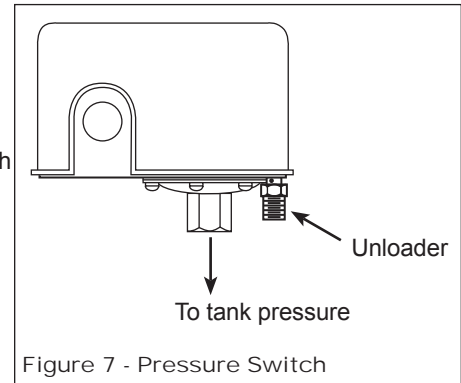

Figure 7 - Pressure Switch

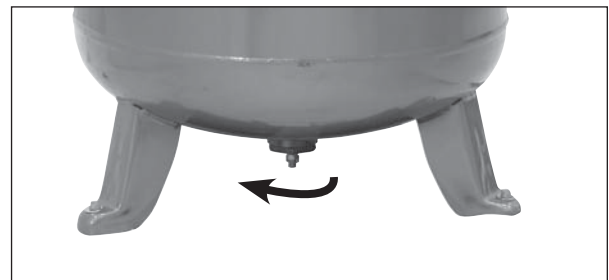

Figure 8 - Manual Tank Drain

TROUBLESHOOTING CHART

Symptom	Possible Cause(s)	Corrective Action
Motor hums and runs slowly or not at all	1. Low voltage or no voltage	1. Check with voltmeter, check overload relay in magnetic starter or reset switch on motor. If overload or reset switch trips repeatedly, find and correct the cause. See next item
	2. Shorted or open motor winding	2. Replace motor
	3. Malfunctioning check valve or unloader valve	3. Replace check valve or unloader valve
	4. Malfunctioning pressure switch - contacts will not close	4. Repair or replace pressure switch
Reset mechanism cuts out repeatedly or fuses blow repeatedly	1. Pressure switch set too high	1. Replace pressure switch
	2. Malfunctioning check valve	2. Clean or replace faulty valve
	3. Incorrect fuse size or magnetic starter heaters	3. Be sure that fuses and heaters are rated properly
	4. Malfunctioning motor	4. Replace motor
	5. Loose Wiring	5. Check all electrical connections
Excessive noise in operation	1. Loose pulley, flywheel, belt, belt guard, etc	1. Tighten
	2. Lack of oil in crankcase	2. Check for damage to bearings, replenish oil
	3. Compressor floor mounting loose	3. Shim to level and tighten or place on isolator pads
	4. Malfunctioning check valve	4. Replace check valve
	5. Unit not on vibration pads	5. Install vibration pads under compressor feet
Milky oil in oil crankcase	1. Low usage of compressor - water is condensing in the crankcase	1. Run the compressor continuously for 1 hour. The heat generated during this running period will evaporate the moisture out of the oil
	2. Wrong type of oil	2. Do not use SAE-30 automotive type oil. Using the wrong oil can cause various problems with the pump and will void the warranty. Only use the oils that the operating manual recommends
	3. Improper environment	3. Unit should not be installed in a poorly vented area or exposed to extreme cold or hot conditions. Normal operating range should be between 32°F and 100°F
	4. Rotation incorrect	4. Check to make sure the compressor is running the direction of the flywheel arrow. Air flow should be so that the flywheel directs air across the head of the pump. Standing in front of the compressor (non-belt guard side) air should flow back to front
	5. Slight leakage of tank check valve	5. Air cools and condensates, then leaks back into the pump. Draining tank of air after use will normally take care of this situation
Excessive oil consumption or oil in air lines	1. Be sure there is a problem	1. Diagnose oil contamination problems by testing the discharge air or measuring oil consumption from the crankcase
	2. Restricted air intake	2. Clean or replace air filter
	3. Wrong oil viscosity	3. Drain oil. Refill with oil of proper viscosity
	4. Worn piston rings	4. Replace rings
	5. Oil leaks	5. Tighten bolts, replace gaskets or o-rings
	6. Scored cylinder	6. Replace cylinder
Water in discharge air	1. Excessive water in tank	1. Drain tank
	2. Hot, humid weather	2. Purchase dryer
Air blowing out of inlet	1. Broken first stage inlet valve (two-stage unit)	1. Replace valve assembly
	2. Broken inlet valve (single stage unit)	2. Replace valve assembly
Insufficient pressure	1. Air demand too high	1. Limit air usage
	2. Leaks or restrictions in hoses or piping	2. Check for leaks or restriction in hose or piping
	3. Slipping belts	3. Tighten belts
Tank does not hold pressure when compressor is off and shutoff valve is closed	1. Worn check valve	1. Replace check valve
	2. Check all connections and fittings for tightness	2. Tighten
	3. Check tank for cracks or pin holes	3. Replace tank. Never repair a damaged tank

**DANGER*****Do not disassemble check valve with air in tank***

Symptom	Possible Cause(s)	Corrective Action
Excessive belt wear. (Light dust from start is normal. Worn belts separate at layers)	<ol style="list-style-type: none"> 1. Pulley out of alignment 2. Belts too tight or too loose 	<ol style="list-style-type: none"> 1. Realign motor pulley 2. Adjust tension
Tank pressure builds slowly	<ol style="list-style-type: none"> 1. Dirty air filter 2. Blown cylinder head gasket 3. Worn/broken intake/discharge valves 4. Air leaks 	<ol style="list-style-type: none"> 1. Clean or replace filter element 2. Install new gasket 3. Install new valve plate assembly 4. Tighten joints
Tank pressure builds up quickly on compressor	Excessive water in tank	Drain tank, check speed. See Performance table
ASME safety valve pops open while compressor is running	<ol style="list-style-type: none"> 1. Pressure switch setting to high 2. Malfunctioning ASME safety valve 3. Pressure switch contacts welded 	<ol style="list-style-type: none"> 1. Replace pressure switch 2. Replace ASME safety valve 3. Replace pressure switch
Pressure switch continuously blows air out the unloader valve	Malfunctioning check valve	Replace the check valve if the unloader valve bleeds off constantly
Pressure switch unloader valve does not release air when the unit shuts off	Malfunctioning unloader valve on pressure switch	Replace the pressure switch if the unit does not hiss for a short period of time when the unit shuts off
Interstage safety valve pops off while the unit is running	<ol style="list-style-type: none"> 1. Head gasket or the gasket in the valve plate assembly blown 2. Valve not seating properly 3. Malfunctioning safety valve 	<ol style="list-style-type: none"> 1. Replace valve plate and gaskets 2. Replace valve plate and gaskets 3. Replace safety valve
Interstage safety valve pops off after the unit shuts off	Malfunctioning tank check valve	Replace the check valve

MAINTENANCE AND INSPECTION INSTRUCTIONS

**⚠ WARNING**

Disconnect, tag and lock out power source then release all pressure from the system before attempting to install, service, relocate or perform any maintenance.

In order to maintain efficient operation of the compressor system, check the air filter and oil level before each use. The ASME safety valve should also be checked daily (see Figure 9). Pull ring on safety valve and allow the ring to snap back to normal position. This valve automatically releases air if the tank pressure exceeds the preset maximum. If air leaks after the ring has been released, or the valve is stuck and cannot be actuated by the ring, the ASME safety valve must be replaced.

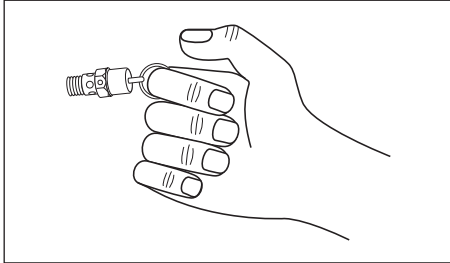

Figure 9 - ASME Safety Valve

⚠ WARNING

Do not tamper with the ASME safety valve.

Tank**⚠ WARNING**

Never attempt to repair or modify a tank! Welding, drilling or any other modification will weaken the tank resulting in damage from rupture or explosion.

Always replace worn, cracked or damaged tanks.

NOTICE

Drain liquid from tank daily.

The tank should be carefully inspected at a minimum of once a year. Look for cracks forming near the welds. If a crack is detected, remove pressure from tank immediately and replace.

Compressor Lubrication

See Installation. Add oil as required. The oil should be changed every three months or after every 500 hours of operation; whichever comes first.

If the compressor is running under humid conditions for short periods of time, the humidity will condense in the crankcase and cause the oil to look creamy. Oil contaminated by condensed water will not provide adequate lubrication and must be changed immediately. Using contaminated oil will damage bearings, pistons, cylinders and rings and is not covered under warranty. To avoid water condensation in the oil, periodically run the compressor with tank pressure near 150 psi for two-stage compressors or 120 psi for single stage compressors by opening the drain cock or an air valve connected to the tank or hose. Run the pump for an hour at a time at least once a week or more often if the condensation reoccurs.

IMPORTANT: Change oil after first 50 hours of operation.

Air Filter

Never run the compressor pump without an intake air filter or with a clogged intake air filter. The air filter element should be checked monthly (see Figure 10). Operating compressor with a dirty filter can cause high oil consumption and increase oil contamination in the discharge air. If the air filter is dirty it must be replaced.

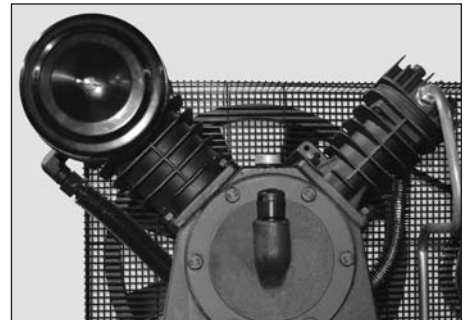

Figure 10

MAINTENANCE AND INSPECTION INSTRUCTIONS (CONTINUED)

Intercooler

⚠ CAUTION *Intercooler fins are sharp, always wear gloves and use care when you clean or work near the intercooler.*

Weekly, check the intercooler to be sure all fittings are secure and tight. Clean all dirt, dust and other accumulations from the intercooler fins.

Components

Turn off all power and clean the cylinder head, motor, fan blades, air lines, intercooler and tank on a monthly basis.

Belts

⚠ WARNING *Lock out and tag the power then release all pressure from the tank to prevent unexpected movement of the unit.*

Check belt tension every 3 months. Adjust belt tension to allow 3/8 inch to 1/2 inch deflection with normal thumb pressure. Also, align belts using a straight edge against the face of the flywheel and touching the rim on both sides of the face. The belts should be parallel to this straight edge (see Figure 11). Dimension A should be the same as B and C to ensure proper alignment of the belts.

Slots in the bed-plate allow for sliding the motor back and forth to adjust belt tension.

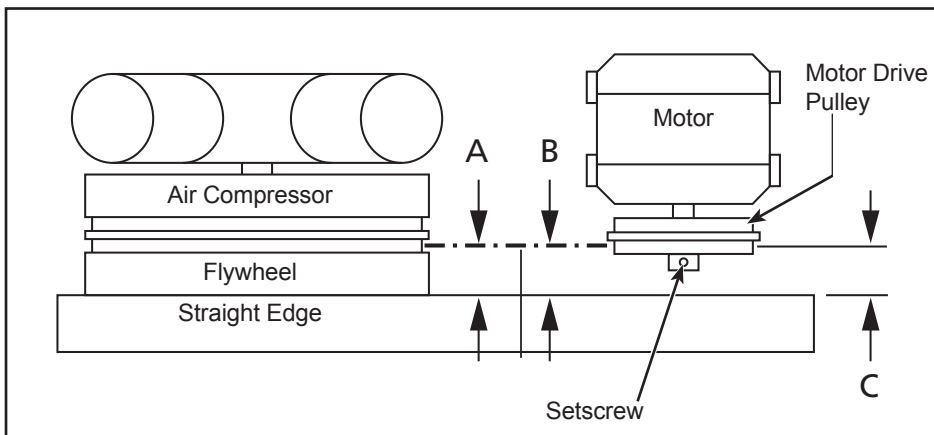
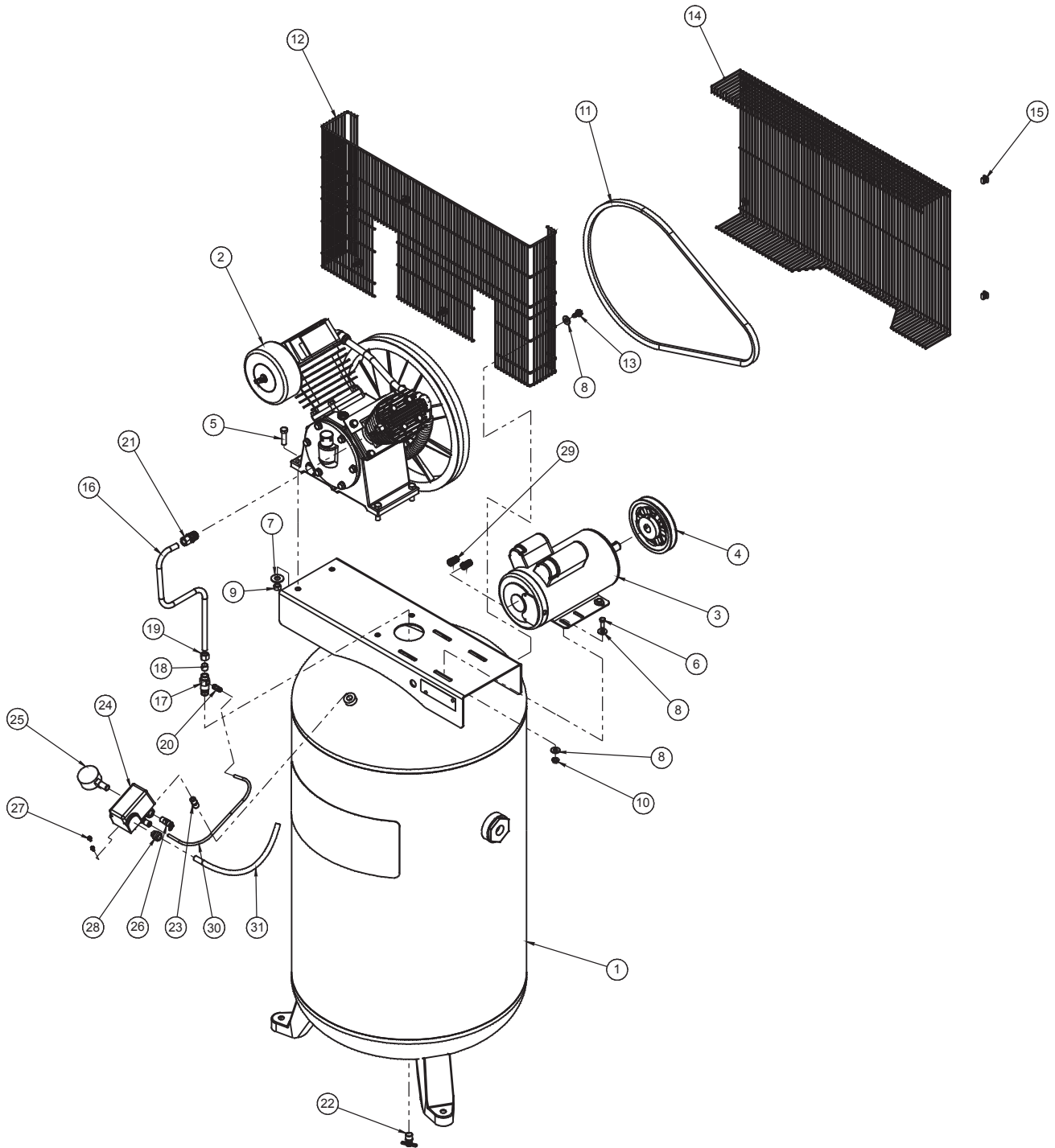

Figure 11 - Top View

Maintenance Schedule

Operation	Daily	Monthly	3 Months
Check Safety Valve	●		
Drain Tank	●		
Check Oil Level	●		
Clean or Change Air Filter		●	
Check Intercooler		●	
Clean Unit Components		●	
Check Belt Tightness			●
Change Oil (see Figure 6)			●

REPAIR PARTS ILLUSTRATION FOR JCP-801



Please provide following information:

- Model number
- Serial number (if any)
- Part description and number as shown in parts list

REPAIR PARTS LIST FOR JCP-801

Ref. No.	Description	Part Number:	Qty.
1	AIR RECEIVER, 80 GALLON VERTICAL	JCP801-001	1
2	COMPRESSOR PUMP, 5HP 2-STAGE	JCP801-002	1
3	MOTOR, 5HP 208-230V 1PH	JCP801-003	1
4	PULLEY, 5.7PD X 7/8 IN. BORE	JCP801-004	1
5	HEX HEAD CAP SCREW, 7/16 IN.-14 X 1.5 IN.	-	4
6	HEX HEAD CAP SCREW, 5/16 IN.-18 X 0.75 IN.	-	4
7	WASHER, 7/16 IN. (ID 0.5 IN. X OD 1.25 IN.)	-	4
8	WASHER, 5/16 IN. (ID 0.375 IN. X OD 0.875 IN.)	-	12
9	HEX NUT, 7/16 IN.-14	-	4
10	SPINLOCK NUT, 5/16 IN.-18	-	4
11	BELT, A62	-	1
12	BELT GUARD BACK	JCP801-005	1
13	SELF TAPPING HEX HEAD SCREW, 5/16 IN.-12	-	4
14	BELT GUARD FRONT	JCP801-006	1
15	BELT GUARD RETAINING CLIPS	JCP801-007	4
16	EXHAUST TUBE	JCP801-008	1
17	CHECK VALVE	JCP601-007	1
18	FERRULE, 1/2 IN.	-	1
19	COMPRESSION NUT, 1/2 IN.	-	1
20	QUICK CONNECT, 1/8 IN.NPT X 1/4 IN.TUBE	JCP601-008	1
21	COMPRESSION FITTING, 1/2 IN.	-	1
22	TANK DRAIN, 3/8 IN. NPT	JCP801-009	1
23	NIPPLE, 1/4 IN. NPT X 1.5 IN.	-	1
24	PRESSURE SWITCH	JCP801-010	1
25	GAUGE, 300PSI	JCP601-011	1
26	SAFETY VALVE, 200PSI	JCP801-011	1
27	SELF TAPPING HEX HEAD SCREW, #8-0.375 IN.	-	2
28	CORD STRAIN RELIEF	-	1
29	WIRE NUT, 18-10AWG	-	2
30	PTFE TUBE, 1/4 IN. X 13.5 IN.	-	1
31	MOTOR CORD	JCP601-018	1
Not Shown:			
32	GENERAL WARNING DECAL	LM000184	1
33	JET LOGO 7-1/4 IN.H X 17 IN.W	LM000173	1
34	ID LABEL JCP-801	LM000175	1
Optional:			
35	ISOLATOR PAD (SET OF 3)	JCP804-100	1

GETTING STARTED

SAFETY / SPECIFICATIONS

ASSEMBLY / INSTALLATION

OPERATION

TROUBLESHOOTING

MAINTENANCE / REPAIR

REPAIR PARTS ILLUSTRATION FOR JCP-801

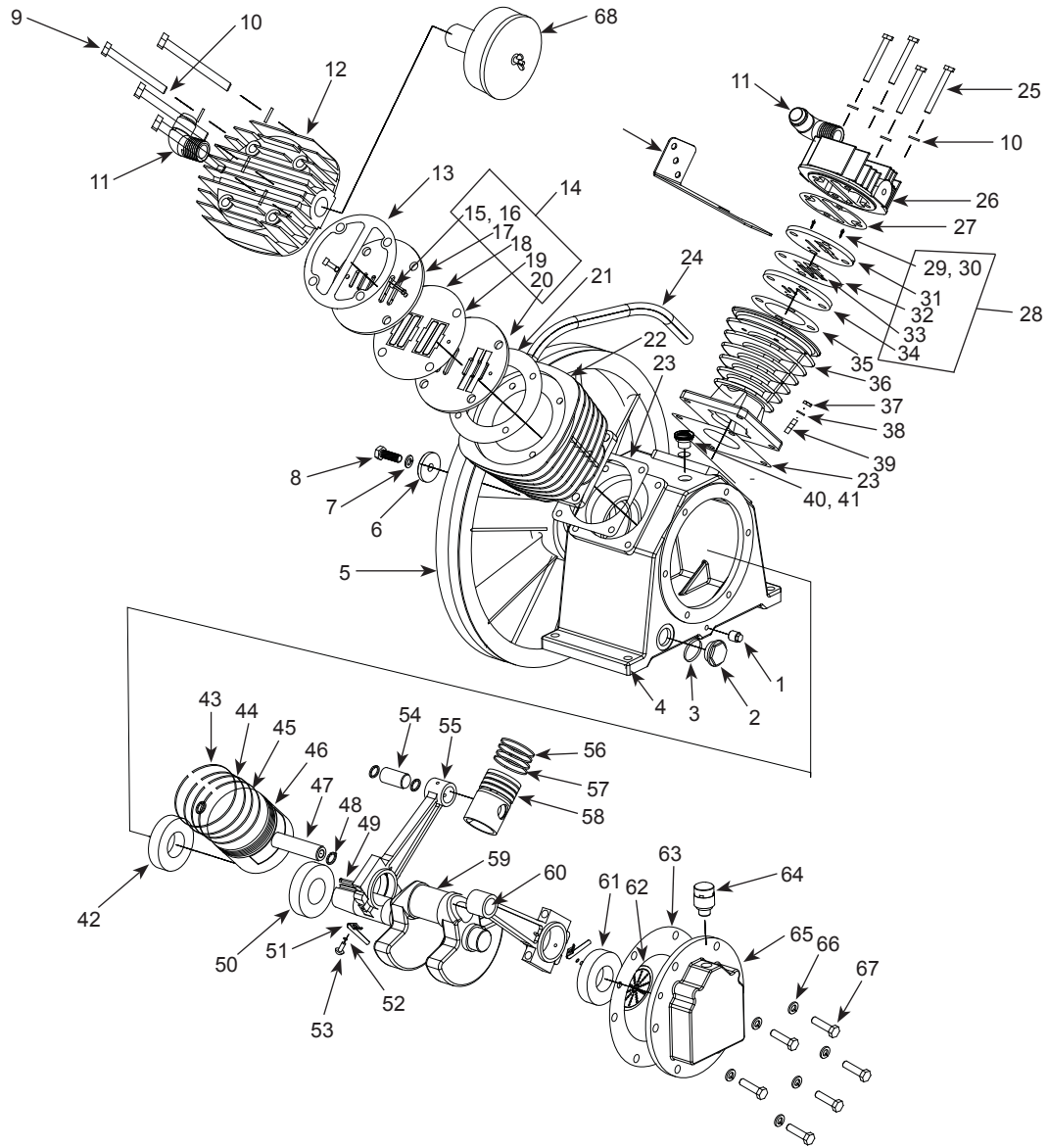

Please provide following information:

- Model number
- Serial number (if any)
- Part description and number as shown in parts list

REPAIR PARTS LIST FOR JCP-801

Ref No	Description	Part Number	Qty
1	1/4" NPT DRAIN PLUG	◆	1
2	OIL LEVEL GAUGE	◆ ▼	1
3	OIL LEVEL GAUGE O-RING	◆ ▼ ㇀	1
4	CRANKCASE	◆	1
5	FLYWHEEL	■	1
6	FLAT WASHER	▲ ❖	1
7	LOCK WASHER	▲ ❖	1
8	BOLT, M12	▲ ❖	1
9	HEX CAPSCREW, M10X80	❖	4
10	SPRING WASHER, M10	❖	8
11	INTERCOOLER FITTING WITHOUT TAPPED HOLE	--	2
12	CYLINDER HEAD (LOW PRESSURE)	㇀	1
13	HEAD GASKET (LP)	≠ ㇀	1
14	VALVE PLATE ASSEMBLY	≠	1
21	VALVE PLATE - CYLINDER GASKET (LP)	≠ ㇀	1
22	CYLINDER (LP)	--	1
23	CYLINDER-CRANKCASE GASKET	㇀	2
24	INTERCOOLER ASSEMBLY WITH FLARE NUTS	--	1
25	HEX BOLT, M10X65	❖	4
26	CYLINDER HEAD (HIGH PRESSURE)	--	1
27	HEAD GASKET (HP)	㇀ ☆	1
28	VALVE PLATE ASSEMBLY (HP)	☆	1
35	VALVE PLATE - CYLINDER GASKET (HP)	㇀ ☆	1
36	CYLINDER (HP)	--	1
37	NUT	❖	8
38	SPRING WASHER	❖	8
39	STUD BOLT	❖	8
40	FILL PLUG	◆ □	1
41	FILL PLUG O-RING	◆ □	1
42	OIL SEAL	◆ ㇀	1
43	COMPRESSION RING	‡	1
44	COMPRESSION RING	‡	1
45	OIL RING	‡	2
46	PISTON	‡‡	1
47	WRIST PIN	‡‡	1
48	RETAINER CLIP	‡‡ ○	2
49	KEY	■	1
50	BALL BEARING	●	1
51	DIPPER	★ †	1
52	LOCK WASHER	★ †	1
53	DIPPER RETAINING SCREW, M4X10	★ †	1
54	WRIST PIN	○	1
55	CONNECTING ROD	†	1
56	COMPRESSION RING	∞	3

Ref No	Description	Part Number	Qty
57	OIL RING	∞	1
58	PISTON	○	1
59	CRANKSHAFT	●	1
60	CONNECTING ROD (HP)	★	1
61	BALL BEARING	●	1
62	REAR BEARING PLATE	††	1
63	BEARING CAP GASKET	㇀	1
64	BREATHER ASSEMBLY	JCP801-012	1
65	BEARING CAP	††	1
66	COPPER WASHER	❖	1
67	BOLT	❖	1
68	AIR FILTER ASSEMBLY	JCP801-013	1
69	BELTGUARD BRACKET	JCP801-014	1

NOT SHOWN

AIR FILTER ELEMENT	JCP801-015	1
--------------------	------------	---

REPAIR KITS AND ACCESSORIES

▲	FLYWHEEL BOLT KIT	JCP801-016	1
■	FLYWHEEL WITH KEY	JCP801-017	1
●	CRANKSHAFT ASSEMBLY WITH BEARINGS	JCP801-018	1
◆	CRANKCASE ASSEMBLY WITH OIL SEAL, OIL LEVEL GAUGE, DRAIN PLUG, AND FILL PLUG	JCP801-019	1
▼	OIL LEVEL GAUGE WITH O-RING	JCP801-020	1
□	FILL PLUG WITH O-RING	JCP801-021	1
★	HIGH PRESSURE CONNECTING ROD ASSEMBLY WITH DIPPER	JCP801-022	1
†	LOW PRESSURE CONNECTING ROD ASSEMBLY WITH DIPPER	JCP801-023	1
††	BEARING CAP WITH BAFFLE	JCP801-024	1
‡	PISTON RING KIT (LP)	JCP801-025	1
‡‡	PISTON SET (LP)	JCP801-026	1
○	PISTON SET (HP)	JCP801-027	1
∞	PISTON RING KIT (HP)	JCP801-028	1
≠	VALVE PLATE KIT (LP)	JCP801-029	1
㇀	GASKET, OIL SEAL AND O-RING KIT (EXCEPT VALVE PLATE TO PLATE GASKET)	JCP801-030	1
❖	ASSEMBLY FASTENER SET	JCP801-031	1
☆	VALVE PLATE KIT (HP)	JCP801-032	1
--	NOT AVAILABLE		