

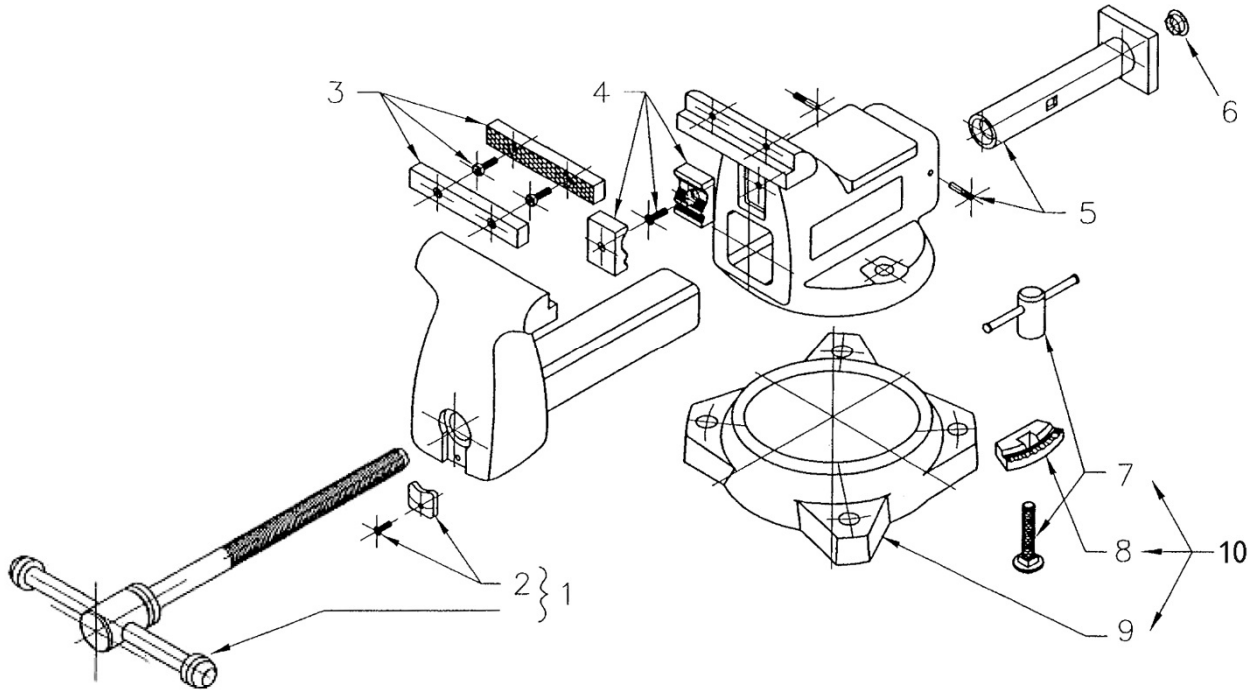

## #21400, Mechanics' Vise (model 745A)



### Replacement parts

Spindle and Handle Assembly #1	Spindle Retainer w/ screw #2	Jaw Insert Assembly w/ four screws #3	Pipe Jaws w/ two screws #4	Casing Nut w/ two pins #5	End Plug #6	Lock Nut Assembly #7	Locking Pads (pair) #8	Outer Ring only #9	Swivel Base Assembly, Complete #10
21400-01	21400-02	21400-03	21400-04	21400-05	NA	21400-06	9040020	1011980	21400-07

Having the Model Number and Serial Number of your tool available when you call will allow us to serve you quickly and accurately. Some parts are shown for reference only, and may not be available individually.

### Specifications

Stock no.	<b>21400</b>
Model no.	745A
Jaw width (in.)	5
aMaximum opening (in.)	5-1/4
Throat depth (in.)	3-3/4
Pipe jaw capacity (in.)	1/4 – 2-1/2
Net weight, approx. (lbs.)	52.8

**Note: See reverse side for important safety instructions.**



## IMPORTANT SAFETY INSTRUCTIONS

- Misuse of vise can cause serious injury to eyes, hands, limbs, etc.
- To ensure safety, vise must be set up and used properly.
- Before setting up and using, read, understand, and follow all instructions as outlined below.

When setting up vise:

- Use proper size bolts, nuts, lock and flat washers, in all base mounting Holes. Never weld base of vise to any metal object.
- Only hand-tighten swivel base lock down nuts at the sides of the vise.
- Never use a pipe extension to tighten lock nut handles; this can cause the handles to bend and overstress the lock down bolts.
- Make sure the bench top to which the vise is mounted is properly secured.

When using vise:

- Always use vise of proper size and capacity to hold work object.
- Never use a hammer, pipe extension or cheater bar on spindle handle of vise.
- Never unscrew moveable jaw beyond the maximum specified opening of the vise.
- Never use vise as a press for assembly or disassembly of objects.
- Always wear eye and face protection when striking vise-held objects or when using power tools with a vise.
- NOTE: The spindle handle ("tommy bar") has been engineered to bend if excessive clamping pressure is applied, to prevent potential damage to vise.



## Bench Vise Mounting Dimensions

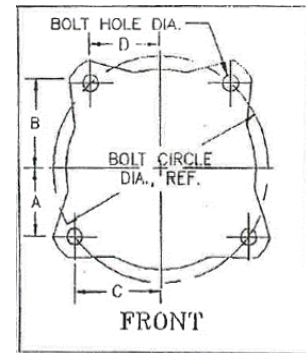

	Stock No.	Model	Base Part No.	Dimension A (in)	Dimension B (in)	Dimension C (in)	Dimension D (in)	Bolt Circle Diameter (in)	Bolt Hole Diameter (in)	Mounting Bolt Diameter (in)
Mechanics Pro	28810	845M	744M-06	2 7/16"	2 14/16"	2 14/16"	2 7/16"	7 8/16"	1/2"	7/16"
	28811	855M	745M-06	2 13/16"	3 6/16"	3 6/16"	2 13/16"	8 12/16"	1/2"	7/16"
	28812	865M	745M-06	2 13/16"	3 6/16"	3 6/16"	2 13/16"	8 12/16"	1/2"	7/16"
	28813	880M	748M-06	3 5/16"	3 15/16"	3 15/16"	3 5/16"	10 5/16"	11/16"	5/8"
	28814	8100M	748M-06	3 5/16"	3 15/16"	3 15/16"	3 5/16"	10 5/16"	11/16"	5/8"
Mechanics	21300	744	21300-09	2 3/16"	2 14/16"	3 1/16"	2 7/16"	7 8/16"	9/16"	1/2"
	21400	745	1011980	2 9/16"	3 5/16"	3 9/16"	2 13/16"	8 12/16"	11/16"	5/8"
	21500	746	21500-09	2 13/16"	3 12/16"	4 "	3 2/16"	9 12/16"	11/16"	5/8"
	21800	748	1010840	2 13/16"	3 12/16"	4 "	3 2/16"	9 12/16"	11/16"	5/8"
	63187	1550/745 YEL.	1012060	2 9/16"	3 5/16"	3 9/16"	2 13/16"	8 12/16"	11/16"	5/8"
	63188	1560/746 YEL.	1013060	2 13/16"	3 12/16"	4 "	3 2/16"	9 12/16"	11/16"	5/8"
Shop	63300	WS4	310046WA	2 4/16"	2 4/16"	2 4/16"	2 4/16"	6 5/16"	9/16"	1/2"
	63301	WS5	310056WA	2 8/16"	2 8/16"	2 8/16"	2 8/16"	7 "	9/16"	1/2"
	63302	WS6	310066WA	2 11/16"	2 11/16"	2 11/16"	2 11/16"	7 9/16"	9/16"	1/2"
	63304	WS8	310086WA	3 2/16"	3 2/16"	3 2/16"	3 2/16"	8 13/16"	9/16"	1/2"
Utility / Utility HD	28818	674U	674U-05	1 14/16"	2 4/16"	2 4/16"	1 14/16"	5 14/16"	7/16"	3/8"
	28819	675U	675U-05	2 1/16"	2 8/16"	2 8/16"	2 1/16"	6 7/16"	1/2"	7/16"
	28820	676U	744M-06	2 7/16"	2 14/16"	2 14/16"	2 7/16"	7 8/16"	1/2"	7/16"
	28815	656UHD	656W-05	3 2/16"	3 11/16"	3 11/16"	3 2/16"	9 11/16"	1/2"	7/16"
	28816	648UHD	648W-05	3 2/16"	3 12/16"	3 12/16"	3 2/16"	9 12/16"	11/16"	5/8"
	11126	D4/674	2900710	2 "	2 "	2 3/16"	1 13/16"	NA	7/16"	3/8"
	11127	D5/675	2900720	2 1/16"	2 1/16"	2 8/16"	2 "	NA	7/16"	3/8"
	11128	D6/676	2900730	2 7/16"	2 7/16"	2 14/16"	2 5/16"	NA	7/16"	3/8"
	191	656	2656002	3 8/16"	3 8/16"	3 8/16"	3 8/16"	10 "	5/8"	1/2"
11800	648	2648004	3 7/16"	3 7/16"	3 7/16"	3 7/16"	9 12/16"	11/16"	5/8"	
Reversible	28821	4550R	4500R-04	2 13/16"	3 6/16"	3 6/16"	2 13/16"	8 12/16"	1/2"	7/16"
	28822	4650R	4600R-03	2 13/16"	3 6/16"	3 6/16"	2 13/16"	8 12/16"	1/2"	7/16"
	28823	4800R	4800R-04	3 "	3 9/16"	3 9/16"	3 "	9 4/16"	9/16"	1/2"
	14500	4500	11206S03	3 2/16"	3 2/16"	3 2/16"	3 2/16"	8 14/16"	9/16"	1/2"
	14600	4600	11206S03	3 2/16"	3 2/16"	3 2/16"	3 2/16"	8 14/16"	9/16"	1/2"
	14800	4800	14800S07	3 2/16"	3 2/16"	3 2/16"	3 2/16"	8 13/16"	9/16"	1/2"
Multi-Purpose	28824	550P	550P-07	2 2/16"	2 9/16"	2 9/16"	2 2/16"	6 11/16"	1/2"	7/16"
	69999	Multi-Purpose 5	n/a	2 7/16"	2 7/16"	2 7/16"	2 7/16"	6 14/16"	1/2"	7/16"
General Purpose	11104	89100	NA	2 9/16"	2 9/16"	2 9/16"	2 9/16"	5 2/16"	3/8"	5/16"
	11105	89125	NA	3 5/16"	3 5/16"	3 5/16"	3 5/16"	6 10/16"	7/16"	3/8"
	11106	89150	NA	3 14/16"	3 14/16"	3 14/16"	3 14/16"	7 12/16"	1/2"	7/16"