



Model no.:	Stock no.:
Serial no.:	
Purchased from:	
Date purchased:	Date in service:

Operating Instructions and Parts Manual PTJ Series Pallet Trucks



Part No. M-151003
Revision C1 09/2018
Copyright © 2017 JET



3.0 IMPORTANT SAFETY INSTRUCTIONS

1. Read and understand the entire owner's manual before attempting assembly or operation of the pallet truck.
2. Read and understand the warnings on the pallet truck and in this manual. Failure to comply with all of these warnings may cause serious injury.
3. Replace the warning labels if they become obscured or removed.
4. Do not use this pallet truck for other than its intended use. If used for other purposes, JET disclaims any real or implied warranty and holds itself harmless from any injury that may result from that use.
5. Do not place hands or feet under the pallet truck at any time.
6. Do not operate a loaded pallet truck on ramps or inclines.
7. Do not tip load pallet truck forks. This may cause damage to the forks and personal injury if the rear of the pallet truck suddenly pops up.
8. Never leave a loaded pallet truck unattended in the raised position. Always lower load to the floor.
9. Do not load pallet truck beyond its rated capacity of 5,000 lbs.
10. Secure load before transporting.
11. To prevent accidental tipping, make sure load is centered on the forks.
12. Do not move a loaded pallet truck by other than manual force.
13. **⚠️WARNING:** This product can expose you to chemicals including lead and cadmium which are known to the State of California to cause cancer and birth defects or other reproductive harm, and phthalates which are known to the State of California to cause birth defects or other reproductive harm.

4.0 Introduction

To better understand the proper use and safe operation of this pallet truck, please take a few minutes to carefully read and follow the instructions in this manual. When finished reading and understanding the manual, please file in a safe and convenient location for the life of the pallet truck. If the pallet truck transfers ownership, the manual should accompany it.

This pallet truck is designed to push and pull palletized material loads up to 5,000 pounds only.

You will notice several important features about your JET Pallet Truck. For example, its 2-1/2" lowered height and tapered fork tips allow easy entry into pallets. The heavy-gauge steel frame is reinforced with cross-welded steel plates to prevent forks from bending and solid steel push rods are used for added strength. The pump features top-of-the-stroke and overload by-pass valve systems. A durable powder coat finish provides long lasting steel protection. Extra wide polyurethane covered steel steer wheels and nylon load wheels feature lifetime lubricated, double sealed bearings to provide smooth, quiet rolling and added stability.

If there are questions or comments, please contact your local supplier or JET.

5.0 Specifications

Force required to pump at maximum load 89 lbs.
 Force required to move at maximum load..... 110 lbs.
 Handle cycles to maximum height 8
 Ram/pump piston outside diameter 1.18 / 0.71 in.

Model #	Stock #	W1	W2	L1	L2	H1	H2	A (dxw)	B (dxw)	C	Net Wt. (lb.)
PT-1636J	151003	16"	6"	36"	51"	6-1/4"	2-1/2"	6-1/4"x2-3/4"	2-1/2"x3-3/4"	45-1/8"	135
PT-2036J	151004	20-1/2"	6"	36"	51"	6-1/4"	2-1/2"	6-1/4"x2-3/4"	2-1/2"x3-3/4"	45-1/8"	150
PT-2042J	151005	20-1/2"	6"	42"	57"	6-1/4"	2-1/2"	6-1/4"x2-3/4"	2-1/2"x3-3/4"	45-1/8"	161
PT-2048J	151006	20-1/2"	6"	48"	63"	6-1/4"	2-1/2"	6-1/4"x2-3/4"	2-1/2"x3-3/4"	45-1/8"	172
PT-2742J	151008	27"	6"	42"	57"	6-1/4"	2-1/2"	6-1/4"x2-3/4"	2-1/2"x3-3/4"	45-1/8"	185
PT-2748J	151009	27"	6"	48"	63"	6-1/4"	2-1/2"	6-1/4"x2-3/4"	2-1/2"x3-3/4"	45-1/8"	196

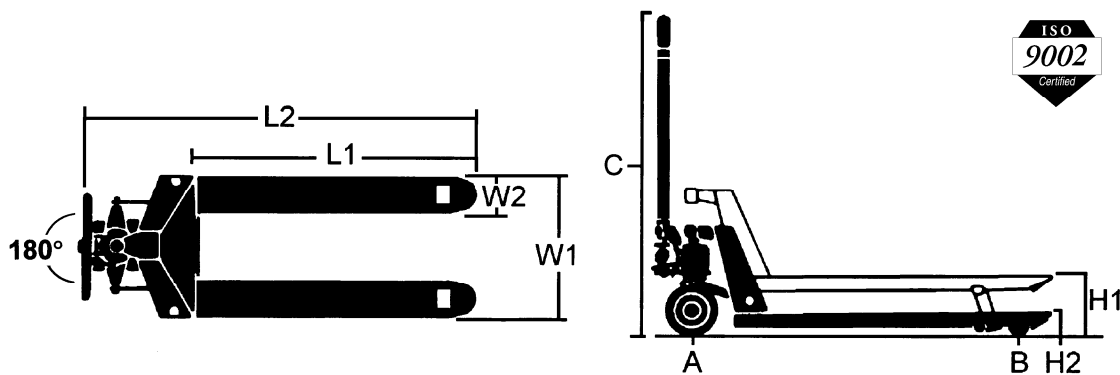

Figure 1

The specifications in this manual were current at time of publication, but because of our policy of continuous improvement, JET reserves the right to change specifications at any time and without prior notice, without incurring obligations.

6.0 Setup and assembly

Note: Pallet trucks are available individually or in crate quantities (6 units to a crate). If purchased in crate quantity, match the “number” label on the handle to the “number” label on the frame, prior to assembly. Proceed with instructions below.

Tools Needed for Assembly

- Hammer
- Flat Head Screwdriver
- Pliers or 17mm Wrench

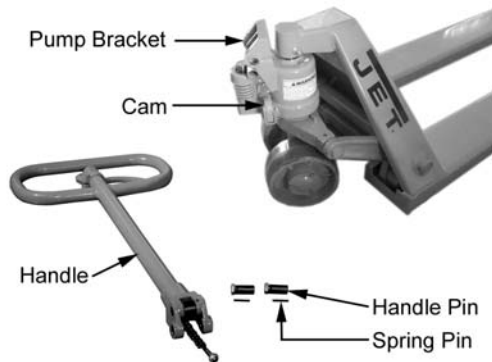

Figure 1

1. Insert the base of the handle (A, Figure 2) into the pump bracket (B, Figure 2).
2. Align the holes (C, Figure 2) at the base of the handle with the holes in the pump bracket.
3. Using a screwdriver, pry the cam (D, Figure 2) up and slip the bolt head under the notch in the cam. **Do not adjust the nut.**

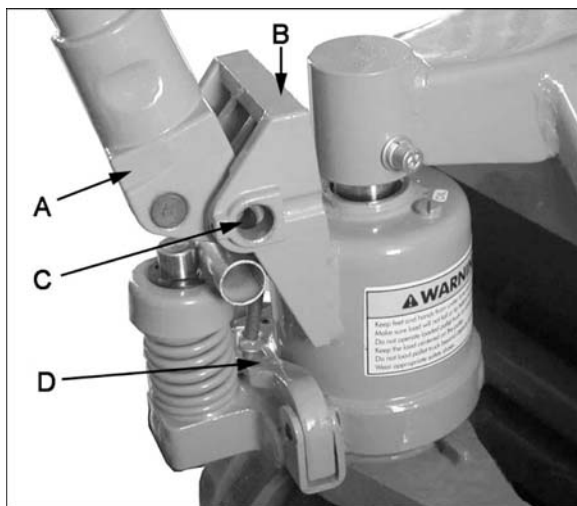

Figure 2

4. Insert handle pins (E, Figure 3) into the holes of the pump bracket and handle. Align the spring pin holes (F, Figure 3) in the handle pin and the pump bracket.
5. Tap the handle pins into place with a hammer.

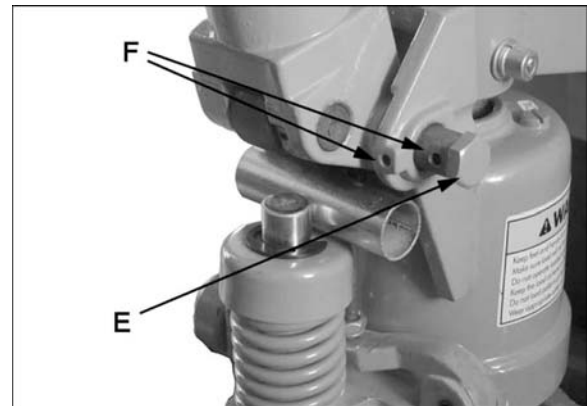

Figure 3

6. Using a hammer, tap the spring pins (A, Figure 4) into the pump bracket and handle pins.
- Note:** If the holes aren't lined up, use a 17mm wrench or pliers to turn the handle pin until the spring pin holes line up.
7. Repeat for the opposite side handle pin.
 8. Pull handle down and remove retaining tube (B, Figure 4) by pulling straight out. Discard retaining tube.

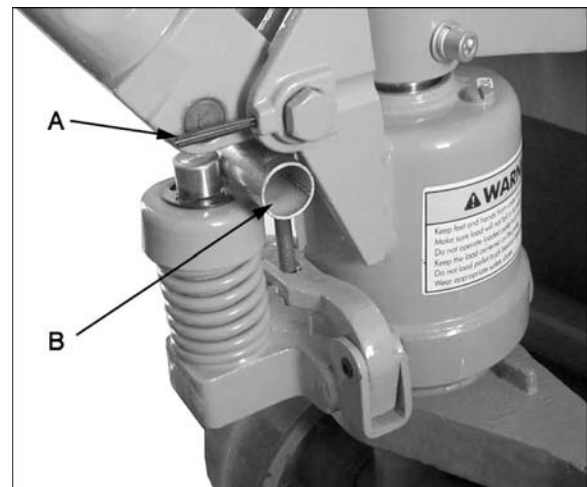

Figure 4

Note: If the pallet truck does not raise or lower properly, you may have air bubbles in the pump from shipping. Refer to *section 8.1 – Cleaning Release Valve*.

7.0 Operations

To raise forks, place handle in the UP position (bottom part of the handle slot), See Figure 5.

To lower forks, pull lever handle to DOWN position (upper part of slot).

To freely move the handle, set lever in Neutral (center notch of slot).

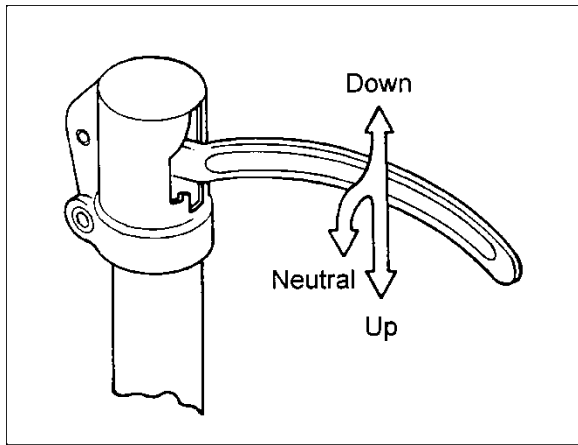

Figure 5

7.1 Lifting Load

1. Lower forks to lowest position, Figure 5.
2. Insert forks under load, or into pallet.
3. Place lever in UP position (bottom part of slot), Figure 5.
4. Move handle up and down until forks reach desired height.

7.2 Moving Load

1. Place lever in NEUTRAL position (center notch of slot), Figure 5.
2. Pull or push pallet truck to desired location.

7.3 Lowering Load

1. Pull lever to DOWN position (upper part of slot), Figure 5.
2. Pull forks away from load.

7.4 Up-Down Cam Adjustment

1. Set lever in NEUTRAL position, Figure 5.
2. Turn cam nut while pumping the handle, Figure 6.
3. When lifting stops, give the nut one more turn.
4. The cam nut is properly adjusted when pumping the handle in NEUTRAL position causes no movement of the hydraulic ram.

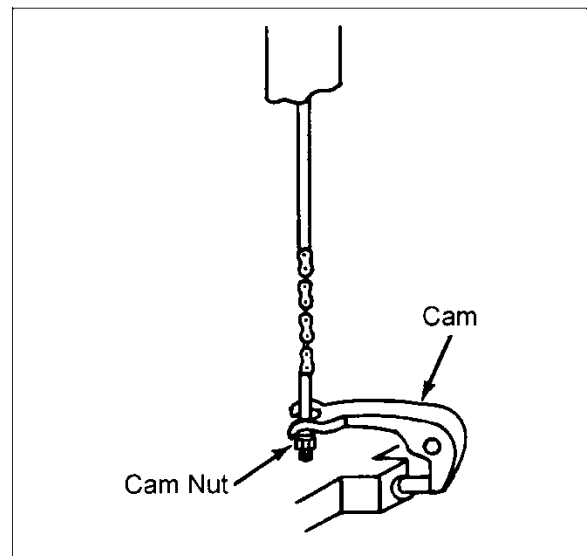

Figure 6

8.0 Maintenance

8.1 Cleaning Release Valve

Over time, the hydraulic pump assembly may become clogged with debris or air bubbles, and not function properly.

To clean the release valve and bleed the pump:

1. Pump handle quickly, raising pallet truck to full extent. While continuing pumping action, pull lever to down position.
2. When forks reach total down position, valve is flushed. Repeat if necessary.

8.2 Lubrication

Check oil level annually by removing oil plug found on top of pump housing. When changing or adding oil, fill the tank through the oil plug screw hole to 80% capacity with hydraulic jack oil, about 2" deep in pump housing, see Figure 7. **Do not** use any other type of oil.

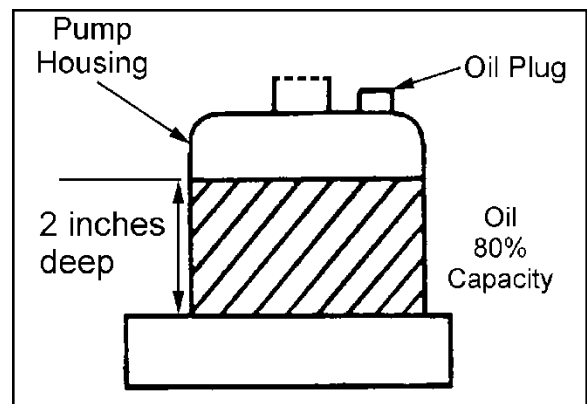

Figure 7

There is one grease fitting (#55B, section 10.1.1) located on the table. Lubricate this point on a semi-annual basis.

Wheel bearings are sealed and require no lubrication. The crank shaft features Oil Lite bushings which also require no lubrication.

Lightly oil all other moving parts.

8.3 Piston Seal/O-Ring Replacement

1. Raise pallet truck by pumping handle.
2. Remove screws #70, sect. 10.1.1. This will free the pump and handle assembly from the pallet truck.
3. Empty the oil into a suitable container. Pump handle until all oil has drained. Dispose of used hydraulic oil or fluid according to local regulations.
4. Pull out piston plunger #33, and/or ram piston #25.
5. Remove all o-rings and seals (see Figure 8).

6. Insert new o-ring or seal one at a time making sure to replace with the same size that was removed.
7. Reassemble and fill oil tank through the oil plug screw hole to 80% capacity with new hydraulic jack oil, about 2" deep in pump housing, see Figure 7.

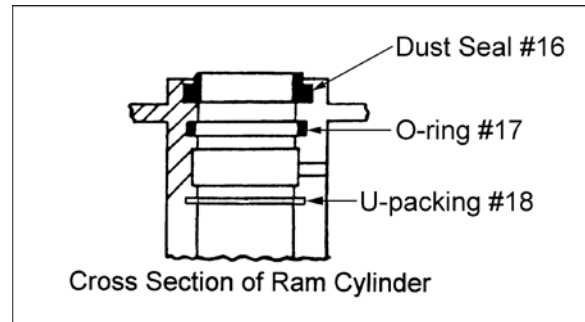

Figure 8

9.0 Troubleshooting the PTJ Series Pallet Trucks

Index numbers refer to parts breakdown, *section 10.0*.

Symptom	Possible Cause	Correction
Hydraulic unit does not lift.	Oil low in tank.	Make sure there is no oil leakage from Release Plug #36, and add oil.
	Air in pump.	Place lever in down position and pump handle repeatedly.
	Worn O-ring in cylinder.	Consult authorized service center.
Once lifted, truck lowers by itself.	Steel ball not seated in hydraulic unit.	Refer to <i>section 8.1 Cleaning Release Valve</i> .
	Worn O-ring in cylinder.	Consult authorized service center.
	Release valve not seated properly.	Refer to <i>section 8.1 Cleaning Release Valve</i> .
	Oil leakage from Release Plug #36.	Tighten Release Plug #36. Replace O-rings on Release Plug #36. If leakage still occurs, consult authorized service center.
Fork does not lower.	Cam #53 broken.	Replace cam #53.
	Up-down cam nut #15 out of adjustment.	Refer to <i>section 7.4 Up-Down Cam Adjustment</i> .
	Broken fork rods and linkage.	Consult authorized service center, or replace broken parts.
Lever does not set at NEUTRAL position.	Up-down cam nut #15 out of adjustment.	Refer to <i>section 7.4 Up-Down Cam Adjustment</i> .

10.0 Replacement Parts

Replacement parts are listed on the following pages. Having the Model Number and Serial Number of your machine available when you call will allow us to serve you quickly and accurately.

Non-proprietary parts, such as fasteners, can be found at local hardware stores, or may be ordered from JET. Some parts are shown for reference only, and may not be available individually.

10.1.1 PTJ-Series Pallet Trucks – Exploded View

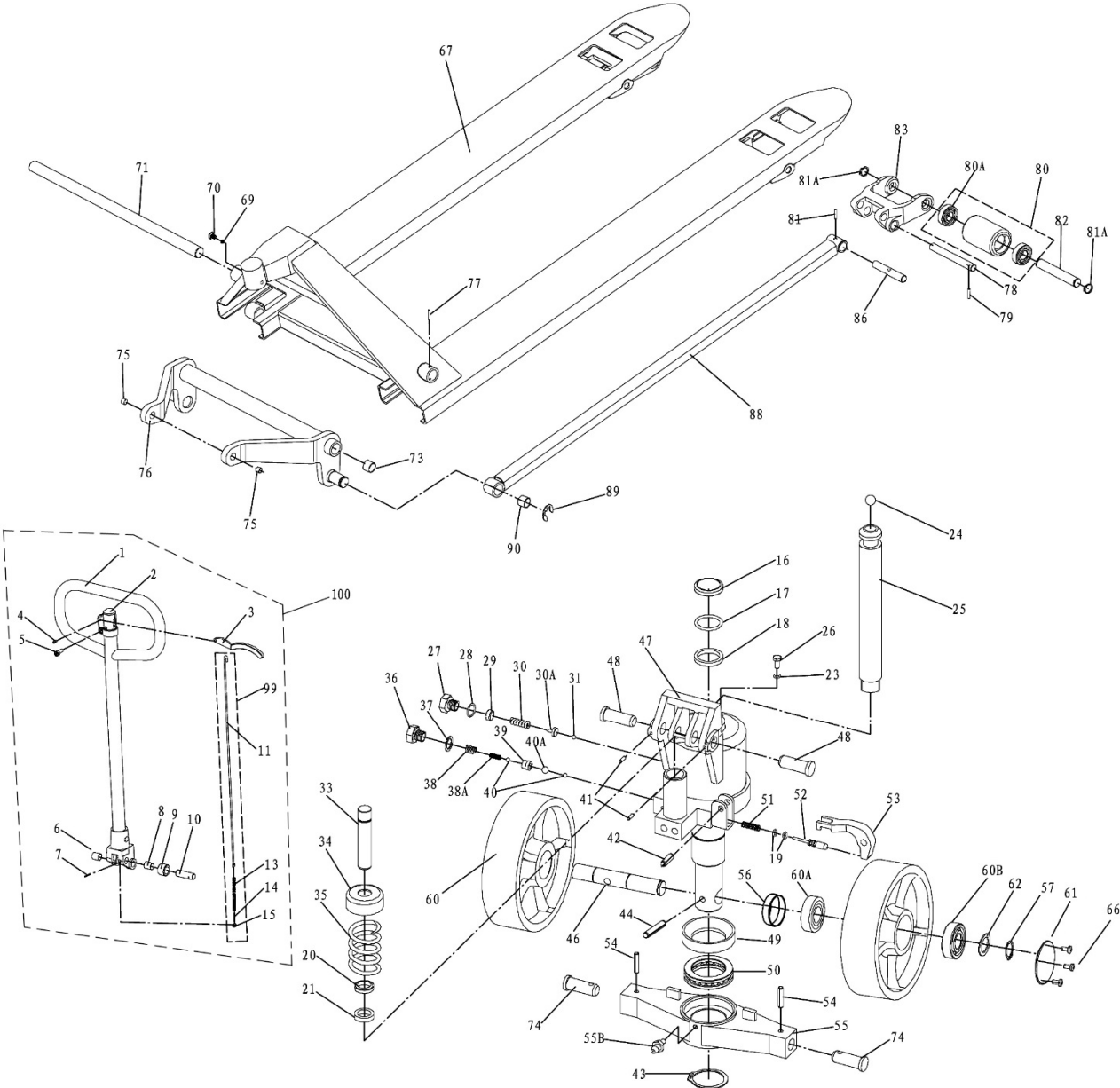

10.1.2 PTJ-Series Pallet Trucks – Parts List

Index No	Part No	Description	Size	Qty
1	PT2748A-001A	Handle		1
2	PT2748A-002A	Handle Cap		1
3	PT2748A-003A	Lever		1
4	PT2748A-004	Spring Pin	5x16mm	1
5	PT2748A-005	Bolt	M8x20	1
6	PT2748A-006	Oil Lite Bushing		2
7	PT2748A-007	Spring Pin	3x28mm	1
8	PT2748A-008	Oil Lite Bushing		1
9	PT2748A-009	Roller		1
10	PT2748A-010	Roller Pin		1
11	PT2748A-011	Release Rod		1
13	PT2748A-013	Chain		1
14	PT2748A-014	Anchor Bolt		1
15	PT2748A-015	V-Nut	M8	1
16	PT2748J-101B-1	Dust Seal *		1
17	PT2748J-101B-2	O-Ring *	29.8x3.5mm	1
18	PT2748J-101B-3	U-Packing *	30x38x6mm	1
19	PT2748J-101B-4	O-Ring *	4.8x1.9mm	2
20	PT2748J-101B-5	Dust Seal *		1
21	PT2748J-101B-6	U-Packing *	18x26x5	1
23	PT2748J-101B-7	O-Ring *	6x1.9mm	1
24	SB-14MM	Steel Ball	14mm	1
25	PT2748J-025	Ram Piston		1
26	PT2748A-026	Oil Plug		1
27	PT2748A-027	Pressure Adjust Screw		1
28	PT2748J-101B-8	O-Ring *	11.8x2.65mm	1
29	PT2748A-029	Release Screw		1
30	PT2748A-030	Spring	10x2.3x27mm	1
30A	PT2748A-30A	Valve		1
31	SB-6MM	Steel Ball	6mm	1
33	WPT2748L-033	Plunger Piston		1
34	PT2748A-034	Spring Cap		1
35	WPT2748A-035	Spring	38x5x113mm	1
36	PT2748A-036	Release Plug		1
37	PT2748A-037	Washer *	20mm	1
38	PT2748A-038	Spring	8x1.5x12.8mm	1
38A	PT2748A-038A	Spring	4.8x0.7x15mm	1
39	PT2748A-039	Valve Housing		1
40	SB-6MM	Steel Ball	6mm	2
40A	SB-9MM	Steel Ball	9mm	1
41	PTX2748-002	Spring Pin	4x30mm	2
42	PT2748A-042	Spring Pin	8x25mm	1
43	PT2748A-043	Snap Ring	44mm	1
44	WPT2748A-044A	Spring Pin	8x40mm	1
46	PT2748A-046A	Wheel Shaft (<i>all models except PT-1636J</i>)		1
	WPT1636J-046A	Wheel Shaft (<i>PT-1636J only</i>)		1
47	WPT2748J-109A	Pump Housing Assembly (<i>all models</i>)		1
48	PT2748A-048	Handle Pin		2
49	PT2748A-049	Bearing Base		1
50	BB-51109	Ball Bearing	51109	1
51	PT2748A-051	Spring	6.3x1.2x25mm	1
52	PT2748A-052	Release Nozzle		1
53	PT2748A-053A	Cam		1
54	PT1636J-054	Spring Pin	6x30mm	2
55	WPT2748A-055	Table (<i>all models except PT-1636J</i>)		1
	WPT1636J-055	Table (<i>PT-1636J only</i>)		1
55B	PT2748A-055B	Grease Fitting		1
56	WPT2748A-056	Bearing Cap		2

* Available only in the repair kit, WPT2748J-101A

Index No	Part No	Description	Size	Qty
57	PT2748A-057	Snap Ring	20mm	2
60	PT2748L-103	Steer Wheel Assembly W/Bearings		2
60A	BB-6205VV	Steer Wheel Ball Bearing	6205VV	2
60B	BB-6304VV	Steer Wheel Ball Bearing	6304VV	2
61	PT2748A-061	Dust Seal Cap		2
62	TS-1550111	Washer	20mm	2
66	TS-2284082	Pan Head Machine Screw	M4x8	6
67		Fork Frame (N/A)		1
69	TS-1551061	Lock Washer	8mm	2
70	TS-1504031	Socket Head Cap Screw	M8x14	2
71	PT2748A-071	Crank Shaft (PT-2742J / PT-2748J)		1
	PT2048A-071	Crank Shaft (PT-2036J / PT-2042J / PT-2048J)		1
	PT1636J-071	Crank Shaft (PT-1636J Only)		1
73	PT2748J-073	Oil Lite Bushing (PT-2748J Only)		2
	PT2048J-073	Oil Lite Bushing (all models except PT-2742J/PT-2748J)		2
74	PT2748A-074	Table Pin		2
75	PT2748A-075	Oil Lite Bushing		2
76	PT2748J-076A	Lifting Yoke (PT-2742J / PT-2748J)		1
	PT2048J-076A	Lifting Yoke (PT-2036J / PT-2042J / PT-2048J)		1
	PT1636J-076A	Lifting Yoke (PT-1636J Only)		1
77	PT2748J-077	Spring Pin	6x35mm	1
78	WPT2748J-078	Arm Pin	16x145mm	2
79	WPT2748J-079	Spring Pin	5x25mm	2
80	PT2748J-080BN	Black Nylon Load Wheel W/Bearings		2
80A	BB-6004VV	Load Wheel Bearing	6004	4
81	WPT2748J-079	Spring Pin	5x25mm	2
81A	PT2748J-081A	Snap-Ring	20mm	4
82	PT2748J-082	Load Wheel Axle		2
83	WPT2748J-083	Load Wheel Frame		2
86	WPT2748J-086	Rod Pin	16x96mm	2
88	WPT2736J-088	Rod (PT-1636J / PT-2036J)		2
	WPT2742J-088	Rod (PT-2042J / PT-2742J)		2
	WPT2748J-088	Rod (PT-2048J / PT-2748J)		2
89	PT2748A-089A	E-Ring	19mm	2
90	PT2748A-090	Bushing		2
99	PT2748A-099	Release Rod Assembly (index #11,13-15)		1
100	PT2748J-HA	Handle Assembly (includes #1-10, 99)		1
	WPT2748J-101A	Repair Kit (index # 16-21, 23,28)		1
	PT2748J-109B	Pump Assembly (all models except PT-1636J)		1
	PT1636J-109A	Pump Assembly (PT-1636J only)		1
	WPT2748J-110	Pump, Handle, Wheel Assembly (all models except PT-1636J)		1
	WPT1636J-110	Pump, Handle, Wheel Assembly (PT-1636J Only)		1
	PT1636J-ID-A	I.D. Label (not shown)		1
	PT2036J-ID-A	I.D. Label (not shown)		1
	PT2042J-ID-A	I.D. Label (not shown)		1
	PT2048J-ID-A	I.D. Label (not shown)		1
	PT2742J-ID-A	I.D. Label (not shown)		1
	PT2748J-ID-A	I.D. Label (not shown)		1
	PT2748J-JET	JET Logo Label (not shown)		2
	PT2748J-WL	Warning Label (not shown)		1
	PT2748J-PL	Pump Label (not shown)		1

