

REF	PART	DESCRIPTION	REF	PART	DESCRIPTION
1	13-1110	Stand Upright	8		Screw #8 Hex Head Slotted
2	13-1120	Stand Upright (Crimped)	14-2550		SRS-C Set of Casters
3	13-1102	Stand Base Crossbar	9	14-2555	Cross Arm Assembly
4	13-1100	Stand Leg (left)	10	13-1090	1/4-20 x 9/16" Male Knob
4	13-1101	Stand Leg (right)	11,12	13-1095	Tab Washer w/ Female Knob
5		Stand Frame Bolt 3/8-16 x 3/4"	13	13-1150	Ceramic Socket
6	13-1135	Caster (ea.)	14	13-1180	Power Cord 120V
	13-1140	Stand Hardware Set		13-1160	On/Off Switch
7		Upright Fastener 5/16-18		13-1190	Hardware Set

Uses seven 250 watt R40 infrared bulbs. Not included.

ASSEMBLING YOUR NEW SYSTEM

Unpack Your System: Carefully unpack your new system, making sure all parts for assembly are included. If any parts are missing, call customer service for replacement.

Assemble Stand: Install casters and end caps first, then slide together legs and crossbar. Bolt H-frame parts together with supplied 3/8" bolts (5). Assemble upright by sliding crimped (2) and uncrimped (1) sections together and inserting lock screw. With the stand sitting upright on its casters, insert upright and secure with supplied 5/16" fasteners (7).

Final Assembly: Attach cross arm (9) to heater housing with supplied tab washer (11) and knob (12). Install vertical slid locking knob (10) to cross arm and slide assembly onto upright post on stand; secure at desired position with locking knob.

Install Bulbs: After installing heater-housing on stand upright, gently screw into place seven R40 120 volt 250 watt bulbs (not supplied with system). Bulbs should be tightened snugly.

First Use: Your Infratech curing system is ready for use. Only plug into a grounded power source. Position the system 18" or more away from the area to be cured.

WARNINGS:

NEVER block front of heater

DO NOT operate within 25' of flammable materials

DANGER: to reduce risk of explosion do not use within 10' of spraying operations while spraying

NEVER service heater without disconnecting from power Source of possible shock

Use only with grounded power source

Use only grounded extension cords that are rated for the amp load of the units

OPERATING TIPS

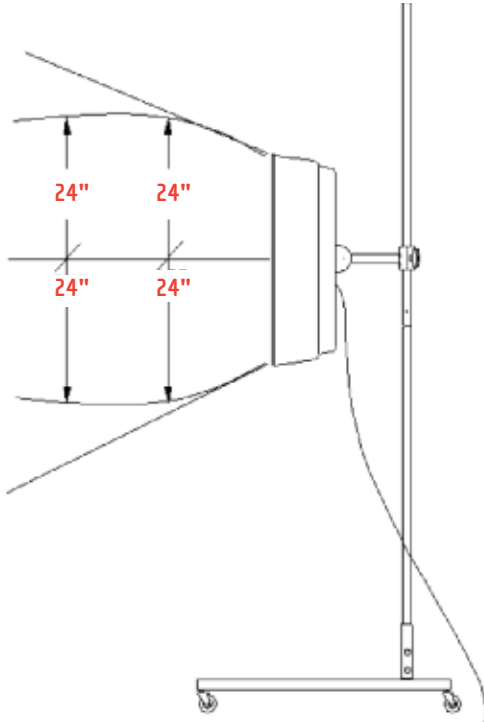

Your new Infratech infrared (IR) curing system provides fast, efficient curing for virtually every type of paint, primer, body filler, bonding adhesive and plastic repair product. Infratech infrared heats from the inside out, providing the best possible cure. It does not heat the air. IR cures by heating the coating and panel for the prescribed time to effect solvent evacuating and cross linking; the cure cycle is complete after the heated area cools back to room temperature. Once this full cycle is complete, the coating is fully cured and final assembly or cleanup for delivery can start. Care should be taken when using your new system. Operating the system too close to the part being cured can cause damage. When you first use your system, start at a distance of 24" to 30". As you gain experience using your system, you may be able to move the system closer (18" min. distance) to apply more heat and speed the curing cycle. Infratech heaters are powerful enough to blister paint and melt plastic. Additionally, it should be noted that different colors absorb IR at different rates.

CURING TIME

ITEM	DISTANCE FROM SURFACE	COVERAGE (H x W)	CURING TIME
2 K Primers	18"	2' x 2'	8-12 minutes
Waterborne Base Coat	18"	2' x 2'	6-10 minutes
Filler / Stoppers	18"	2' x 2'	10-12 minutes
Plastic Body Fillers	18"	2' x 2'	12-18 minutes
2K Plastic Repair	18"	2' x 2'	10-15 minutes
Acrylic Enamels	18"-24"	2' x 2'	15-20 minutes
2 K Top Coats	18"-24"	2' x 2'	12-15 minutes
High Build Primers	18"	2' x 2'	10-15 minutes
Structural Adhesives	18"	2' x 2'	15-20 minutes
Polyurethane	18"-24"	2' x 2'	20-30 minutes
Synthetic Enamels	18"-24"	2' x 2'	15-25 minutes
High Solids Clear	18"-24"	2' x 2'	15-20 minutes

SPECIFICATIONS

PART NUMBER	MODEL	LENGTH	WATTS	VOLTS	AMPS	SHIPPING WEIGHT (LBS)
14-2505	TLS-1750-C	18"	1,750	120	14.5	25